

# ***GENERAL PURPOSE ENGINE***

GX120K1

**PARTS CATALOGUE**

**9**



GX120K1

---

FOREWORD INDEX

**1**

---

ENGINE GROUP

**2**

---

PART NUMBER INDEX

**3**

---

PART NAME INDEX

**4**

---



**Instruction for use of parts catalogue**

- **This parts catalogue was prepared based on the latest information available as of November 01, 2004.**
- See the parts catalogue news for any revision that is made after November 01, 2004.
- **Always specify the part number when ordering a part.**
  - Check the model, type, serial numbers, color, maker, and the size as needed before ordering a part.
  - Note that the illustrations (part drawings) can differ from the actual parts in shape. They are given just to help you to refer to the parts.
- **When modifications or additions to this parts catalogue are made, a revised edition will be issued at an appropriate time, with successively progressing revision numbers on the cover. We recommend obtaining such revisions in order to keep your parts catalogue up-to-date at all times. To check whether a parts catalogue revision has been issued, please contact your Honda distributor.**

Initial version issue date **August 01, 2001**  
**Honda Motor Co., Ltd.**

**CONTENTS**

	Page	Address No.	
• How to refer to the part information .....	2	B 2	<b>1</b>
• Part catalogue structure .....	3	B 3	
• When the parts were revised .....	4	B 4	
• Abbreviations used in the parts catalogue.....	4	B 4	
• How to check the part block and serial numbers.....	5	B 5	
• Models, parts catalogue codes and applicable serial numbers .....	6	B 6	
• Features of each type.....	13	B13	
• Fuel hose, general purpose hoses and vinyl hose.....	28	C12	
• FLAT RATE SERVICE TIME.....	29	C13	
• Illustrated index .....	34	D 2	
• ENGINE GROUP.....	39	E 1	<b>2</b>
• PART NO. INDEX.....	193	2-B 1	<b>3</b>
• PART NAME INDEX.....	198	2-C 1	<b>4</b>



How to refer to the part information

A Reference with "Illustrated index"

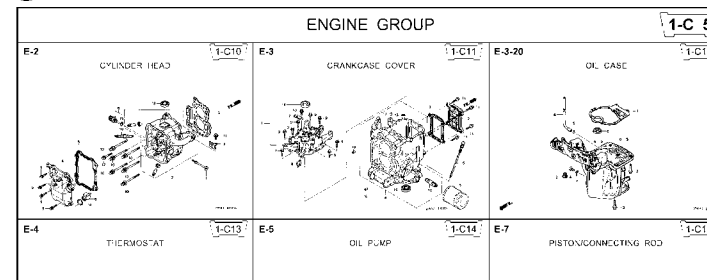

B Reference with "Part number index"

**PART NO. INDEX**

Part Number	Address	Page	Ref.	Part Number	Address	Page
06000				15212-ZW9-000	1-C14	3C
06316-ZW9-000	1-G9	88	1	15220-ZW9-003	1-C14	3C
11000				15332-ZW9-000	1-E8	55
11300-ZW9-405	1-C11	27	1	15332-ZW9-A30	1-E11	58
11300-ZW9-406	1-C11	27	1	15400-PFB-004	1-C11	27
11340-ZW9-000	1-C11	27	2	15422-ZW9-000	1-C14	3C
11342-ZW9-000	1-C11	27	3	15473-881-000	1-C14	3C
11381-ZW9-003	1-C12	28	1	15474-ZW9-000	1-C14	3C
				15611-921-000	1-C10	2E
				15655-ZW9-000	1-C11	27
				16000		
12000				16010-ZV4-005	1-D4	3E
12000-ZW9-405ZA	1-C11	27	4	16011-ZV4-005	1-D4	3E
12155-ZV4-A00	1-C13	29	1	16013-ZW9-003	1-D4	3E
12166-ZW9-000	1-C10	26	1	16016-ZW9-003	1-D4	3E
12209-GB4-681	1-C16	32	1	16016-ZW9-721	1-D4	3E
12210-ZW9-405ZA	1-C10	26	2	16023-ZW9-003	1-D4	3E
12216-ZE2-300	1-E8	55	1	16024-ZV4-650	1-D4	3E
	1-E11	58	1	16028-ZV4-650	1-D4	3E

C Reference with "Part name index"

**PART NAME INDEX**

Part name	Address	Page	Ref.
[ A ]			
ABSORBER , FUEL	1-E15	62	5
ARMATURE COMP.	1-D11	43	7
ARM COMP. , LINK JOINT	1-G6	85	18
ARM COMP. , SHIFT LINK	1-G6	85	14
ARM COMP. , TILT	1-F15	79	20
ARM , FUEL PUMP ROCKER	1-C16	32	4
ARM , REVERSE LOCK	1-F15	79	18
ARM , SHIFT LINK	1-F11	74	7
ARM , STOPPER	1-D1	33	12
ARM , THROTTLE REMOTE	1-F11	74	6
ARM , VALVE ROCKER	1-C16	32	3
[ B ]			
BAG , TOOL , 160MM	1-G5	84	10
BAND	1-G6	86	37
BAND B1 , WIRE	1-F6	69	1
BAND , CORD	1-F3	67	18
BAND , TUBE CLIP , 11MM	1-E15	63	20
BAND , TUBE CLIP , 12.5MM	1-E15	63	19

**E-2 CYLINDER HEAD**

**Address No. 1-C10**

**Block No.**

**Ref No.**

Ref. No.	Part No.	Description	Reqd. QTY						Serial No.	Parts catalogue code
			BF	BFP	BF	BFP	BF	BFP		
			9901	9901	1001	1001	1001	1001		
1	12166-ZW9-000	STOPPER, ENGINE SIDE	2	2	2	2	2	2		
2	12210-ZW9-000ZA	HEAD COMP., CYLINDER	1	1	1	1	1	1		
3	12251-ZW9-003	GASKET, CYLINDER HEAD	1	1	1	1	1	1		
4	12310-ZW9-000	COVER COMP., HEAD	1	1	1	1	1	1		
5	12312-ZW9-000	PACKING, HEAD COVER	1	1	1	1	1	1		
6	15611-921-000	CAP, OIL (NO GAUGE)	1	1	1	1	1	1		
7	16617-ZW9-000	HOLDER, CABLE	1	1	1	1	1	1	SC,SG	
	16617-ZW9-010		1	1	1	1	1	1	1001801	LHC,LHD
8	35673-ZW5-003	SENSOR ASSY., WATER	1	1	1	1	1	1		
9	90003-ZW9-000	BOLT, FLANGE, 6X22	4	4	4	4	4	4		
10	90007-ZW9-003	BOLT, FLANGE, 8X83	6	6	6	6	6	6		
11	90011-ZW9-000	BOLT, FLANGE, 6X14 (CT200)	1	1	1	1	1	1		
12	90020-ZW9-000	BOLT, FLANGE, 8X40	2	2	2	2	2	2		
13	91305-KJ9-003	OIL SEAL, 20X32X6	1	1	1	1	1	1		
14	91301-805-000	O-RING, 26X2.7	1	1	1	1	1	1		
15	91307-PK2-005	O-RING, 9.5X1.5 (HONDA KIKAKI)	1	1	1	1	1	1		
16	98059-55916	PLUG, SPARK (CR5EH-D)	2	2	2	2	2	2		
	98059-55926	PLUG, SPARK (U16FERD)	2	2	2	2	2	2		

**Page No.**

2000.09.20 E

Part catalogue structure

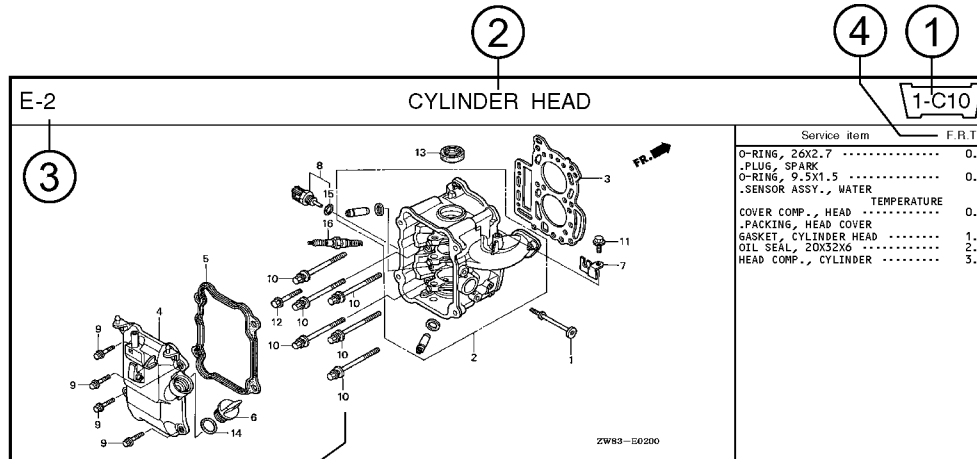

Ref. No.	Part No.	Description	Reqd. QTY						Serial No.	Parts catalogue code
			BF 9/9D1	BFP 9/9D1	BF 10D1	BFP 10D1	BF 10B1	BFP 10B1		
1	12166-ZW9-000	STOPPER, ENGINE SIDE	2	2	2	2	2	2		
2	12210-ZW9-000ZA	HEAD COMP., CYLINDER *NHS*	1	1	1	1	1	1		
3	12251-ZW9-003	GASKET, CYLINDER HEAD	1	1	1	1	1	1		
4	12310-ZW9-000	COVER COMP., HEAD	1	1	1	1	1	1		
5	12312-ZW9-000	PACKING, HEAD COVER	1	1	1	1	1	1		
6	15611-921-000	CAP, OIL (NO GAUGE)	1	1	1	1	1	1		
7	16617-ZW9-000	HOLDER, CABLE	1	1	1	1	1	1	SC,SG	
	16617-ZW9-010		1	1	1	1	1	1	1001800 LHC,LHD	

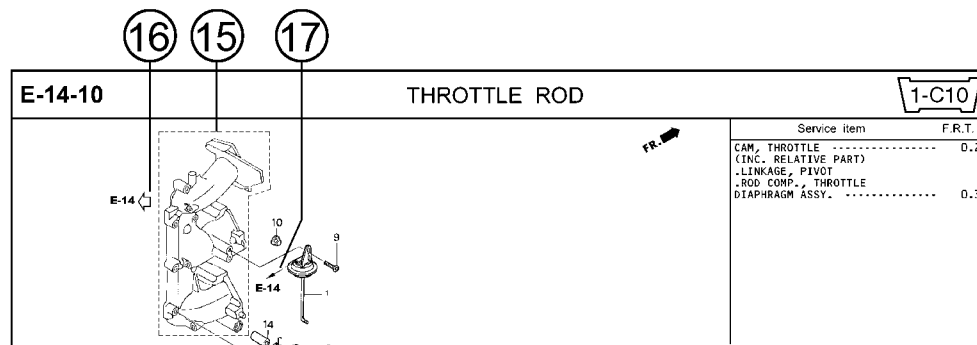

① Address number

- Address No. is provided (in place of the page No.) to help you refer to the part with the part No. or part name.

② Block title ③ Block number

④ Service item/Flat rate time

⑤ Reference number

- Title number marked with the parenthesis or parentheses indicates that it continues from the previous page.

⑥ Part number ⑦ Honda color code

⑧ Description

⑨ Assemblies

- Sections framed with broken lines in the exploded view drawings are available as complete assemblies. (Their individual parts can also be obtained.)

⑩ Color description

⑪ Note

- Notes are shown with the parentheses in the part name column.

⑫ Required quantity

- Required QTY shown in the parenthesis or parentheses indicates the optional part.
- Required QTY marked with "N" Indicates the optional part that should be selected as needed.
- Required QTY indicates the number of the part used in the block.

⑬ Serial number

⑭ Type

- When the type column is blank, it indicates that the part is applicable to all types.
- As the type of the actual unit may differ from the "parts catalogue, type" please refer to "Models, types and applicable serial numbers" for confirmation.

⑮

- Parts enclosed within a dotted line are covered in a different block.

⑯

- A hollow arrow indicates the block No. for the parts enclosed within a dotted line .

⑰

- A solid arrow indicates the block No. the part in question is connected to.

When the parts were revised

Abbreviations used in the parts catalogue

1



Be sure to check the serial number!!



Ref. No.	Part No.	Description	Reqd. QTY						Serial No.
			BF 99D1	BFP 9.9D1	BF 10D1	BFP 10D1	BF 10B1	BFP 10B1	
1	12166-ZW9-000	STOPPER, ENGINE SIDE .....	2	2	2	2	2	2	
2	12210-ZW9-000ZA	HEAD COMP., CYLINDER *NH8* .....	1	1	1	1	1	1	
3	12251-ZW9-003	GASKET, CYLINDER HEAD .....	1	1	1	1	1	1	
4	12310-ZW9-000	COVER COMP., HEAD .....	1	1	1	1	1	1	
5	12312-ZW9-000	PACKING, HEAD COVER .....	1	1	1	1	1	1	
6	15611-921-000	CAP, OIL (NO GAUGE) .....	1	1	1	1	1	1	
7	16617-ZW9-000	HOLDER, CABLE (###) .....	1	1	1	1	1	1	
	16617-ZW9-010	.....	1	1	1	1	1	1	



The number has been used from the initial model without revision. When shown at the left side, it is applicable to the models of No.1001801 and the subsequent numbers. When shown at the right side, it is applicable to the models up to No.1001800.

• The parts listed with "###" at the end of the parts name have limited supply period (parts not for sale).

• The following abbreviations are used in the parts name column.

- A ..... Ampere
- A.C. .... Alternating current
- ASSY. .... Assembly
- AT. .... Automatic transmission
- C.D.I. .... Capacitive discharge ignition
- COMP. ... Complete
- D.C. .... Direct current
- EX. .... Exhaust
- G.F.C.I ... Ground fault circuit interruptor
- HEX. .... Hexagonal
- H.S.T. .... Hydrostatic transmission
- FR. ....Front
- IN. ....Inlet
- L (100L) .Link (100 Links)
- L. ....Left
- MM .....Millimeter
- MT. ....Manual Transmission
- P.T.O. ....Power take off
- R. ....Right
- RR. ....Rear
- STD. ....Standard
- T (22T) ...Tooth (22 Teeth)
- V ..... Volt
- W .....Watt

How to check the part block and serial numbers

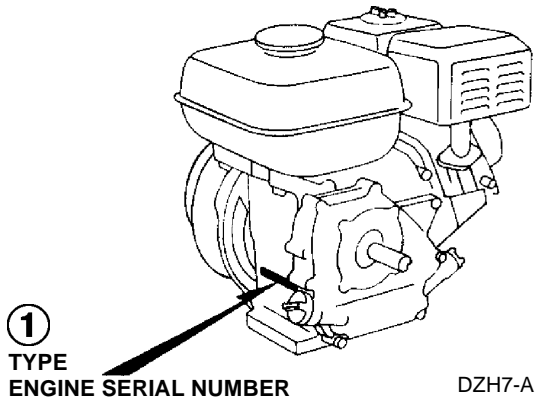
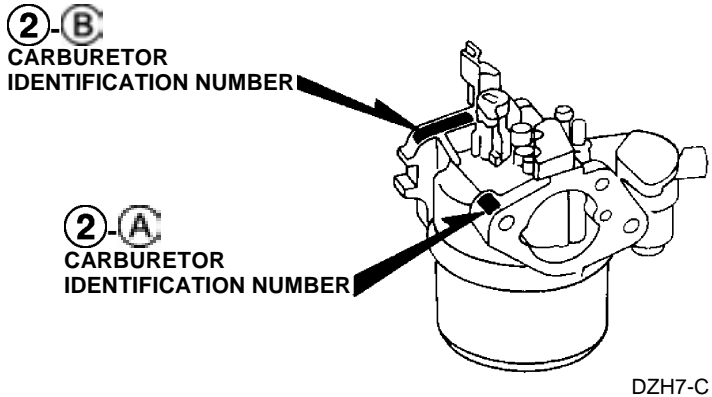
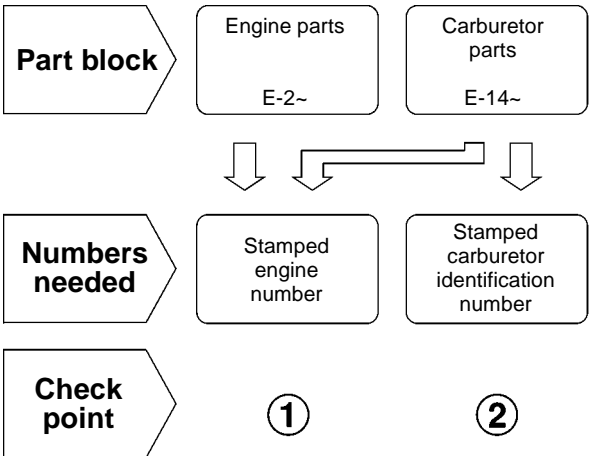



### Models, parts catalogue codes and applicable serial numbers

- Models, parts catalogue codes and applicable serial Nos. given in this parts catalogue can be identified as follows.

Model	Type	Parts catalogue type	Applicable engine serial No.	Applicable carburetor identification No.
GX120K1 (1)	AR	AR	GC01- 2000001~4299999	BE62A A BE62C A
	DKR	DKR		
	DS	DS		BE12A A / B / C BE60L A BE60C B
	EN	EN	GC01- 2000001~3553150	BE12A A / B / C BE60L A
	ET	ET		
	ETX	ETX		
	HH	HH	GC01- 2000001~4299999	BE12A A / B / C
	HHQ4	HHQ4		BE12A B / C BE60B B
	HTF2	HTF2		BE60B A / B
	HT2	HT2	BE60B B	
	HX	HX	GC01- 2000001~3553150	BE12A A / B / C BE60B B
	HXQ	HXQ		BE60A A / B
	HXU	HXU		BE12A C BE60B B
	HX2	HX2	GC01- 2000001~4299999	BE60B A / B
HX26	HX26			

Model	Type	Parts catalogue type	Applicable engine serial No.	Applicable carburetor identification No.
GX120K1 (1)	HX4	HX4	GC01- 2000001~4299999	BE12A B / C BE60B B BE62A A BE62C A
	KR	KR		
	KRA4	KRA4		BE62A A
	KRF4	KRF4		
	KRS4	KRS4		BE62C A
	KRT	KRT		BE62A A BE62C A
	KRT4	KRT4		
	KRT6	KRT6		BE62A A
	LAJ4	LAJ4		BE12A C BE60B B BE12B A / B / C BE61D B
	LD	LD		
	LDB1	LDB1	GC01- 2000001~3553150	BE12B B / C
	LDB3	LDB3	GC01- 2000001~4299999	BE12B B / C BE61D B
	LD4	LD4	GC01- 2000001~3553150	BE12B B / C
	LE	LE		BE12B A / B / C
	LEH4	LEH4	GC01- 2000001~3186277	BE12A C BE60B B
	LH	LH	GC01- 2000001~4299999	BE12A A / B / C BE60B B

Model	Type	Parts catalogue type	Applicable engine serial No.	Applicable carburetor identification No.
GX120K1 (1)	LHQ4	LHQ4	GC01- 2000001~4299999	BE12A B / C BE60B B
	LJ	LJ		BE12A A / B / C BE60L A BE60C B
	LJC	LJC		BE60L A
	LJD2	LJD2		BE60B B
	LJS	LJS		BE60C B
	LJT	LJT		GC01- 2000001~3553150
	LSJ	LSJ	GC01- 2000001~4299999	BE12A C BE60L A BE60C B
	LSJ4	LSJ4		BE12B C BE61D B
	LTA	LTA		BE12K A / B
	LTJ	LTJ		BE12A A / B / C BE60B B BE60L A BE60C B
	LTK1	LTK1		BE60L A
	LTR	LTR		BE12A C BE60L A BE60C B

Model	Type	Parts catalogue type	Applicable engine serial No.	Applicable carburetor identification No.
GX120K1 (1)	LTS	LTS	GC01- 2000001~4299999	BE60B B
	LW2	LW2	GC01- 2000001~3553150	BE12B A / B / C
	LX	LX	GC01- 2000001~4299999	BE12A A / B / C BE60B B
	LXU	LXU		BE12A C BE60B B
	LX2	LX2		BE60B A / B
	LX26	LX26		BE12A B / C BE60B B
	LX4	LX4		BE12A A / B / C BE60B B
	PH	PH		BE12B A / B / C
	PM	PM		GC01- 2000001~3553150
	PM2	PM2	GC01- 2000001~4299999	BE60B A / B
	PX	PX		BE12C A / B
	PX2	PX2		BE60B A / B
	QA	QA	GC01- 2000001~3553150	BE12C A / B
	QAA2	QAA2		BE60B A / B
	QA2	QA2	GC01- 2000001~4299999	BE60B A / B
	QA26	QA26		BE60C A / B

1

Model	Type	Parts catalogue type	Applicable engine serial No.	Applicable carburetor identification No.
GX120K1 (1)	QBU2	QBU2	GC01- 2000001~3553150	BE60B A / B
	QB26	QB26	GC01- 2000001~4299999	BE60M A BE60B B
	QD	QD		BE12B A / B / C BE61D B
	QE	QE		BE12B A / B / C BE61G A
	QEH	QEH	GC01- 2000001~3181627	BE12A A / B / C BE60B B
	QH	QH	GC01- 2000001~4299999	BE12A B / C BE60B B
	QHQ4	QHQ4		BE60B A / B
	QH2	QH2		BE60B B
	QH26	QH26		BE12A C BE60B B
	QJG2	QJG2		BE12A B / C
	QJW1	QJW1		BE12B A / B / C
	QLL	QLL		BE12A B / C
	QM	QM		BE12A B / C BE60B B
	QMA4	QMA4		BE12A B / C BE60L A
	QMA8	QMA8		
	QME4	QME4		

Model	Type	Parts catalogue type	Applicable engine serial No.	Applicable carburetor identification No.
GX120K1 (1)	QMH	QMH	GC01- 2000001~4299999	BE12A C BE60B B
	QMX2	QMX2		BE60B A / B
	QPU	QPU		BE12A A / B / C BE60B B
	QSJ	QSJ	GC01- 2000001~3553150	BE12A C BE60L A
	QT	QT	GC01- 2000001~4299999	BE12A A / B / C BE60L A
	QTC2	QTC2		BE60B A / B
	QWA4	QWA4		BE60B B
	QX	QX		BE12A A / B / C BE60B B
	QXC	QXC	GC01- 2000001~3553150	BE13A A / B BE60F B
	QXC9	QXC9		BE60F A / B
	QXG	QXG		BE12A A / B / C
	QXG2	QXG2	GC01- 2000001~4299999	BE60B A / B
	QXQ	QXQ	GC01- 2000001~3553150	BE60A A / B
	QXS	QXS	GC01- 2000001~4299999	BE12A A / B / C
	QXS2	QXS2		BE60B A / B
	QXU	QXU		BE12A C BE60B B

Model	Type	Parts catalogue type	Applicable engine serial No.	Applicable carburetor identification No.
GX120K1 (1)	QX2	QX2	GC01- 2000001~4299999	BE60B A / B
	QX26	QX26		BE60B A / B
	QX4	QX4		BE12A B / C BE60B B
	QX7	QX7		BE60B B
	RD	RD		BE12B A / B / C BE61D B
	RD4	RD4		BE12B B / C BE61D B
	RH	RH	GC01- 2000001~3553150	BE12A A / B / C
	RHC	RHC	GC01- 2000001~4299999	BE12A B / C BE60B B
	RHQ4	RHQ4		BE12A A / B / C BE60B B
	RX	RX		BE12A B / C BE60B B
	RX4	RX4		BE12A B / C BE60B B
	SAD2	SAD2	GC01- 2000001~3553150	BE60B A / B
	SAJ	SAJ	GC01- 2000001~4299999	BE12A B / C BE60L A BE60C B
	SAJ4	SAJ4		BE12A C BE60B B
	SCJ	SCJ		BE12A B / C BE60L A BE60C B

Model	Type	Parts catalogue type	Applicable engine serial No.	Applicable carburetor identification No.
GX120K1 (1)	SD	SD	GC01- 2000001~4299999	BE12B A / B / C BE61D B
	SDB1	SDB1		BE12B B / C BE61D B
	SDB3	SDB3		
	SD16	SD16		BE12B A / B / C BE61G A
	SD4	SD4		
	SE	SE		
	SG24	SG24		BE60B A / B
	SH	SH		BE12A A / B / C BE60B B
	SHQ4	SHQ4		BE12A B / C BE60B B
	SJ	SJ		BE12A A / B / C BE60L A BE60C B
	SJC	SJC		BE12A B / C BE60L A BE60C B
	SJC1	SJC1		BE12A C BE60L A BE60C B
	SJC5	SJC5		

1

Model	Type	Parts catalogue type	Applicable engine serial No.	Applicable carburetor identification No.
GX120K1 (1)	SJD2	SJD2	GC01- 2000001~4299999	BE60B B
	SKJ	SKJ		BE12A A / B / C BE60L A BE60C B
	SKR	SKR		BE60L A BE60C B
	SMA7	SMA7		BE12A B / C BE60B B
	SMJ	SMJ		BE12A A / B / C BE60B B
	SMW2	SMW2		BE60B A / B
	SM11	SM11		BE60B B
	SM12	SM12		
	SM14	SM14		
	SN	SN	GC01- 2000001~3132166	BE12A A / B / C BE60L A
	SSK1	SSK1	GC01- 2000001~4299999	BE12A B / C BE60B B
	SSK2	SSK2	GC01- 2000001~3553150	BE60B A / B
	SSK3	SSK3	GC01- 2000001~4299999	BE12A B / C BE60B B
	SSX2	SSX2		BE60B B
	SSX4	SSX4		BE12A B / C BE60B B
	STP	STP		BE12A B / C

Model	Type	Parts catalogue type	Applicable engine serial No.	Applicable carburetor identification No.
GX120K1 (1)	STS	STS	GC01- 2000001~4299999	BE13A A / B
	SWX2	SWX2		BE60B B
	SWX4	SWX4		
	SW2	SW2	GC01- 2000001~3553150	BE12B A / B / C
	SX	SX	GC01- 2000001~4299999	BE12A A / B / C BE60B B
	SXS4	SXS4		BE60B B
	SX4	SX4		BE12A B / C BE60B B
	SX7	SX7		BE60B B
	TH	TH		BE12A A / B / C BE60B B
	TX	TX		BE60B A / B
	TX2	TX2		
	TX26	TX26		
	TX4	TX4		BE12A B / C BE60B B
	UH	UH		BE12A A / B / C BE60B B
	UX	UX	BE12A C BE60B B	
	UXU	UXU		
	VA	VA	GC01- 2000001~3553150	BE12A A / B / C

Model	Type	Parts catalogue type	Applicable engine serial No.	Applicable carburetor identification No.
GX120K1 (1)	VAX4	VAX4	GC01- 2000001~4299999	BE12A B / C
	VED	VED		BE12A A / B / C BE60L A BE60C B
	VED1	VED1		BE60C B
	VED6	VED6		BE12A C BE60L A BE60B B
	VEE1	VEE1		BE12H B
	VEK	VEK		BE12A A / B / C BE60L A BE60C B
	VET	VET		BE12A A / B / C BE60B B
	VEX	VEX		BE60B B
	VEX7	VEX7		BE12A A / B / C BE60B B
	VH	VH		GC01- 2000001~3553150
	VMS4	VMS4	GC01- 2000001~4299999	BE12A C BE60B B
	VMT	VMT		BE28B A
	VPR4	VPR4		BE12A A / B / C BE60B B
	VS	VS		BE12A A / B / C BE60B B

Model	Type	Parts catalogue type	Applicable engine serial No.	Applicable carburetor identification No.
GX120K1 (1)	VSX	VSX	GC01- 2000001~4299999	BE12A A / B / C
	VSX1	VSX1		
	VS1	VS1	GC01- 2000001~3553150	
	VX	VX	GC01- 2000001~4299999	
	VXU	VXU		BE12A C BE60B B
	VX4	VX4		BE12A B / C BE60B B
	VX7	VX7		BE60B B
	WDA6	WDA6		BE12A B / C BE60L A BE60C B
	WDJ	WDJ		BE60C B
	WD12	WD12		BE12A A / B / C BE60L A BE60C B
	WJ	WJ		BE12A B / C BE60L A BE60C B
	WJP	WJP		BE12A C BE60L A BE60C B
	WJP1	WJP1		BE12A C BE60L A BE60C B

Model	Type	Parts catalogue type	Applicable engine serial No.	Applicable carburetor identification No.
GX120K1 (1)	WJ1	WJ1	GC01- 2000001~4299999	BE60K A BE60C B
	WKD6	WKD6		BE60C B
	WKT2	WKT2		BE60C A / B
	WKT4	WKT4		BE60C B
	WKT6	WKT6		
	WMA3	WMA3		BE12B B / C BE61D B
	WME2	WME2		BE60C A / B
	WME4	WME4		BE12B C BE61D B
	WM1	WM1		BE61F A BE61D B
GX120K1 (2)	H1	H1	GC01- 2000001~4299999	BE12B A / B / C BE13A A / B BE12A A / B / C BE12C A / B
	L1	L1		
	Q1	Q1		
	R1	R1		
	S1	S1		
	U1	U1	GC01- 2000001~3553150	BE12B A / B BE13A A BE12A A / B BE12C A

Model	Type	Parts catalogue type	Applicable engine serial No.	Applicable carburetor identification No.
GX120K1 (2)	V1	V1	GC01- 2000001~3553150	BE12B A / B / C BE13A A / B
	W1	W1	GC01- 2000001~4299999	BE12A A / B / C BE12C A / B
GX120K1 (3) (Indonesia- KD)	QIH1	QIH1	GC01- 9100001~9999999	BE60L A
	UIH	UIH		BE12A A / B / C BE60L A
	WIH1	WIH1		BE60L A
GX120K1 (4) (Venezuela- KD)	THVZ	THVZ	GC01- 9500001~9999999	BE12A A / B / C

\* Of carburetor identification numbers, only the portions underlined in the example below are used for registration.

BE 62A A KC †  
 (A) (B)

Features of each type

- See the following table for the features of each type.

Model Type		GX120K1													
		Standard equipment (1)													
Specifications		AR	DKR	DS	EN	ET	ETX	HH	HHQ4	HTF2	HT2	HX	HXQ	HXU	HX2
Crankshaft	18mm Ø Straight														
	19mm Ø Straight														
	20mm Ø Spline	●	●	●											
	21mm Ø Spline							●	●	●	●	●	●	●	●
	19.8mm Ø Tapered														
	1/5" Tapered				●	●	●								
	3/4" Thread														
	5/8" Thread														
	M14 Stepped thread														
	M16 Stepped thread														
	1/2" Stepped thread														
Reduction	1/2 Reduction	●	●	●											
	1/2 Reduction (With clutch)														
	1/6 Reduction							●	●	●	●	●	●	●	●
Fuel tank				●				●	●	●	●	●	●	●	●
Oil alert							●			●			●	●	●
Lamp coil															



Specifications		Model	GX120K1												
		Type	Standard equipment (1)												
			HX26	HX4	KR	KRA4	KRF4	KRS4	KRT	KRT4	KRT6	LAJ4	LD	LDB1	LDB3
Crankshaft	18mm Ø Straight														
	19mm Ø Straight														
	20mm Ø Spline			●	●	●	●	●	●	●	●	●	●	●	●
	21mm Ø Spline	●	●												
	19.8mm Ø Tapered														
	1/5" Tapered														
	3/4" Thread														
	5/8" Thread														
	M14 Stepped thread														
	M16 Stepped thread														
	1/2" Stepped thread														
Reduction	1/2 Reduction			●	●	●	●	●	●	●	●	●	●	●	●
	1/2 Reduction (With clutch)														
	1/6 Reduction	●	●												
Fuel tank	●	●									●	●	●	●	●
Oil alert	●	●													
Lamp coil											●				

Specifications		Model	GX120K1												
		Type	Standard equipment (1)												
			LE	LEH4	LH	LHQ4	LJ	LJC	LJD2	LJS	LJT	LSJ	LSJ4	LTA	LTJ
Crankshaft	18mm Ø Straight														
	19mm Ø Straight														
	20mm Ø Spline	●	●	●	●	●	●	●	●	●	●	●	●	●	●
	21mm Ø Spline														
	19.8mm Ø Tapered														
	1/5" Tapered														
	3/4" Thread														
	5/8" Thread														
	M14 Stepped thread														
	M16 Stepped thread														
	1/2" Stepped thread														
Reduction	1/2 Reduction	●	●	●	●	●	●	●	●	●	●	●	●	●	●
	1/2 Reduction (With clutch)														
	1/6 Reduction														
Fuel tank	●	●	●	●	●	●	●	●	●	●	●	●	●	●	●
Oil alert							●						●		
Lamp coil									●						

Specifications		Model	GX120K1												
		Type	Standard equipment (1)												
		LTR	LTS	LW2	LX	LXU	LX2	LX26	LX4	PH	PM	PM2	PX	PX2	QA
Crankshaft	18mm Ø Straight														
	19mm Ø Straight														●
	20mm Ø Spline	●	●	●	●	●	●	●	●						
	21mm Ø Spline														
	19.8mm Ø Tapered														
	1/5" Tapered														
	3/4" Thread									●	●	●	●	●	
	5/8" Thread														
	M14 Stepped thread														
	M16 Stepped thread														
	1/2" Stepped thread														
Reduction	1/2 Reduction	●	●	●	●	●	●	●	●						
	1/2 Reduction (With clutch)														
	1/6 Reduction														
Fuel tank	●	●	●	●	●	●	●	●	●	●	●	●	●	●	●
Oil alert				●	●	●	●	●					●	●	
Lamp coil			●												

Specifications		Model	GX120K1													
		Type	Standard equipment (1)													
			QAA2	QA2	QA26	QBU2	QB26	QD	QE	QEH	QH	QHQ4	QH2	QH26	QJG2	QJW1
Crankshaft	18mm Ø Straight															
	19mm Ø Straight		●	●	●	●	●	●	●	●	●	●	●	●	●	●
	20mm Ø Spline															
	21mm Ø Spline															
	19.8mm Ø Tapered															
	1/5" Tapered															
	3/4" Thread															
	5/8" Thread															
	M14 Stepped thread															
	M16 Stepped thread															
	1/2" Stepped thread															
Reduction	1/2 Reduction															
	1/2 Reduction (With clutch)															
	1/6 Reduction															
Fuel tank			●	●	●	●		●	●	●	●	●	●	●	●	●
Oil alert																●
Lamp coil							●								●	

1

Specifications		Model	GX120K1												
		Type	Standard equipment (1)												
		QLL	QM	QMA4	QMA8	QME4	QMH	QMX2	QPU	QSJ	QT	QTC2	QWA4	QX	QXC
Crankshaft	18mm Ø Straight														
	19mm Ø Straight	●	●	●	●	●	●	●	●	●	●	●	●	●	●
	20mm Ø Spline														
	21mm Ø Spline														
	19.8mm Ø Tapered														
	1/5" Tapered														
	3/4" Thread														
	5/8" Thread														
	M14 Stepped thread														
	M16 Stepped thread														
	1/2" Stepped thread														
Reduction	1/2 Reduction														
	1/2 Reduction (With clutch)														
	1/6 Reduction														
Fuel tank		●	●	●	●	●	●	●	●	●	●	●	●	●	●
Oil alert		●			●		●	●				●	●	●	●
Lamp coil															

Specifications		Model	GX120K1												
		Type	Standard equipment (1)												
			QXC9	QXG	QXG2	QXQ	QXS	QXS2	QXU	QX2	QX26	QX4	QX7	RD	RD4
Crankshaft	18mm Ø Straight												●	●	●
	19mm Ø Straight	●	●	●	●	●	●	●	●	●	●	●			
	20mm Ø Spline														
	21mm Ø Spline														
	19.8mm Ø Tapered														
	1/5" Tapered														
	3/4" Thread														
	5/8" Thread														
	M14 Stepped thread														
	M16 Stepped thread														
	1/2" Stepped thread														
Reduction	1/2 Reduction														
	1/2 Reduction (With clutch)												●	●	●
	1/6 Reduction														
Fuel tank		●	●	●	●	●	●	●	●	●	●	●	●	●	●
Oil alert		●	●			●	●	●	●	●	●	●			
Lamp coil						●	●								

1

Specifications		Model	GX120K1												
		Type	Standard equipment (1)												
		RHC	RHQ4	RX	RX4	SAD2	SAJ	SAJ4	SCJ	SD	SDB1	SDB3	SD16	SD4	SE
Crankshaft	18mm Ø Straight	●	●	●	●	●	●	●	●	●	●	●	●	●	●
	19mm Ø Straight														
	20mm Ø Spline														
	21mm Ø Spline														
	19.8mm Ø Tapered														
	1/5" Tapered														
	3/4" Thread														
	5/8" Thread														
	M14 Stepped thread														
	M16 Stepped thread														
	1/2" Stepped thread														
Reduction	1/2 Reduction														
	1/2 Reduction (With clutch)	●	●	●	●										
	1/6 Reduction														
Fuel tank			●	●	●	●	●	●	●	●	●	●	●	●	●
Oil alert				●	●										
Lamp coil		●													

Specifications		GX120K1													
		Standard equipment (1)													
		SG24	SH	SHQ4	SJ	SJC	SJC1	SJC5	SJD2	SKJ	SKR	SMA7	SMJ	SMW2	SM11
Crankshaft	18mm Ø Straight	●	●	●	●	●	●	●	●	●	●	●	●	●	
	19mm Ø Straight														
	20mm Ø Spline														
	21mm Ø Spline														
	19.8mm Ø Tapered														
	1/5" Tapered														
	3/4" Thread														
	5/8" Thread														
	M14 Stepped thread														
	M16 Stepped thread														
	1/2" Stepped thread														
Reduction	1/2 Reduction														
	1/2 Reduction (With clutch)														
	1/6 Reduction														
Fuel tank	●	●	●	●	●	●	●	●	●	●	●	●	●	●	
Oil alert	●					●	●				●	●	●		
Lamp coil									●						



Specifications		Model	GX120K1												
		Type	Standard equipment (1)												
			SM12	SM14	SN	SSK1	SSK2	SSK3	SSX2	SSX4	STP	STS	SWX2	SWX4	SW2
Crankshaft	18mm Ø Straight	●	●	●	●	●	●	●	●	●	●	●	●	●	●
	19mm Ø Straight														
	20mm Ø Spline														
	21mm Ø Spline														
	19.8mm Ø Tapered														
	1/5" Tapered														
	3/4" Thread														
	5/8" Thread														
	M14 Stepped thread														
	M16 Stepped thread														
	1/2" Stepped thread														
Reduction	1/2 Reduction														
	1/2 Reduction (With clutch)														
	1/6 Reduction														
Fuel tank	●	●	●	●	●	●	●	●	●	●	●	●	●	●	
Oil alert	●	●					●	●			●	●		●	
Lamp coil															

Specifications		GX120K1													
		Standard equipment (1)													
		SXS4	SX4	SX7	TH	TX	TX2	TX26	TX4	UH	UX	UXU	VA	VAX4	VED
Crankshaft	18mm Ø Straight	●	●	●											
	19mm Ø Straight														
	20mm Ø Spline														
	21mm Ø Spline														
	19.8mm Ø Tapered											●	●		
	1/5" Tapered													●	
	3/4" Thread														
	5/8" Thread				●	●	●	●	●						
	M14 Stepped thread														
	M16 Stepped thread														
	1/2" Stepped thread									●	●	●			
Reduction	1/2 Reduction														
	1/2 Reduction (With clutch)														
	1/6 Reduction														
Fuel tank	●	●	●	●	●	●	●	●	●	●	●	●	●	●	
Oil alert	●	●	●		●	●	●	●		●	●	●	●	●	
Lamp coil															

Specifications		Model	GX120K1													
		Type	Standard equipment (1)													
			VED1	VED6	VEE1	VEK	VET	VEX	VEX7	VH	VMS4	VMT	VPR4	VS	VSX	VSX1
Crankshaft	18mm Ø Straight															
	19mm Ø Straight															
	20mm Ø Spline															
	21mm Ø Spline															
	19.8mm Ø Tapered							•	•	•	•		•	•	•	•
	1/5" Tapered	•	•	•	•	•						•				
	3/4" Thread															
	5/8" Thread															
	M14 Stepped thread															
	M16 Stepped thread															
	1/2" Stepped thread															
Reduction	1/2 Reduction															
	1/2 Reduction (With clutch)															
	1/6 Reduction															
Fuel tank		•	•	•	•	•	•	•	•	•	•	•		•	•	•
Oil alert		•	•	•				•	•		•	•	•		•	•
Lamp coil																

Specifications		Model	GX120K1													
		Type	Standard equipment (1)													
		VS1	VX	VXU	VX4	VX7	WDA6	WDJ	WD12	WJ	WJP	WJP1	WJ1	WKD6	WKT2	
Crankshaft	18mm Ø Straight															
	19mm Ø Straight															
	20mm Ø Spline															
	21mm Ø Spline															
	19.8mm Ø Tapered	●	●	●	●	●										
	1/5" Tapered															
	3/4" Thread															
	5/8" Thread															
	M14 Stepped thread						●	●	●	●				●	●	●
	M16 Stepped thread										●	●				
	1/2" Stepped thread															
Reduction	1/2 Reduction															
	1/2 Reduction (With clutch)															
	1/6 Reduction															
Fuel tank		●	●	●	●	●	●	●	●	●	●	●	●	●	●	
Oil alert			●	●	●	●								●	●	
Lamp coil																

Specifications		Model	GX120K1													
		Type	Standard equipment (1)						Selective equipment (2)							
			WKT4	WKT6	WMA3	WME2	WME4	WM1	H1	L1	Q1	R1	S1	U1	V1	W1
Crankshaft	18mm Ø Straight										●	●				
	19mm Ø Straight									●						
	20mm Ø Spline								●							
	21mm Ø Spline							●								
	19.8mm Ø Tapered													●		
	1/5" Tapered															
	3/4" Thread															
	5/8" Thread															
	M14 Stepped thread	●	●	●			●									●
	M16 Stepped thread				●	●										
	1/2" Stepped thread													●		
Reduction	1/2 Reduction								●							
	1/2 Reduction (With clutch)										●					
	1/6 Reduction							●								
Fuel tank	●	●	●	●	●	●	(●)	(●)	(●)	(●)	(●)	(●)	(●)	(●)	(●)	
Oil alert	●	●		●			(●)	(●)	(●)	(●)	(●)	(●)	(●)	(●)	(●)	
Lamp coil							(●)	(●)	(●)	(●)	(●)	(●)	(●)	(●)	(●)	

Specifications		Model	GX120K1			
		Type	Indonesia-KD (3)			Venezuela-KD (4)
			QIH1	UIH	WIH1	THVZ
Crankshaft	18mm Ø Straight					
	19mm Ø Straight	●				
	20mm Ø Spline					
	21mm Ø Spline					
	19.8mm Ø Tapered					
	1/5" Tapered					
	3/4" Thread					
	5/8" Thread				●	
	M14 Stepped thread					
	M16 Stepped thread			●		
	1/2" Stepped thread		●			
Reduction	1/2 Reduction					
	1/2 Reduction (With clutch)					
	1/6 Reduction					
Fuel tank		●	●	●	●	
Oil alert						
Lamp coil						

## Fuel hose, general purpose hoses and vinyl hose

- The standard part fuel hose, general purpose hose and vinyl hose may be substituted by the coiled bulk part.
- When ordering the standard part fuel hose, general purpose hose and vinyl hose use the bulk part number written in the parts catalog in brackets ( ) underneath the part name.
- When exchanging the hose, cut and use at the specified length as mentioned in the part name.  
(For the method of cutting the bulk part, and method of filling out orders etc., please refer to the instructions issued with the bulk part.)

### Bulk part number of fuel hose, general purpose hose and vinyl hose.

Example: 9 5 0 0 1 - 7 5 0 0 1 - 5 0 M

**Bulk part number:**  
Refers to the bulk part.

**Marking code (fuel hose and general purpose hose)**

**Change code (Vinyl hose)**

Indicates number mark or change sequence, however, the code for the bulk part must be strictly 0 (zero).

**Types of code:**

- |             |  |                |  |              |   |
|-------------|--|----------------|--|--------------|---|
| • Fuel hose | 2: Red outside braid<br>(3 mm inside dia. only)        | • General hose | 1: Ash gray<br>2: Ash gray<br>3: Black<br>5: Black | • Vinyl hose | 1: Clear<br>2: Black<br>3: Light red<br>6: Light red<br>7: Pale black |
|             | 5: Black inside braid                                  |                |  |              |   |
|             | 3: Red (3 mm inside dia. only)                         |                |  |              |   |
|             | 4: Ash gray with red stripe<br>(3 mm inside dia. only) |                |  |              |   |
|             | 6: Black   |                |  |              |   |

**Lengths:**

- 001: 1 m (standard)  
003: 3 m  
008: 8 m } Application or specification of some parts is not settled.

**I.D code: (fuel hose and general purpose hose)**

- |            |                    |                    |                             |                             |
|------------|--------------------|--------------------|-----------------------------|-----------------------------|
| 30: 3.0 mm | 50: 5.0 mm         | 70: 7.0 mm         | 11: 11 mm                   | 12: 12 (outside dia. 17) mm |
| 35: 3.5 mm | 55: 5.3 mm, 5.5 mm | 75: 7.3 mm, 7.5 mm | 91: 12 (outside dia. 15) mm | 14: 14 mm                   |
| 45: 4.5 mm | 65: 6.5 mm         | 80: 8.0 mm         | 92: 12 (outside dia. 16) mm | 17: 17 mm                   |

**ID./OD. code: (vinyl hose)**

- |                         |                          |                           |                           |                           |
|-------------------------|--------------------------|---------------------------|---------------------------|---------------------------|
| 01: ID. 2.9, OD. 6.8 mm | 12: ID. 5.0, OD. 7.0 mm  | 21: ID. 8.0, OD. 9.0 mm   | 37: ID. 11.0, OD. 15.0 mm | 50: ID. 16.0, OD. 19.0 mm |
| 03: ID. 3.0, OD. 6.0 mm | 10: ID. 5.0, OD. 8.0 mm  | 23: ID. 8.0, OD. 12.0 mm  | 38: ID. 12.0, OD. 13.0 mm | 55: ID. 17.5, OD. 20.5 mm |
| 05: ID. 3.5, OD. 6.5 mm | 11: ID. 5.0, OD. 9.0 mm  | 25: ID. 9.0, OD. 11.0 mm  | 39: ID. 12.0, OD. 14.0 mm | 60: ID. 22.0, OD. 27.0 mm |
| 07: ID. 4.0, OD. 7.0 mm | 14: ID. 6.0, OD. 9.0 mm  | 27: ID. 9.0, OD. 13.0 mm  | 40: ID. 12.0, OD. 16.0 mm |                           |
| 08: ID. 4.5, OD. 6.5 mm | 17: ID. 7.0, OD. 9.0 mm  | 33: ID. 10.0, OD. 14.0 mm | 43: ID. 13.0, OD. 15.0 mm |                           |
| 09: ID. 4.5, OD. 8.0 mm | 19: ID. 7.0, OD. 11.0 mm | 36: ID. 11.0, OD. 13.0 mm | 45: ID. 14.0, OD. 18.0 mm |                           |

**Hose type:**

- 1: Fuel hose  
3: Vinyl hose  
5: General hose

⊙ **CAUTION: It is DANGEROUS to confuse the fuel hose with the general purpose hose or vinyl hose.**

Never use a general purpose hose or vinyl hose in place of a fuel hose or vice versa. Always use the correct bulk part in the parts catalogue, according to the service manual or the instructions issued with the bulk part.

## FLAT RATE SERVICE TIME

Flat rate service time (FRT) means the standard time required to service a product, which is listed in this manual to help the dealers control the actual working process and calculate the service charge by using it as a guide.

### FRT setting system

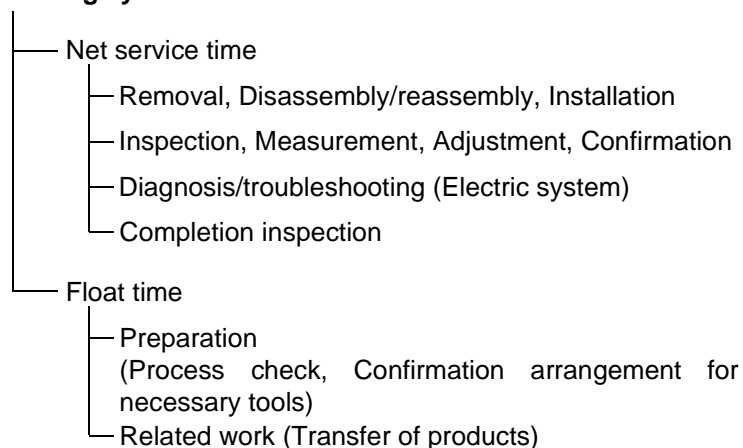

\* Float time is set by multiplying the net service time by a given coefficient.

### Editorial style

The service items shown in the text are listed with the exchange work time for the repair sales parts as the subject. Other representative service items not using repair parts (removal/installation, adjustment, inspection/measuring, and other work) are listed collectively in the list in the preface, classified according to the work.

### FRT setting standard

- Decimal system (in unit of 0.1) is adopted to set FRT as it is convenient to calculate the wage.  
Example: (0.1) → 6 minutes, (0.2) → 12 minutes  
[Labor cost per hour] x [FRT] = [Wage]
- FRT is set with a hand tool.
- Service items and FRT can be subject to change depending on development of tools and service equipment and improvement in service procedure.



**Work procedure**

- As the work procedure is set with the work time according to the method in the separate Service Manual, refer to this Manual as required.
- Work methods permitting servicing in the shortest time still permitting assurance of safe work and product warranty are used for the setting of service items not listed in the Service Manual.
- Work basically is to be performed by one person, and when two or more people are required, setting is done as the total time for the number of people.
- The set value for the technological level of the workers uses a person with three years of experience in the repair of Honda products as the standard.
- Special tools and service equipment used to set FRT are those specified or recommended in Service Manual.

**Service item whose FRT is not presented**

- Accessories and service parts that are not listed to use in this manual.
  - Locations with little aging deterioration or breakage during normal use.
  - Service work that can be finished by one touch.
  - Service work that is seldom done (i.e. extremely small causes of trouble and service frequency).
  - Products and parts whose location for installation differs according to its status of use and application.
- \* When FRT is not presented, please calculate wages based on appropriate actual work time.

**Operation not included of FRT**

- Oil and coolant water draining, Waiting time for warming up operation and etc..
- Additional operation that involves removal/installation of standard exterior equipment.
- Indirect time spent for service by visiting the customer, trade-in, and delivery.
- Indirect time required for ordering and delivery of parts.
- Cost for grease, adhesive agent, etc. used for service work.

**Explanation of FRT by using an example  
(The example may differ from the actual presented items)**

Ref. No.	L.O.N.	(Relative ref. Number) Description	F.R.T.
①	1111L1	(1, 3, 4, 7) VALVE, INTAKE ..... 4.1	②
③	1111L1A	• NOTE: OHV type • Includes: Engine removal and installation One head (intake all) add ..... 1.4	⑦ ⑤

- ① Reference No. of the illustration of part that shows location of the replacement work.
- ② FRT is an abbreviation of Flat Rate Time indicating the standard service time required for the replacement.
- ③ LON is an abbreviation of Labor Operation Number, and it is a classification of the service items by the work unit code.

The same operation code is used regardless of the models.

Standard operation is indicated with 6 digits code, and additional operation is indicated with 7 digits code.

- ④ Indicating the intake valve replacement and FRT4.1.
- ⑤ Indicating FRT1.4 that will be added when additional operation (whole intake side of one cylinder head) is done in association with intake valve replacement.

- ⑥ Indicating work condition or application condition of the service item.
- ⑦ Indicating work contents that are included in the service item.
- ⑧ Indicating a reference No. whose operation and time are the same as FRT4.1 for the intake valve.

(The application range is limited to the service items without an LON setting within a same block.)

**How to refer to the service item by using the sample  
(intake valve replacement)**

Open to the page of the block where the intake valve's spare part illustration is shown.

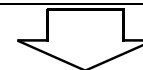

Look for the intake valve illustration, and refer to the service item and FRT that agree with the reference No.

Indication mark for the listing of service items that continues to the following page

Ref. No.	L.O.N.	(Relative ref. Number) Description	F.R.T.
2	1111L1	VALVE, INTAKE .....	4.1
	.	.	.
	.	.	.

+  
Mark indicated at the last line.

Indication of the block with no setting of FRT

Ref. No.	L.O.N.	(Relative ref. Number) Description	F.R.T.
NO INFORMATION .....			

• LON code system

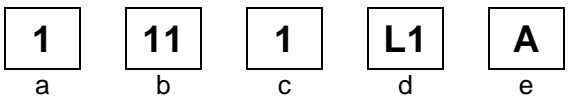

- a) Category code..... Engine
- b) Location/function code ..... Engine upper
- c) Operation code..... Replace
- d) Operation sequence number (Unit code can be shown with alphabet)  
..... Intake valve  
(No regular rule of code)
- e) Additional code ..... One head (intake all)  
(No regular rule of code)

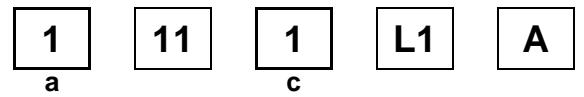

a) Category codes and classification

Code	Category
1	Engine
2	Power drive
3	Fuel & Exhaust
4	Frame & Body
5	Steering
6	Electrical
7	Axle & Brake
8	Control system
9	-
0	Attachments

c) Operation codes and classification

Code	Operation category
1	Replace, Removal/Installation, Change
2	Overhaul
3	Adjust, Rotation
4	(Paint-related work: Top-coat)
5	Test, Inspect/diagnose, Measurement
6	(Overhaul-related work: Rebore)
7	(Overhaul-related work: Reseal)
8	(Resurface)
9	(Paint-related work: Refinish)
0	Repair, Cleaning, Air bleeding

Major service items without using spare parts

(1) Removal/Installation, (2) Adjustment, (3) Inspection/Measurement, (4) Overhaul, (5) Other work

E: Engine, T: Transmission, D: Drive system, B: Body and related parts

### (2) Adjustment

	LON	DESCRIPTION	FRT
E	1113A1	<b>VALVE CLEARANCE-ADJUSTMENT</b> NOTE: For 1 product	0.3
	1163A0	<b>CONTROL, THROTTLE/GOVERNOR-ADJUSTMENT</b>	0.2
	3113A2	<b>CARBURETOR IDLE-ADJUSTMENT</b>	0.2

### (3) Inspection, Measurement, Cleaning

	LON	DESCRIPTION	FRT
E	1105A0	<b>ENGINE OIL-INSPECTION</b>	0.1
	3120A0	<b>AIR CLEANER-CLEANING</b> INCLUDES: Air cleaner-inspection	0.2
	3130A0	<b>SPARK ARRESTER-CLEANING</b>	0.2
	6140A0	<b>SPARK PLUG-CLEANING</b> INCLUDES: Spark plug gap-adjustment NOTE: For 1 product	0.2
	6145A0	<b>SPARK-TEST</b> NOTE: All cylinders	0.2

### (4) Overhaul

Work condition: The required Measurements, inspections, adjustments, and cleaning/washing of each part are performed, including the main body removal/installation work and the replacement of defective parts.

	LON	DESCRIPTION	FRT
E	3112A0	<b>CARBURETOR-OVERHAUL</b> INCLUDES: All necessary adjustment	0.6

### (5) Other work

	LON	DESCRIPTION	FRT
E	1101E1	<b>ENGINE OIL-CHANGE</b> INCLUDES: Engine oil-inspection	0.1

# ENGINE GROUP

**D 2**

**E-2**

**CYLINDER HEAD**

**E 1**

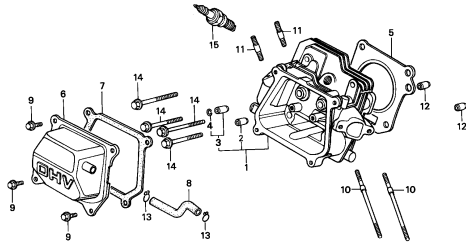

Z1170-E0200



**E-3**

**CYLINDER BARREL**

**E10**

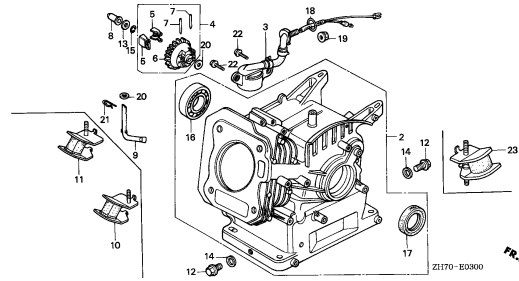

Z1170-E0300



**E-6**

**CRANKCASE COVER**

**E14**

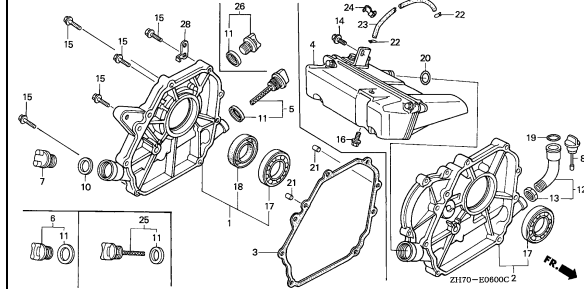

Z1170-E0600C 2



**E-7**

**CRANKSHAFT**

**F 4**

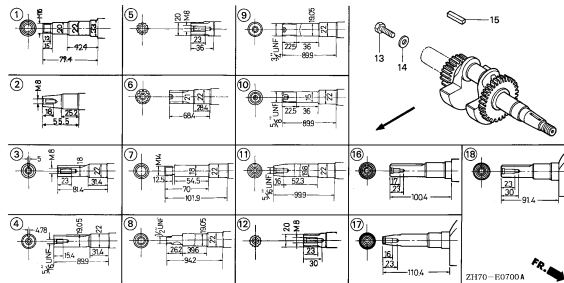

Z1170-E0700A



**E-8**

**PISTON/CONNECTING ROD**

**F 6**

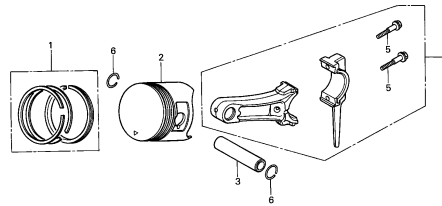

Z1170-E0800



**E-9**

**CAMSHAFT**

**G 2**

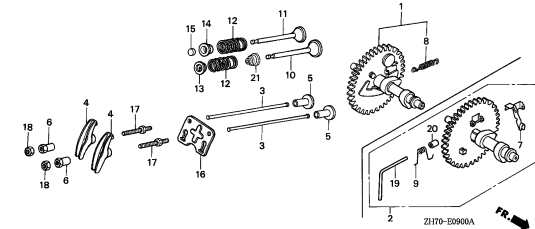

Z1170-E0900A



**E-11**

**RECOIL STARTER(1)**

**G 7**

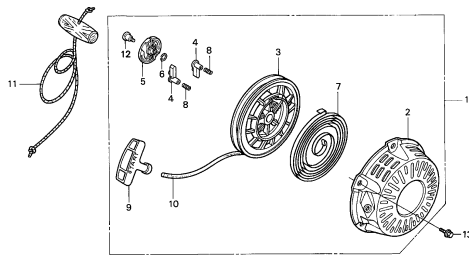

Z1170-E1100



**E-11-1**

**RECOIL STARTER(2)**

**G15**

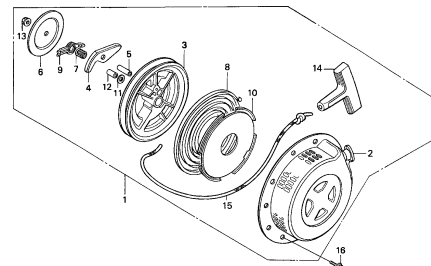

Z1170-E1101A



**E-12**

**FAN COVER**

**G16**

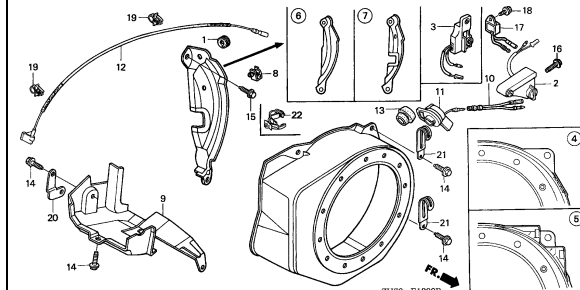

Z1170-E1200B



**2**

# ENGINE GROUP

D 3

E-14

CARBURETOR(1)

H 6

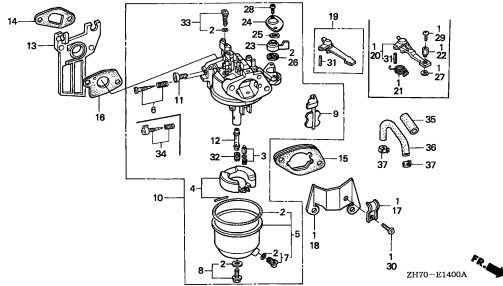

E-14-1

CARBURETOR(2)

H11

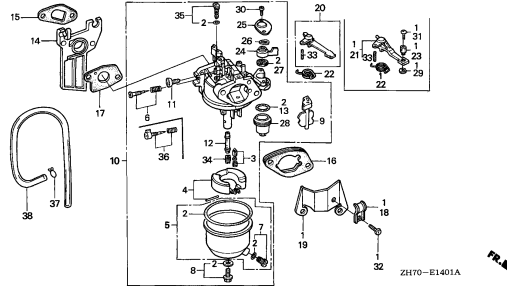

E-15

AIR CLEANER(1)

I11

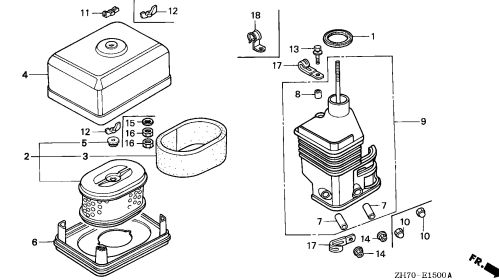

E-15-1

AIR CLEANER(2)

J 2

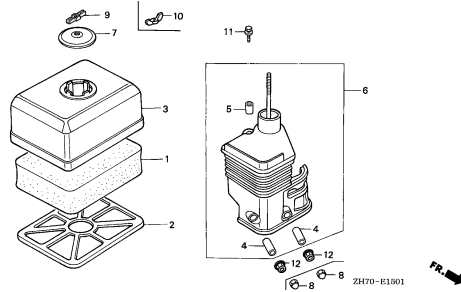

E-15-2

AIR CLEANER(3)

J 4

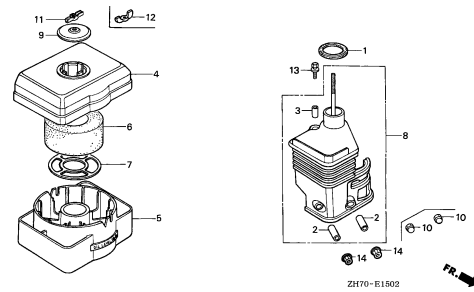

E-15-3

AIR CLEANER(4)

J 6

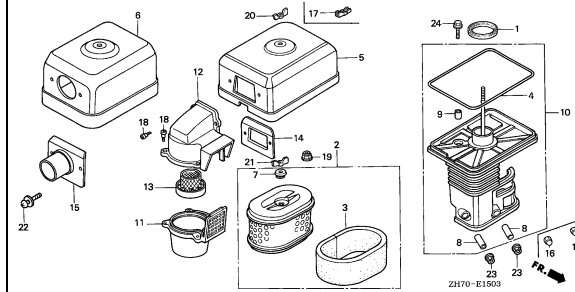

E-15-4

AIR CLEANER(5)

J 8

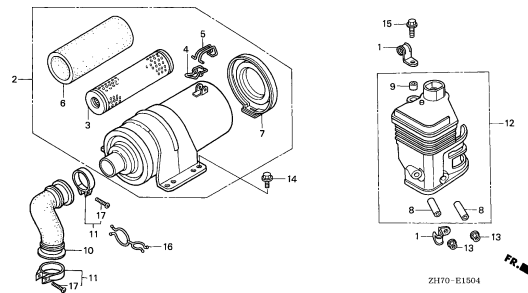

E-15-5

AIR CLEANER(6)

J 9

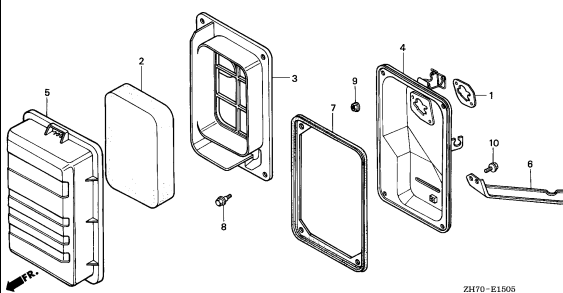

E-16

MUFFLER(1)

J10

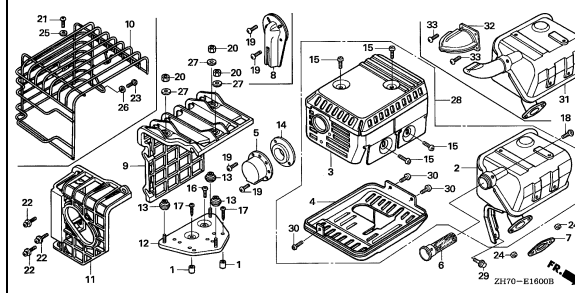

2

# ENGINE GROUP

**D 4**

**E-16-1**

MUFFLER(2)

**J16**

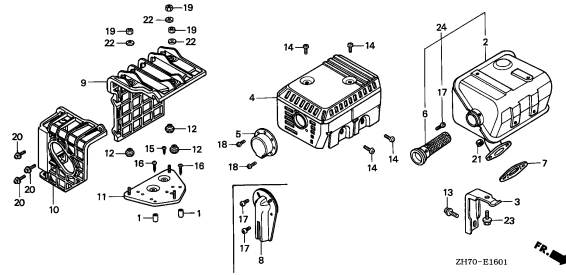

**E-16-2**

MUFFLER(3)

**K 2**

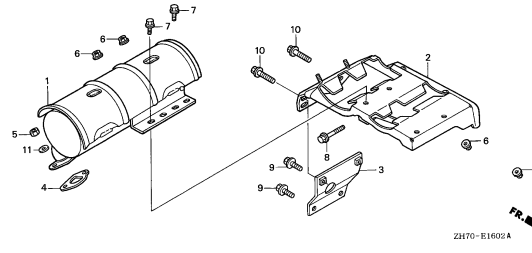

**E-16-3**

MUFFLER(4)

**K 3**

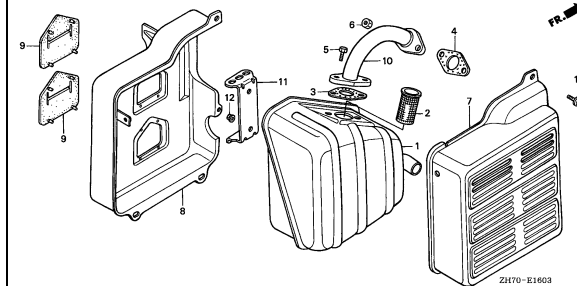

**E-17**

FUEL TANK(1)

**K 4**

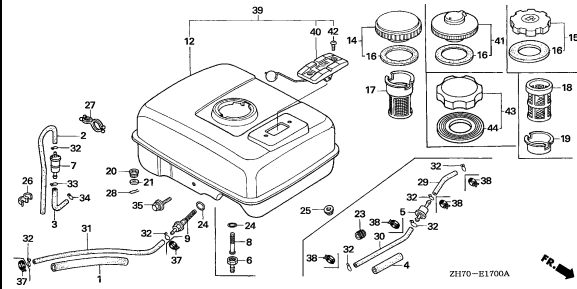

**E-17-1**

FUEL TANK(2)

**K12**

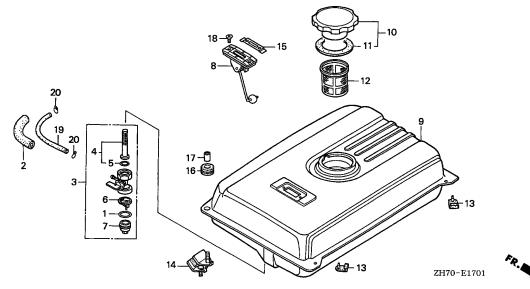

**E-17-2**

FUEL TANK(3)

**K13**

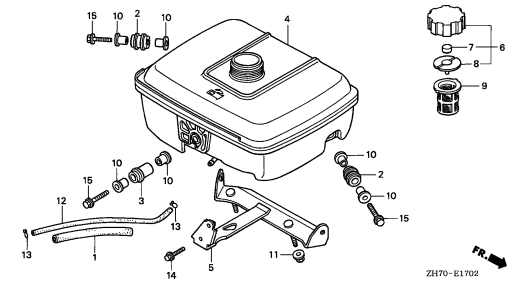

**E-17-3**

FUEL TANK(4)

**K14**

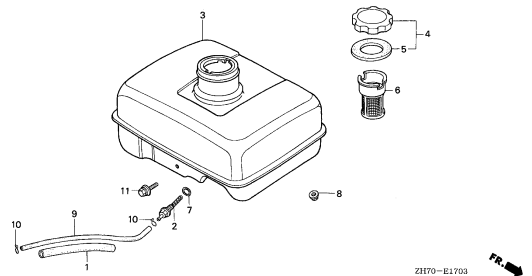

**E-19**

FLYWHEEL

**K15**

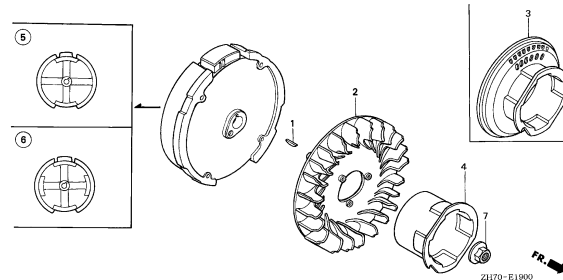

**E-20**

IGNITION COIL

**L 2**

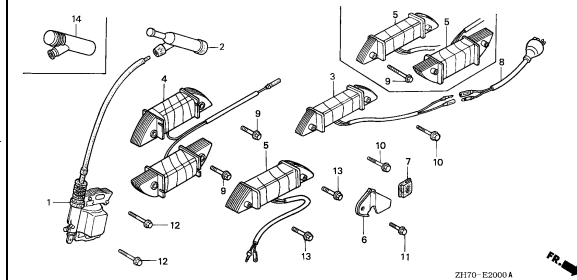

**2**

# ENGINE GROUP

**D 5**

**E-22**

CONTROL(1)

**L 5**

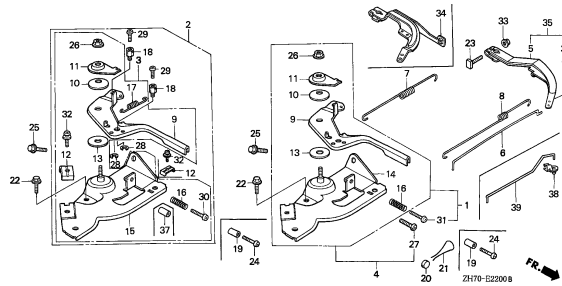

**E-22-1**

CONTROL(2)

**L16**

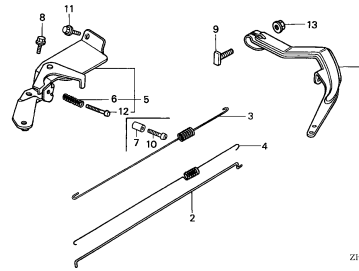

**E-22-2**

CONTROL(3)

**M 2**

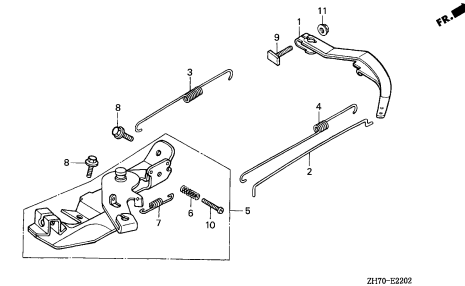

**E-26**

REDUCTION(1/2)

**M 3**

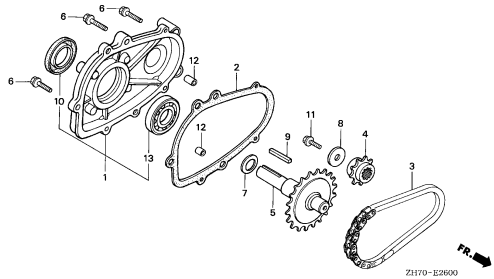

**E-26-1**

REDUCTION(1/2)

**M 5**

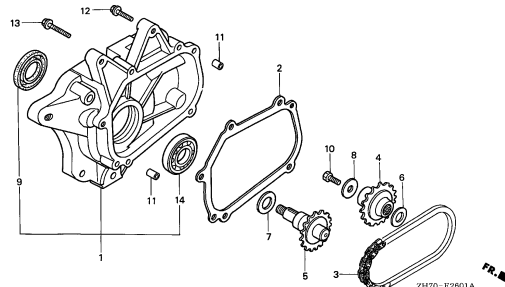

**E-26-2**

REDUCTION(1/2)(WITH CLUTCH)

**M 6**

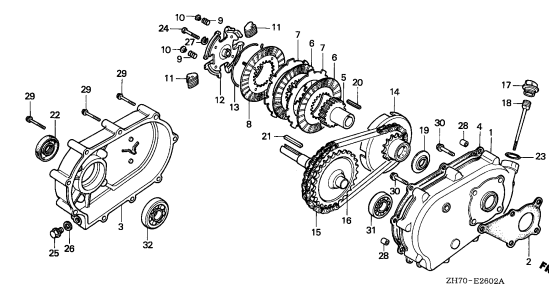

**E-26-3**

REDUCTION(1/6)

**M 8**

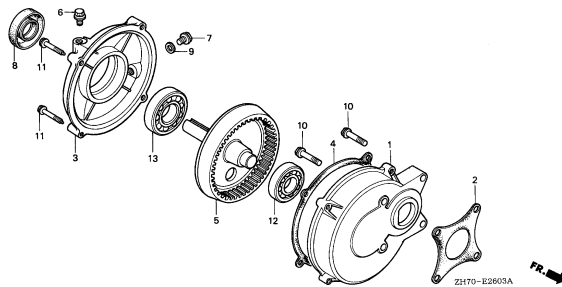

**E-28**

LABEL

**M 9**

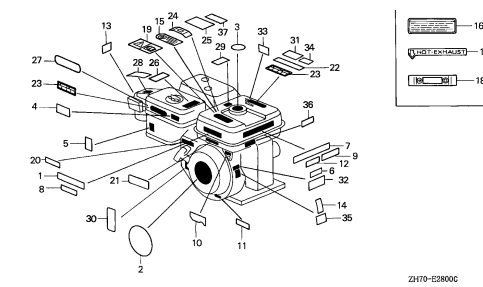

**E-29**

TOOL(1)

**M16**

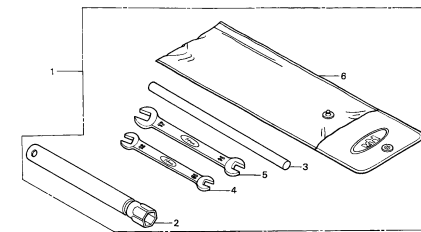

**2**



# ENGINE GROUP

**D 6**

**E-29-1**

TOOL(2)

**N 1**

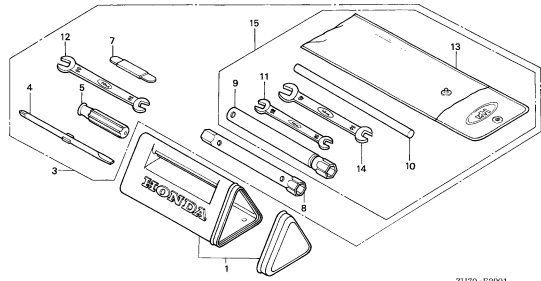

ZH70-E2901

**E-30**

TRANSMISSION

**N 3**

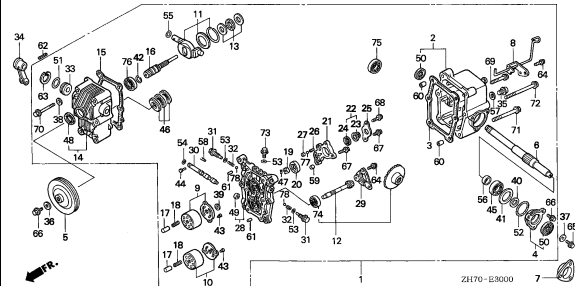

ZH70-E3000 7

**E-31**

OIL TANK

**N 6**

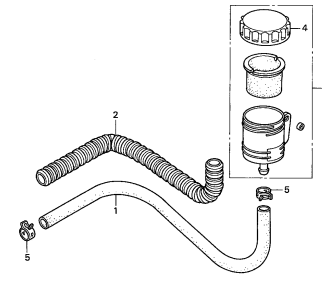

ZH70-E3100

**E-40**

ENGINE STOP SWITCH(OTHER PARTS)

**N 7**

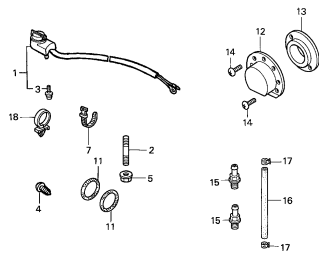

ZH70-E40008

**E-40-1**

FUEL TANK(OTHER PARTS)

**N 8**

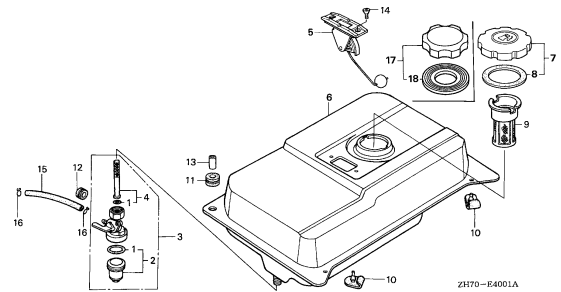

ZH70-E4001A

**E-40-2**

COOLING FAN(OTHER PARTS)

**N 9**

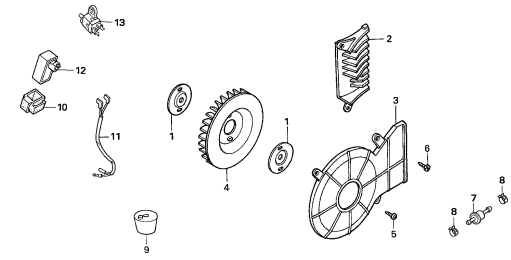

ZH70-E4002A

**EOP-1**

GASKET KIT

**N10**

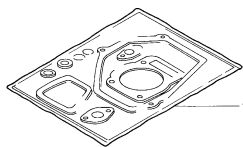

HEHO-X0003

**2**

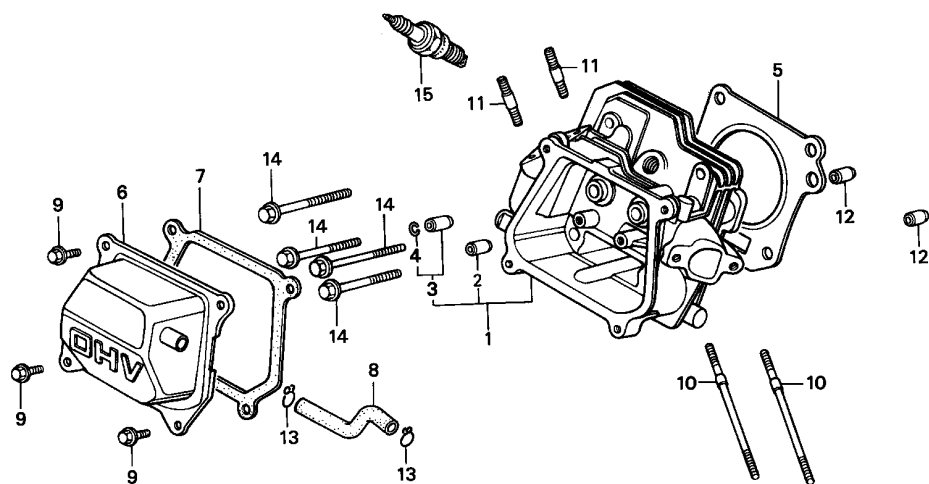

ZH70-E0200

Ref. No.	L.O.N.	(Relative ref. Number) Description	F.R.T.
1	1111N3	HEAD, CYLINDER .....	0.9
2	1111E9	GUIDE, INTAKE VALVE .....	0.8
	1111E9E	.With intake and exhaust all add .....	0.2
3	1111E8	GUIDE, EXHAUST VALVE .....	0.8
	1111E8E	.With intake and exhaust all add .....	0.2
5	1111N4	GASKET, CYLINDER HEAD .....	0.5
6	1111D5	COVER, CYLINDER HEAD AND/OR PACKING, HEAD COVER .....	0.1
8	1111K5	TUBE, BREATHER .....	0.1
10	1111A5	BOLT, STUD :INTAKE .....	0.2
	1111A5A	.For one add .....	0.1
11	1111A6	BOLT, STUD :EXHAUST .....	0.2
	1111A6A	.For one add .....	0.1
15	6141C1	PLUG, SPARK .....	0.1

Ref. No.	Part No.	Description	Reqd. QTY				Serial No.	Parts catalogue code
			(1)	(2)	(3)	(4)		
1	12210-ZH7-000	HEAD COMP., CYLINDER .....	1	1	-	-	-----	EN,ET,ETX,HH,HXQ,LDB1,LDB3,LD4,LE,LJT,LTA,LW2,PM2,QAA2,QA26,QBU2,QE,QH2,QJW1,QMH,QPU,QSJ,QXC,QXG,QXQ,QXS,RH,SAD2,SDB1,SSK1,SSK2,SW2,U1,VA,VAX4,VH,VS,VS1,V1,WDJ,WJ1,W1
	12210-ZH7-010	.....	-	-	-	1	-----	LEH4,LX26,PH,PM,QEH,QT2,QXG2,SDB3,SKJ,SN,TH,UH,UIH,UX,WJP1
	12210-ZH7-405	.....	1	1	1	-	-----	AR,DKR,DS,HHQ4,HTF2,HT2,HX,HXU,HX2,HX26,HX4,H1,KR,KRA4,KRF4,KRS4,KRT,KRT4,KRT6,LAJ4,LD,LH,LHQ4,LJ,LJC,LJD2,LJS,LSJ,LSJ4,LTJ,LTK1,LTR,LTS,LX,LXU,LX2,LX4,L1,PX,PX2,QA,QA2,QB26,QD,QH,QHQ4,QH26,QIH1,QJG2,QLL,QM,QMA4,QMA8,QME4,QMX2,QT,QWA4,QX,QXC9,QXS2,QXU,QX2,QX26,QX4,QX7,Q1,RD,RD4,RHC,RHQ4,RX,RX4,R1,SAJ,SAJ4,SCJ,SD,SD16,SD4,SE,SG24,SH,SHQ4,SJ,SJC,SJC1,SJC5,SJD2,SKR,SMA7,SMJ,SMW2,SM11,SM12,SM14,SSK3,SSX2,SSX4,STP,STS,SWX2,SWX4,SX,SXS4,SX4,SX7,S1,TX,TX2,TX26,TX4,UXU,VED,VED1,VED6,VEE1,VEK,VET,VEX,VEX7,VMS4,VMT,VPR4,VSX,VSX1,VX,VXU,VX4,VX7,WDA6,WD12,WI1,WJ,WJP,WKD6,WKT2,WKT4,WKT6,WMA3,WME2,WME4,WM1
2	12204-ZE1-305	GUIDE, IN. VALVE (O.S.) .....	(1)	-	-	-	-----	2156734 DS,EN,ET,ETX,HH,HX,LD,LE,LH,LJ,LW2,LX,PH,PM,PM2,PX,QA,QD,QE,QH,QM,QSJ,QT,QX,QXC,QXG,QXS,RD,RH,RX,SD,SE,SH,SJ,SMJ,SN,STS,SW2,SX,TH,TX,UH,UX,VA,VED,VED1,VET,VH,VS,VSX,VX,WJ
			-	(1)	-	-	-----	2156734



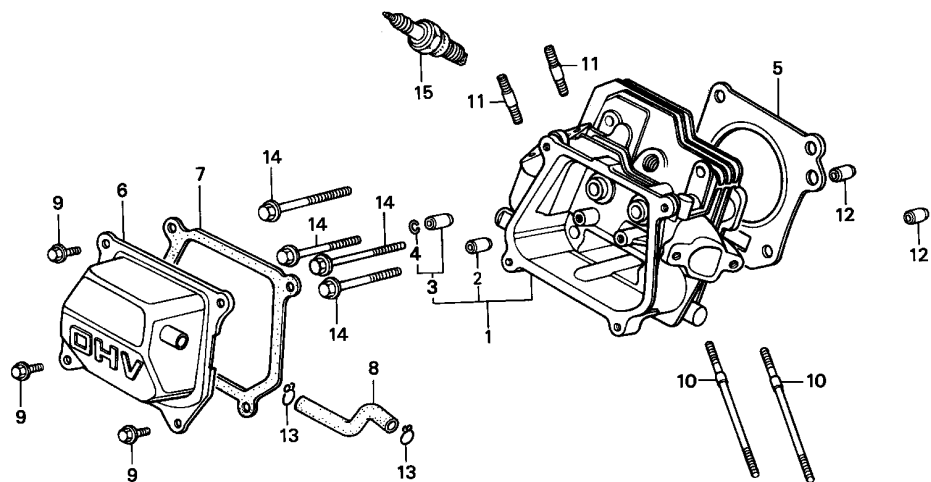

ZH70-E0200



Ref. No.	Part No.	Description	Reqd. QTY				Serial No.	Parts catalogue code	
			(1)	(2)	(3)	(4)			
(2)	12204-ZE1-306	GUIDE, IN. VALVE (O.S.)	(1)	-	-	-	-----	AR,DKR,HHQ4,HTF2,HT2,HXQ,HXU,HX2,HX26,HX4,KR,KRA4,KRF4,KRS4 KRT,KRT4,KRT6,LAJ4,LDB1,LDB3,LD4,LEH4,LHQ4,LJC,LJD2,LJS,LJT LSJ,LSJ4,LTA,LTJ,LTK1,LTR,LTS,LXU,LX2,LX26,LX4,PX2,QAA2,QA2 QA26,QBU2,QB26,QEH,QHQ4,QH2,QH26,QJG2,QJW1,QLL,QMA4,QMA8,QME4 QMH,QMX2,QPU,QTC2,QWA4,QXC9,QXG2,QXQ,QXS2,QXU,QX2,QX26,QX4,QX7 RD4,RHC,RHQ4,RX4,SAD2,SAJ,SAJ4,SCJ,SDB1,SDB3,SD16,SD4,SG24 SHQ4,SJC,SJC1,SJC5,SJD2,SKJ,SKR,SMA7,SMW2,SM11,SM12,SM14,SSK1 SSK2,SSK3,SSX2,SSX4,STP,SWX2,SWX4,SXS4,SX4,SX7,TX2,TX26,TX4 UXU,VAX4,VED6,VEE1,VEK,VEX,VEX7,VMS4,VMT,VPR4,VSX1,VS1,VXU,VX4 VX7,WDA6,WDJ,WD12,WJP,WJP1,WJ1,WKD6,WKT2,WKT4,WKT6,WMA3,WME2 WME4,WM1	
			(1)	-	-	-	2156735	-----	DS,EN,ET,ETX,HH,HX,LD,LE,LH,LJ,LW2,LX,PH,PM,PM2,PX,QA,QD,QE,QH QM,QSJ,QT,QX,QXC,QXG,QXS,RD,RH,RX,SD,SE,SH,SJ,SMJ,SN,STS,SW2 SX,TH,TX,UH,UX,VA,VED,VED1,VET,VH,VS,VSX,VX,WJ
			-	(1)	-	-	2156735		
3	12205-ZE1-315	GUIDE, EX. VALVE (O.S.)	(1)	(1)	(1)	(1)			
4	12216-ZE5-300	CLIP, VALVE GUIDE	1	1	1	1			
5	12251-ZF0-000	GASKET, CYLINDER HEAD	1	-	-	-	2157159	-----	DS,EN,ET,ETX,LJ,LW2,PM,PM2,QM,QSJ,QT,SJ,SMJ,SN,STS,SW2,VET,WJ
			-	(1)	-	-	2157159	-----	2157159
			-	-	1	-	-----	-----	UIH
			-	-	-	1			

Ref. No.	Part No.	Description	Reqd. QTY				Serial No.	Parts catalogue code
			(1)	(2)	(3)	(4)		
(5)	12251-ZH7-800	GASKET, CYLINDER HEAD .....	1	-	1	-	-----	AR,DKR,HH,HHQ4,HTF2,HT2,HX,HXQ,HXU,HX2,HX26,HX4,KR,KRA4,KRF4,KRS4,KRT,KRT4,KRT6,LAJ4,LD,LDB1,LDB3,LD4,LE,LEH4,LH,LHQ4,LJC,LJD2,LJS,LJT,LSJ,LSJ4,LTA,LTJ,LTJ,LTJ,LTK1,LTR,LTS,LX,LXU,LX2,LX26,LX4,PH,PX,PX2,QA,QAA2,QA2,QA26,QBU2,QB26,QD,QE,QEH,QH,QHQ4,QH2,QH26,QIH1,QJG2,QJW1,QLL,QMA4,QMA8,QME4,QMH,QMX2,QPU,QTC2,QWA4,QX,QXC,QXC9,QXG,QXG2,QXQ,QXS,QXS2,QXU,QX2,QX26,QX4,QX7,RD,RD4,RH,RHC,RHQ4,RX,RX4,SAD2,SAJ,SAJ4,SCJ,SD,SDB1,SDB3,SD16,SD4,SE,SG24,SH,SHQ4,SJC,SJC1,SJC5,SJD2,SKJ,SKR,SMA7,SMW2,SM11,SM12,SM14,SSK1,SSK2,SSK3,SSX2,SSX4,STP,SWX2,SWX4,SWX4,SX,SXS4,SX4,SX7,TH,TX,TX2,TX26,TX4,UH,UX,UXU,VA,VAX4,VED,VED1,VED6,VEE1,VEK,VEX,VEX7,VH,VMS4,VMT,VPR4,VS,VSX,VSX1,VS1,VX,VXU,VX4,VX7,WDA6,WDJ,WD12,WIH1,WJP,WJP1,WJ1,WKD6,WKT2,WKT4,WKT6,WMA3,WME2,WME4,WM1,DS,EN,ET,ETX,LJ,LW2,PM,PM2,QM,QSJ,QT,SJ,SMJ,SN,STS,SW2,VET,WJ
			1	-	-	-	2157160	-----
			-	(1)	-	-	2157160	-----
6	12310-ZE1-000	COVER COMP., HEAD .....	1	-	1	-	-----	2533057 EN,ET,ETX,HH,LD,LE,LH,LW2,LX,PH,PM,PM2,PX,QD,QE,QEH,QH,QLL,QM,QPU,QT,RD,RH,RHC,RX,SD,SE,SH,SN,SW2,SX,TH,UH,UIH,UX,VA,VED,VED1,VEX,VH,VS,VSX,VSX1,VS1,VX
			1	-	-	-	-----	HTF2,PX2,QBU2,QMX2,QTC2,SAD2,SAJ,SMW2,SSK2
			1	-	-	-	-----	2528940 LDB1,SDB1,VAX4
			1	-	-	-	-----	2533290 DS,LJ,LTA,LTJ,QSJ,SCJ,SJ,SKJ,SMJ,SSK1,VET,WJ,WJP
			1	-	-	-	-----	2535087 QMA4,QMA8,SMA7,WMA3
			1	-	-	-	-----	2538119 SJC,SSK3
			1	-	-	-	-----	2539585 HX2,LX2,QAA2,QA2,QH2,QXG2,QXS2,QX2,TX2
			-	1	-	-	-----	2115473
			-	-	1	-	-----	2533057
			-	(1)	-	-	-----	U1
			-	(1)	-	-	-----	2115474
			-	-	-	-	-----	2538109 H1,L1,Q1,R1,S1,V1,W1
12310-ZE1-010	.....	.....	1	-	1	-	-----	LDB3,LD4,LEH4,LJT,QA26,QIH1,QJW1,QMH,QXG,QXS,SDB3,WDJ,WIH1,WJ1
			1	-	1	-	-----	2533058 EN,ET,ETX,HH,LE,LW2,PM2,QE,QEH,QPU,RH,SN,SW2,UIH,VA,VH,VS,VS1
			1	-	-	-	-----	2528941 LDB1,SDB1,VAX4
			1	-	-	-	-----	2533291 LTA,QSJ,SSK1
			1	-	-	-	-----	2538120 SJC
			1	-	-	-	-----	2539586 QAA2,QH2
			1	-	-	-	-----	3909674 AR,DKR,HHQ4,HX,HXU,HX26,HX4,KR,KRA4,KRT,KRT4,KRT6,LAJ4,LHQ4,LJC,LJD2,LJS,LSJ,LSJ4,LTK1,LTR,LXU,LX26,LX4,QA,QB26,QHQ4,QH2,QJG2,QME4,QWA4,QX,QXU,QX26,QX4,RD4,RHQ4,RX4,SAJ4,SD16,SD4,SG24,SHQ4,SJC1,SJC5,SKR,SSX2,SSX4,SWX2,SWX4,SXS4,SX4,TX,TX26,TX4,UXU,VED6,VEE1,VMS4,VMT,VPR4,VXU,VX4,WDA6,WD12,WJP1,WKD6,WKT2,WKT4,WME2,WME4,WM1
			1	-	-	-	2533058	3909674 LD,LH,LX,PH,PM,PX,QD,QH,QLL,QM,QT,RD,RHC,RX,SD,SE,SH,SX,TH,UH,UX,VED,VED1,VEX,VSX,VSX1,VX
			1	-	-	-	2533291	3909674 DS,LJ,LTJ,SCJ,SJ,SKJ,SMJ,VET,WJ,WJP
			1	-	-	-	2535088	3909674 QMA4,QMA8,SMA7,WMA3
			1	-	-	-	2538120	3909674 SSK3
			1	-	-	-	2539586	3909674 HX2,LX2,QA2,QXG2,QXS2,QX2,TX2
			-	(1)	-	-	2538110	-----
			-	(1)	-	-	2538110	-----
			-	-	-	1	2533058	-----
			-	-	-	1	2533058	-----



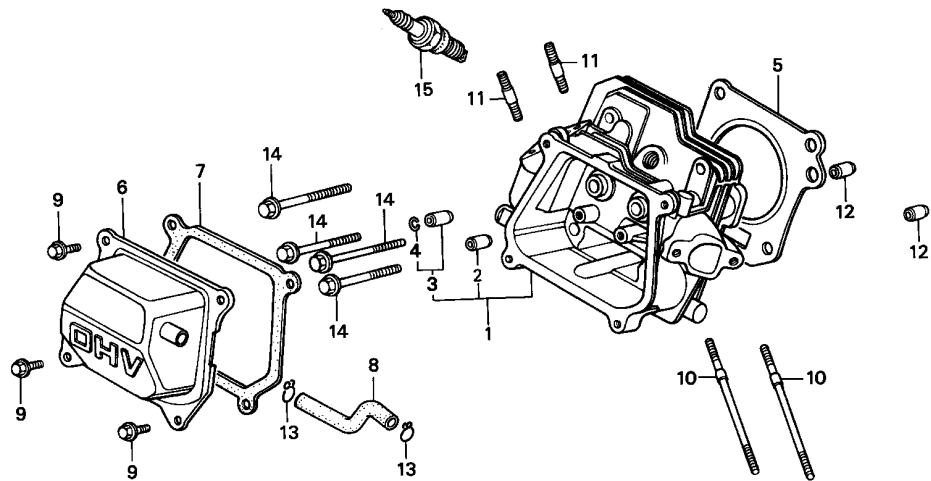

ZH70-E0200



2

Ref. No.	Part No.	Description	Reqd. QTY				Serial No.	Parts catalogue code
			(1)	(2)	(3)	(4)		
			GX120K1					
(6)	12310-ZE1-020	COVER COMP., HEAD	1	(1)	-	-	3909675	AR,DKR,DS,HHQ4,HTF2,HX,HXU,HX2,HX26,HX4,H1,KR,KRA4,KRT,KRT4 KRT6,LAJ4,LD,LH,LHQ4,LJ,LJC,LJD2,LJS,LSJ,LSJ4,LTJ,LTK1,LTR,LX LXU,LX2,LX26,LX4,PH,PM,PX,PX2,QA,QA2,QB26,QD,QH,QHQ4,QH26,QJG2 QLL,QM,QMA4,QMA8,QME4,QMX2,QT,QTC2,QWA4,QX,QXG2,QXS2,QXU,QX2 QX26,QX4,Q1,RD,RD4,RHC,RHQ4,RX,RX4,R1,SAJ,SAJ4,SCJ,SD,SD16,SD4 SE,SG24,SH,SHQ4,SJ,SJC1,SJC5,SKJ,SKR,SMA7,SMJ,SMW2,SSK3,SSX2 SSX4,SWX2,SWX4,SX,SXS4,SX4,TH,TX,TX2,TX26,TX4,UH,UX,UXU,VED VED1,VED6,VEE1,VEE2,VET,VEX,VMS4,VMT,VPR4,VSX,VSX1,VX,VXU,VX4,WDA6 WD12,WJ,WJP,WJP1,WKD6,WKT2,WKT4,WMA3,WME2,WME4,WM1 HT2,KRF4,KRS4,LTS,QX7,SJD2,SM11,SM12,SM14,SX7,VEK,VEX7,VX7 WKT6
	12310-ZE1-840	COVER COMP., HEAD (BREATHER TUBE)	1	-	-	-	2575980	HXQ,QXC,QXC9,QXQ,STP,STS
	12310-ZE1-841	.....	1	(1)	-	-	2115474	
	12310-ZE1-841	.....	1	-	-	-	2575981	HXQ,QXC,QXQ
	12310-ZE1-842	.....	1	-	-	-	3909674	QXC9,STP,STS
	12310-ZE1-842	.....	1	-	-	-	3909675	QXC9,STP,STS
7	12391-ZE1-000	PACKING, HEAD COVER	1	1	1	1		

Ref. No.	Part No.	Description	Reqd. QTY				Serial No.	Parts catalogue code
			(1)	GX120K1 (2)	(3)	(4)		
8	15721-ZH8-000	TUBE, BREATHER .....	1	-	-	-	-----	AR,DKR,DS,EN,ET,ETX,HH,HHQ4,HTF2,HT2,HX,HXU,HX2,HX26,HX4,KR KRA4,KRF4,KRS4,KRT,KRT4,KRT6,LAJ4,LD,LDB1,LDB3,LD4,LE,LEH4,LH LHQ4,LJ,LJC,LJD2,LJS,LJT,LSJ,LSJ4,LTA,LTJ,LTK1,LTR,LTS,LW2,LX LXU,LX2,LX26,LX4,PH,PM,PM2,PX,PX2,QA,QAA2,QA2,QA26,QBU2,QB26 QD,QE,QEH,QH,QHQ4,QH2,QH26,QJG2,QJW1,QLL,QM,QMA4,QMA8,QME4,QMH QMX2,QPU,QSJ,QT,QTC2,QWA4,QX,QXG,QXG2,QXS,QXS2,QXU,QX2,QX26 QX4,QX7,RD,RD4,RH,RHC,RHQ4,RX,RX4,SAD2,SAJ,SAJ4,SCJ,SD,SDB1 SDB3,SD16,SD4,SE,SG24,SH,SHQ4,SJ,SJC,SJC1,SJC5,SJD2,SKJ,SKR SMA7,SMJ,SMW2,SM11,SM12,SM14,SN,SSK1,SSK2,SSK3,SSX2,SSX4,SWX2 SWX4,SW2,SX,SXS4,SX4,SX7,TH,TX,TX2,TX26,TX4,UH,UX,UXU,VA,VAX4 VED,VED1,VED6,VEE1,VEK,VET,VEX,VEX7,VH,VMS4,VS,VSX,VSX1,VS1,VX VXU,VX4,VX7,WDA6,WDJ,WD12,WJ,WJP,WJP1,WJ1,WKD6,WKT2,WKT4,WKT6 WMA3,WME2,WME4,WM1
			-	1	-	-	-----	2115473
	15721-883-030	.....	1	-	-	-	-----	VMT,VPR4
	15721-ZE1-840	.....	1	-	-	-	-----	HXQ,QXC,QXC9,QXQ,STP,STS
			-	(1)	-	-	-----	2115474
9	90016-ZE1-000	BOLT, FLANGE, 6X13(CT200) ...	4	-	-	-	-----	2299856 DS,EN,ET,ETX,HH,HX,HXQ,HX2,LD,LE,LH,LJ,LTA,LTJ,LW2,LX,LX2,PH PM,PM2,PX,QA,QA2,QD,QE,QEH,QH,QH2,QM,QSJ,QT,QX,QXC,QXG,QXG2 QXQ,QXS,QXS2,QX2,RD,RH,RX,SD,SE,SH,SJ,SKJ,SMJ,SN,STS,SW2,SX,TH TX,TX2,UH,UX,VA,VED,VED1,VET,VEX,VH,VS,VSX,VSX1,VS1,VX,WJ
			-	4	-	-	-----	2299856
	90013-883-000	BOLT, FLANGE, 6X12(CT200) ...	4	-	-	-	-----	AR,DKR,HHQ4,HTF2,HT2,HXU,HX26,HX4,KR,KRA4,KRF4,KRS4,KRT,KRT4 KRT6,LAJ4,LDB1,LDB3,LD4,LEH4,LHQ4,LJC,LJD2,LJS,LJT,LSJ,LSJ4 LTK1,LTR,LTS,LXU,LX26,LX4,PX2,QAA2,QA26,QBU2,QB26,QHQ4,QH26 QJG2,QJW1,QLL,QMA4,QMA8,QME4,QMH,QMX2,QPU,QTC2,QWA4,QXC9,QXU QX26,QX4,QX7,RD4,RHC,RHQ4,RX4,SAD2,SAJ,SAJ4,SCJ,SDB1,SDB3,SD16 SD4,SG24,SHQ4,SJC,SJC1,SJC5,SJD2,SKR,SMA7,SMW2,SM11,SM12,SM14 SSK1,SSK2,SSK3,SSX2,SSX4,STP,SWX2,SWX4,SXS4,SX4,SX7,TX26,TX4 UXU,VAX4,VED6,VEE1,VEK,VEX7,VMS4,VMT,VPR4,VXU,VX4,VX7,WDA6,WDJ WD12,WJP,WJP1,WJ1,WKD6,WKT2,WKT4,WKT6,WMA3,WME2,WME4,WM1
			4	-	-	-	-----	2299857
			-	4	-	-	-----	2299857
			-	-	4	4	-----	
10	90043-ZE1-010	BOLT, STUD, 6X109 .....	2	2	2	-	-----	2400125 EN,ET,ETX,HH,HX,H1,LD,LE,LH,LW2,LX,L1,PH,PM,PM2,PX,QA,QD,QE QEH,QH,QLL,QM,QPU,QT,QX,QXC,QXG,QXS,Q1,RD,RH,RHC,RX,R1,SD,SE SH,SN,SW2,SX,S1,TH,TX,UH,UIH,UX,VA,VED,VED1,VEX,VH,VS,VSX,VSX1 VS1,VX,V1,W1
			2	-	-	-	-----	2401319 DS,LJ,LTA,LTJ,QSJ,SCJ,SJ,SKJ,SMJ,STS,VET,WJ
			2	-	-	-	-----	2402519 HXQ,HX2,LX2,QA2,QH2,QXG2,QXQ,QXS2,QX2,TX2
			-	2	-	-	-----	U1
			-	-	-	2	-----	2400125
	90043-ZB2-003	BOLT, STUD, 6X94 .....	2	-	-	-	-----	VMT,VPR4



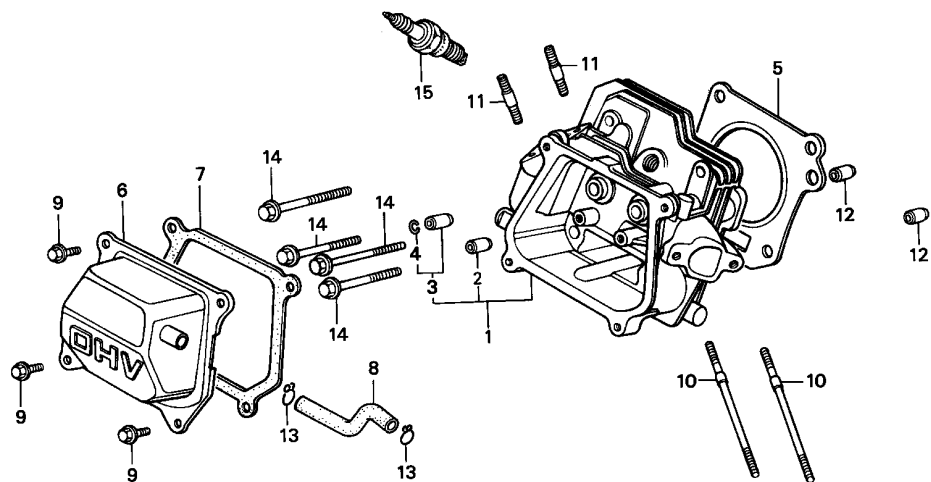

ZH70-E0200



2

Ref. No.	Part No.	Description	Reqd. QTY				Serial No.	Parts catalogue code
			(1)	(2)	(3)	(4)		
10)	90043-ZE1-020	BOLT, STUD, 6X112 .....	2	2	2	-	2400126	EN,ET,ETX,HH,HX,H1,LD,LE,LH,LW2,LX,L1,PH,PM,PM2,PX,QA,QD,QE,QEH,QH,QLL,QM,QPU,QT,QX,QXC,QXG,QXS,Q1,RD,RH,RHC,RX,R1,SD,SE,SH,SN,SW2,SX,S1,TH,TX,UH,UIH,UX,VA,VED,VED1,VEX,VH,VS,VSX,VSX1,VS1,VX,V1,W1
			2	-	2	-	-----	AR,DKR,HHQ4,HTF2,HT2,HXU,HX26,HX4,KR,KRA4,KRF4,KRS4,KRT,KRT4,KRT6,LAJ4,LDB1,LDB3,LD4,LEH4,LHQ4,LJC,LJD2,LJS,LJT,LSJ,LSJ4,LTK1,LTR,LTS,LXU,LX26,LX4,PX2,QAA2,QA26,QBU2,QB26,QHQ4,QH26,QIH1,QJG2,QJW1,QMA4,QMA8,QME4,QMH,QMX2,QTC2,QWA4,QXC9,QXU,QX26,QX4,QX7,RD4,RHQ4,RX4,SAD2,SAJ,SAJ4,SDB1,SDB3,SD16,SD4,SG24,SHQ4,SJC,SJC1,SJC5,SJD2,SKR,SMA7,SMW2,SM11,SM12,SM14,SSK1,SSK2,SSK3,SSX2,SSX4,STP,SWX2,SWX4,SXS4,SX4, SX7, TX26, TX4, UXU, VAX4, VED6, VEE1, VEK, VEX7, VMS4, VXU, VX4, VX7, WDA6, WDJ, WD12, WIH1, WJP, WJP1, WJ1, WKD6, WKT2, WKT4, WKT6, WMA3, WME2, WME4, WM1
			2	-	-	-	2401320	----- DS,LJ,LTA,LTJ,QSJ,SCJ,SJ,SKJ,SMJ,STS,VET,WJ
			2	-	-	-	2402520	----- HXQ,HX2,LX2,QA2,QH2,QXG2,QXQ,QXS2,QX2,TX2
			-	-	-	2	2400126	
11	90047-ZE1-000	BOLT, STUD, 8X32 .....	2	2	2	2		
12	94301-10160	DOWEL PIN, 10X16 .....	2	2	2	2		
13	95002-80000	CLIP, TUBE (C12) .....	2	-	-	-	-----	HXQ,QXC,QXC9,QXQ,STP,STS
			-	(2)	-	-	2115474	
14	95723-08055-00	BOLT, FLANGE, 8X55 .....	4	4	4	4		
15	98079-54841	PLUG, SPARK (BP4ES) (NGK) ....	1	-	-	-	-----	KRT6
			1	-	-	-	3235089	AR
			1	-	-	-	2912713	3491424 KR,KRT
			(1)	-	-	-	2912713	3235089 DKR
	98079-54846	PLUG, SPARK (BPR4ES) (NGK) ...	1	-	-	-	-----	KRA4,KRF4,KRS4,KRT4
			1	-	-	-	3235090	AR,DKR
			1	-	-	-	3491425	KR,KRT

Ref. No.	Part No.	Description	Reqd. QTY				Serial No.	Parts catalogue code	
			(1)	GX120K1 (2)	(3)	(4)			
15)	98079-55841	PLUG, SPARK (BP5ES) (NGK) ....	1	-	-	-	-----	VEK	
			(1)	-	1	-	-----	LTA,UIH,VS1	
			(1)	-	-	-	-----	2912712 DKR,KR,KRT	
			(1)	-	-	-	-----	3491424 VS	
			-	(1)	-	-	-	-	-
	98079-55846	PLUG, SPARK (BPR5ES) (NGK) ...	1	-	-	-	-----	LTR	
			1	-	-	-	3491425	-----	VS
			(1)	-	-	-	-----	HTF2,HT2,HX,HXQ,HXU,HX2,HX26,HX4,LAJ4,LEH4,LH,LHQ4,LJD2,LSJ4 LX,LXU,LX2,LX26,LX4,PX,PX2,QA,QAA2,QA2,QA26,QBU2,QB26,QEH,QH QHQ4,QH2,QH26,QJG2,QJW1,QLL,QME4,QMH,QMX2,QPU,QTC2,QX,QXC,QXG QXG2,QXQ,QXS,QXS2,QXU,QX2,QX26,QX4,QX7,RH,RHC,RHQ4,SAD2,SG24 SJD2,SMW2,SM11,SM14,SWX2,SWX4,TX,TX2,TX26,TX4,VED,VH,WDA6,WD12 WKD6,WKT2,WKT4,WKT6,WME2,WME4,WM1	
			(1)	-	-	-	2689723	-----	LD4,RD4,SD4,WMA3
			-	(1)	-	-	-	-	-
	98079-56841	PLUG, SPARK (BP6ES) (NGK) ....	1	-	1	-	-----	AR,DS,EN,ET,ETX,KRA4,LDB1,LJ,LJC,LJT,LSJ,LTA,LTK1,LW2,PM,PM2 QIH1,QM,QSJ,SAJ,SCJ,SJ,SJC,SJC1,SJC5,SKJ,SMJ,SN,SSK1,SSK3,STP STS,SW2,VEE1,VET,VS1,WDJ,WIH1,WJ,WJP,WJ1	
			1	-	-	-	2816332	-----	VSX,VSX1
			1	-	-	-	2689722	-----	LD4,RD4,SD4,WMA3
			1	-	-	-	2912712	-----	DKR,KR,KRT
			1	-	-	-	3171360	-----	WJP1
98079-56846	PLUG, SPARK (BPR6ES) (NGK) ...	1	-	-	1	-----	3491424 LD,LDB3,LTJ,QD,RD,SD,SDB1,SDB3,SKR,VED,VS,WM1		
		-	(1)	-	-	-	-		
		1	-	-	-	-----	HH,HHQ4,HTF2,HT2,HX,HXQ,HXU,HX2,HX26,HX4,LAJ4,LE,LEH4,LH,LHQ4 LJD2,LJS,LSJ4,LTS,LX,LXU,LX2,LX26,LX4,PH,PX,PX2,QA,QAA2,QA2 QA26,QBU2,QB26,QE,QEH,QH,QHQ4,QH2,QH26,QJG2,QJW1,QLL,QMA4,QMA8 QME4,QMH,QMX2,QPU,QTC2,QWA4,QX,QXC,QXC9,QXG,QXG2,QXQ,QXS,QXS2 QXU,QX2,QX26,QX4,QX7,RH,RHC,RHQ4,RX,RX4,SAD2,SAJ4,SD16,SE,SG24 SH,SHQ4,SMA7,SMW2,SM11,SM12,SM14,SSK2,SSX2,SSX4,SWX2,SWX4,SX SXS4,SX4,SX7,TH,TX,TX2,TX26,TX4,UH,UX,UXU,VA,VAX4,VED1,VED6 VEX,VEX7,VH,VMS4,VMT,VPR4,VX,VXU,VX4,VX7,WDA6,WD12,WKD6,WKT2 WKT4,WME2,WME4		
		1	-	-	-	2689723	-----	LD4,RD4,SD4,WMA3	
		1	-	-	-	3171361	-----	WJP1	
1	-	-	-	3491425	-----	DS,LD,LDB3,LJ,LJT,LSJ,LTJ,QD,RD,SAJ,SCJ,SD,SDB1,SDB3,SJ,SJC SJC1,SJC5,SKJ,SKR,SMJ,SSK1,SSK3,VED,VEE1,VET,VS,WDJ,WJ,WJP,WJ1 WM1			
98079-54854	PLUG, SPARK (W14EP-U) (DENSO)	1	-	-	-	-----	2816331 VSX,VSX1		
		(1)	-	-	-	-----	SJD2,VEK,WKT6		
		-	(1)	-	1	-	-	-	
		1	-	-	-	-----	KRT6		
		1	-	-	-	3235089	-----	AR	
98079-54855	PLUG, SPARK (W14EPR-U) (DENSO)	1	-	-	-	2912713	3491424 KR,KRT		
		(1)	-	-	-	2912713	3235089 DKR		
		1	-	-	-	-----	KRA4,KRF4,KRS4,KRT4		
98079-55854	PLUG, SPARK (W16EP-U) (DENSO)	1	-	-	-	3235090	-----	AR,DKR	
		1	-	-	-	3491425	-----	KR,KRT	
		1	-	-	-	-----	VEK		
			(1)	-	1	-	-----	LTA,UIH,VS,VS1	
			(1)	-	-	-	-----	2912712 DKR,KR,KRT	
			-	(1)	-	-	-	-	-





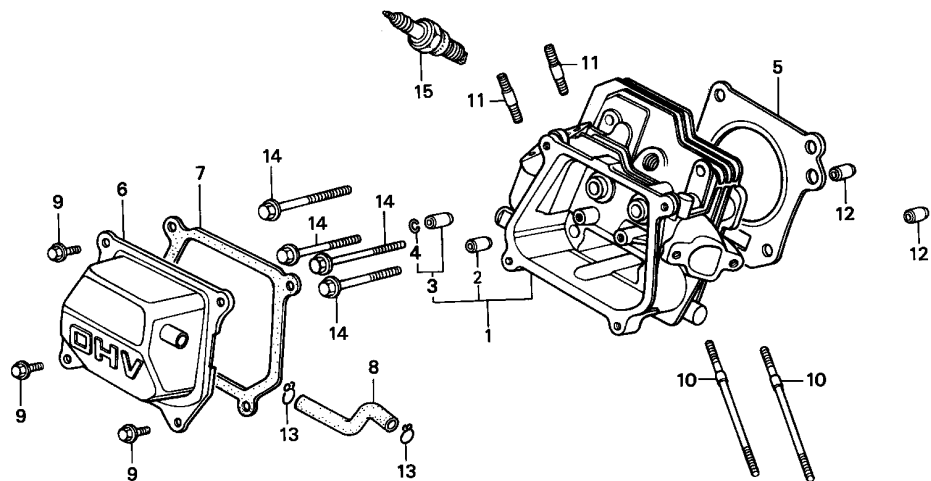

ZH70-E0200



Ref. No.	Part No.	Description	Reqd. QTY				Serial No.	Parts catalogue code	
			(1)	(2)	(3)	(4)			
15)	98079-55855	PLUG, SPARK (W16EPR-U) (DENSO)	1	-	-	-	-----	LTR	
			(1)	-	-	-	-----	HTF2, HT2, HX, HXQ, HXU, HX2, HX26, HX4, LAJ4, LEH4, LH, LHQ4, LJD2, LSJ4, LX, LXU, LX2, LX26, LX4, PX, PX2, QA, QAA2, QA2, QA26, QBU2, QB26, QEH, QHQ4, QH2, QH26, QJG2, QJW1, QLL, QME4, QMH, QMX2, QPU, QTC2, QX, QXC, QXG, QXG2, QXQ, QXS, QXS2, QXU, QX2, QX26, QX4, QX7, RH, RHC, RHQ4, SAD2, SG24, SJD2, SMW2, SM11, SM14, SWX2, SWX4, TX, TX2, TX26, TX4, VED, VH, VS, WDA6, WD12, WKD6, WKT2, WKT4, WKT6, WME2, WME4, WM1, LD4, RD4, SD4, WMA3	
	98079-56855	PLUG, SPARK (W20EPR-U) (DENSO)	1	-	-	-	-----	HH, HHQ4, HTF2, HT2, HX, HXQ, HXU, HX2, HX26, HX4, LAJ4, LE, LEH4, LH, LHQ4, LJD2, LSJ4, LX, LXU, LX2, LX26, LX4, PH, PX, PX2, QA, QAA2, QA2, QA26, QBU2, QB26, QE, QEH, QH, QHQ4, QH2, QH26, QJG2, QLL, QMA4, QMA8, QME4, QMH, QMX2, QPU, QTC2, QWA4, QX, QXC, QXC9, QXG, QXG2, QXQ, QXS, QXS2, QXU, QX2, QX26, QX4, QX7, RH, RHC, RHQ4, RX, RX4, SAD2, SAJ4, SD16, SE, SG24, SH, SHQ4, SJD2, SMA7, SMW2, SM11, SM12, SM14, SSK2, SSK2, SSK4, SWX2, SWX4, SX, SXS4, SX4, SX7, TH, TX, TX2, TX26, TX4, UH, UX, UXU, VA, VAX4, VED1, VED6, VEX, VEX7, VH, VMS4, VMT, VPR4, VXU, VX4, VX7, WDA6, WD12, WKD6, WKT2, WKT4, WKT6, WME2, WME4	
			1	-	-	-	2689723	-----	LD4, RD4, SD4, WMA3
			-	(1)	-	-	3491425	-----	LD, LDB3, QD, RD, SD, SDB1, SDB3, VED, VS, WM1
			1	-	-	-	2816331	-----	VSX, VSX1
			(1)	-	-	-	-----	VEK	
			-	(1)	-	1	-----		

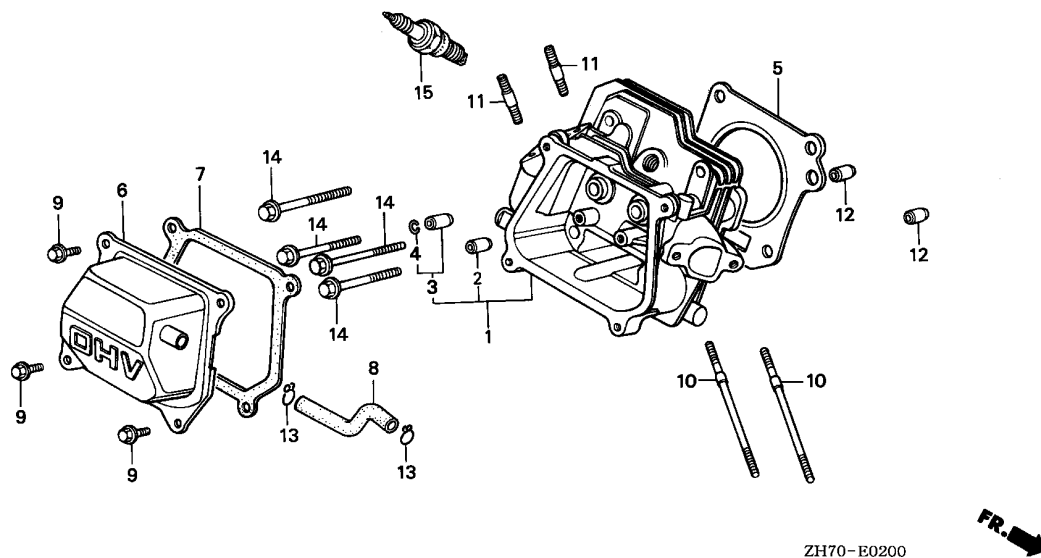

Ref. No.	Part No.	Description	Reqd. QTY				Serial No.	Parts catalogue code
			(1)	GX120K1 (2)	(3)	(4)		
15)	98079-56854	PLUG, SPARK (W20EP-U) (DENSO)	1	-	(1)	-	-----	EN,ET,ETX,LD,LDB1,LDB3,LJC,LTA,LTK1,LW2,PM,PM2,QD,QM,QSJ,QT,RD SD,SDB1,SDB3,SN,STP,STS,SW2,UIH,VED,VS,VS1,WIH1,WM1
			1	-	-	-	2816332	----- VSX,VSX1
			1	-	-	-	2689722	----- LD4,RD4,SD4,WMA3
			1	-	-	-	2912712	----- DKR,KR,KRT
			1	-	-	-	2923462	----- WJP1
			1	-	-	-	3491424	----- DS,LJ,LJT,LSJ,LTJ,SAJ,SCJ,SJ,SJC,SJC1,SJC5,SKJ,SKR,SMJ,SSK1 SSK3,VEE1,VET,WDJ,WJ,WJP,WJ1
	98079-56855	PLUG, SPARK (W20EPR-U) (DENSO)	-	(1)	-	-	-----	HT2,HX,H1,LJS,LTS,LX,PH,PX,QJW1,QX,Q1,RX,R1,SJD2,SM11,SM14,SX TH,UH,UX,U1,VH,VX,V1,W1
			1	(1)	-	-	-----	HT2,HX,H1,LJS,LTS,LX,PH,PX,QJW1,QX,Q1,RX,R1,SJD2,SM11,SM14,SX TH,UH,UX,U1,VH,VX,V1,W1
			1	-	-	-	2923463	----- WJP1
			1	-	-	-	3491425	----- DS,LD,LJ,LJT,LSJ,LTJ,QD,RD,SAJ,SCJ,SD,SJ,SJC,SJC1,SJC5,SKJ,SKR SMJ,SSK1,SSK3,VEE1,VET,WDJ,WJ,WJP,WJ1
			(1)	-	-	-	-----	VEK

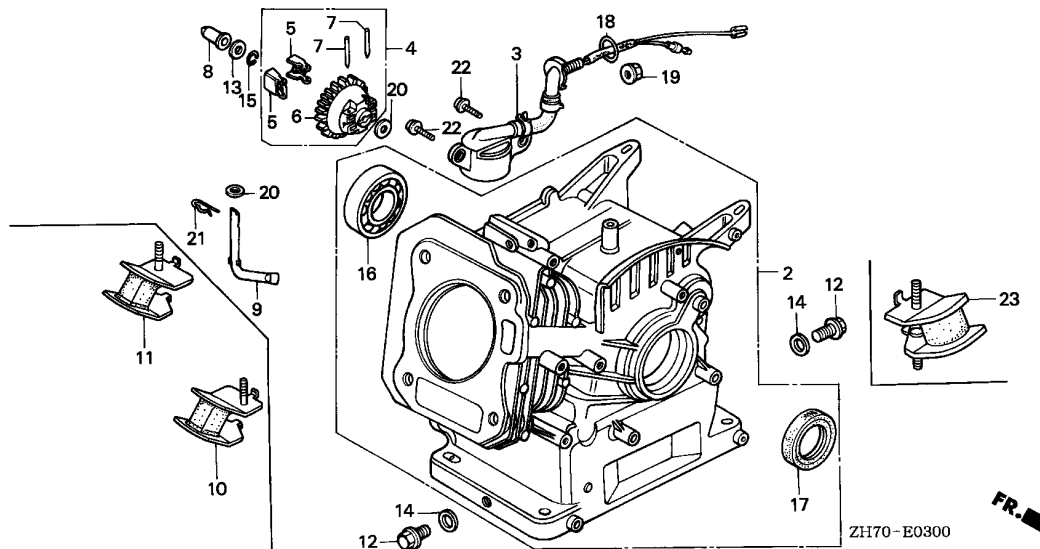

Ref. No.	L.O.N.	(Relative ref. Number) Description	F.R.T.
2	1101A0	BARREL, CYLINDER .....	2.0
3		(18)	
6	6151E8	SWITCH, OIL LEVEL .....	0.5
6		(5)	
9	1161A7	HOLDER, GOVERNOR WEIGHT .....	0.9
8	1161B6	SLIDER, GOVERNOR .....	0.4
9	1161B4	SHAFT, GOVERNOR ARM .....	0.9
16	1101A4	BEARING, CRANKSHAFT :FRONT ...	1.3
17	1101E4	OIL SEAL, CRANKSHAFT :FRONT ..	1.2

2

Ref. No.	Part No.	Description	Reqd. QTY				Serial No.	Parts catalogue code
			(1)	(2)	(3)	(4)		
2	12000-ZF0-405	BARREL ASSY., CYLINDER .....	1	(1)	1	-	EN,ET,HH,LDB1,LDB3,LD4,LE,LEH4,LJT,LW2,PH,PM,PM2,QAA2,QA26,QE QEH,QH2,QPU,QSJ,RH,QMA4,QME4,QT,Q1,RD,RD4,RHC,RHQ4,R1,SAJ,SAJ4 VS,VS1,V1,WDJ,WJP1,WJ1	
			1	-	-	2564425	QXG2	
	12000-ZH7-405	.....	1	(1)	-	-	ETX,HXQ,LTA,LX26,QBU2,QJW1,QMH,QTC2,QXC,QXG,QXQ,QXS,SAD2,UX,U1 VA,VAX4,V1	
			1	-	-	2564424	QXG2	
	12000-ZF0-415	.....	1	(1)	-	-	4205163 AR,DKR,DS,HHQ4,HT2,H1,KR,KRA4,KRF4,KRS4,KRT,KRT4,KRT6,LAJ4,LD LH,LHQ4,LJ,LJD2,LJS,LSJ,LSJ4,LTJ,LTK1,LTR,L1,QA,QA2,QB26,QD,QH QHQ4,QH26,QJG2,QM,QMA4,QME4,QT,Q1,RD,RD4,RHC,RHQ4,R1,SAJ,SAJ4 SCJ,SD,SD16,SD4,SE,SH,SHQ4,SJ,SJC,SJD2,SKR,SM11,SSK1,SSK3,STP STS,S1,VED,VEK,VET,WDA6,WD12,WJ,WJP,WMA3,WME4,WM1,W1	
			-	-	1	-	QIH1,WIH1	
	12000-ZH7-415	BARREL ASSY., CYLINDER (OIL ALERT)	1	(1)	-	-	4205163 HTF2,HX,HXU,HX2,HX26,HX4,H1,LJC,LX,LXU,LX2,LX4,L1,PX,PX2,QLL QMA8,QMX2,QWA4,QX,QXC9,QXS2,QXU,QX2,QX26,QX4,QX7,Q1,RX,RX4,R1 SG24,SJC1,SJC5,SMA7,SMJ,SMW2,SM12,SM14,SSX2,SSX4,SWX2,SWX4,SX SXS4,SX4,SX7,S1,TX,TX2,TX26,TX4,UXU,VED1,VED6,VEE1,VEX,VEX7 VMS4,VMT,VPR4,VSX,VSX1,VX,VXU,VX4,VX7,WKD6,WKT2,WKT4,WKT6,WME2 W1	
			1	(1)	-	-	4205164 AR,DKR,DS,HHQ4,HT2,H1,KR,KRA4,KRF4,KRS4,KRT,KRT4,KRT6,LAJ4,LD LH,LHQ4,LJ,LJD2,LJS,LSJ,LSJ4,LTJ,LTK1,LTR,L1,QA,QA2,QB26,QD,QH QHQ4,QH26,QJG2,QM,QMA4,QME4,QT,Q1,RD,RD4,RHC,RHQ4,R1,SAJ,SAJ4 SCJ,SD,SD16,SD4,SE,SH,SHQ4,SJ,SJC,SJD2,SKR,SM11,SSK1,SSK3,STP STS,S1,VED,VEK,VET,WDA6,WD12,WJ,WJP,WMA3,WME4,WM1,W1	
			1	-	-	-	LTS	

Ref. No.	Part No.	Description	Reqd. QTY				Serial No.	Parts catalogue code
			(1)	GX120K1 (2)	(3)	(4)		
(2)	12000-ZH7-425	BARREL ASSY., CYLINDER .....	1	(1)	-	-	4205164 -----	HTF2,HX,HXU,HX2,HX26,HX4,H1,LJC,LX,LXU,LX2,LX4,L1,PX,PX2,QLL,QMA8,QMX2,QWA4,QX,QXC9,QXS2,QXU,QX2,QX26,QX4,QX7,Q1,RX,RX4,R1,SG24,SJC1,SJC5,SMA7,SMJ,SMW2,SM12,SM14,SSX2,SSX4,SWX2,SWX4,SX,SXS4,SX4,SX7,S1,TX,TX2,TX26,TX4,UXU,VED1,VED6,VEE1,VEX,VEX7,VMS4,VMT,VPR4,VSX,VSX1,VX,VXU,VX4,VX7,WKD6,WKT2,WKT4,WKT6,WME2,W1
3	15510-ZE1-003	SWITCH ASSY., OIL LEVEL .....	1	-	-	-	-----	2186369 ETX,HX,LX,PX,QX,QXC,QXG,QXS,RX,SMJ,SX,TX,UX,VA,VED1,VSX,VX
	15510-ZE1-013	.....	-	(1)	-	-	-----	2186369
			1	(1)	-	-	2186370	2867760 ETX,HX,LX,PX,QX,QXC,QXG,QXS,Q1,RX,R1,SMJ,SX,S1,TX,UX,VA,VED1,VSX,VX,V1,W1
			1	-	-	-	-----	2564424 QXG2
			1	-	-	-	-----	2867760 HTF2,HXQ,HX2,HX26,HX4,LTA,LX2,LX26,LX4,PX2,QBU2,QLL,QMA8,QMX2,QTC2,QXC9,QXQ,QXS2,QX2,QX26,QX4,RX4,SAD2,SG24,SJC1,SMA7,SMW2,SSX4,SX4,TX2,TX26,TX4,VAX4,VEX,VPR4,VSX1,VX4,WKT2,WME2
	15510-ZE1-023	.....	-	(1)	-	-	2186370	-----
			1	(1)	-	-	2867761	-----
			1	(1)	-	-	2867761	3327460 HTF2,HX,HX2,HX26,HX4,LTA,LX,LX2,LX26,LX4,PX,PX2,QLL,QMA8,QMX2,QTC2,QX,QXC,QXC9,QXS2,QX2,QX26,QX4,Q1,RX,RX4,R1,SG24,SJC1,SMA7,SMJ,SMW2,SSX4,SX,SX4,S1,TX,TX2,TX26,TX4,UX,VAX4,VED1,VEX,VPR4,VSX,VSX1,VX,VX4,WKT2,WME2,W1
	15510-ZE1-033	.....	1	-	-	-	-----	3327460 HXU,LJC,LXU,QJW1,QMH,QXU,SJC5,UXU,VEE1,VMS4,VXU
			1	(1)	-	-	3327461	-----
								HTF2,HX,HXU,HX2,HX26,HX4,LJC,LTA,LX,LXU,LX2,LX26,LX4,PX,PX2,QJW1,QLL,QMA8,QMH,QMX2,QTC2,QX,QXC,QXC9,QXS2,QXU,QX2,QX26,QX4,Q1,RX,RX4,R1,SG24,SJC1,SJC5,SMA7,SMJ,SMW2,SSX4,SX,SX4,S1,TX,TX2,TX26,TX4,UX,UXU,VAX4,VED1,VEE1,VEX,VMS4,VPR4,VSX,VSX1,VX,VXU,VX4,WKT2,WME2,W1
			1	-	-	-	-----	QWA4,QX7,SM12,SM14,SSX2,SWX2,SWX4,SXS4,SX7,VED6,VEX7,VMT,VX7,WKD6,WKT4,WKT6
4	16510-ZE1-000	GOVERNOR ASSY. ....	1	1	1	1		
5	16511-ZE1-000	WEIGHT, GOVERNOR .....	2	2	2	2		
6	16512-ZE1-000	HOLDER, GOVERNOR WEIGHT .....	1	1	1	1		
7	16513-ZE1-000	PIN, GOVERNOR WEIGHT .....	2	2	2	2		
8	16531-ZE1-000	SLIDER, GOVERNOR .....	1	1	1	1		
9	16541-ZE1-000	SHAFT, GOVERNOR ARM .....	1	1	1	1		
10	68326-ZB2-000	RUBBER, FR. BOTTOM .....	2	-	-	-	-----	VS,VSX,VSX1,VS1
11	68327-ZB2-000	RUBBER, RR. BOTTOM .....	2	-	-	-	-----	VS,VSX,VSX1,VS1
12	90131-ZE1-000	BOLT, DRAIN PLUG .....	2	2	2	2		
13	90451-ZE1-000	WASHER, THRUST, 6MM .....	1	(1)	1	1		
14	90601-ZE1-000	WASHER, DRAIN PLUG, 10.2MM ..	2	2	2	2		
15	90602-ZE1-000	CLIP, GOVERNOR HOLDER .....	1	1	1	1		
16	91001-878-003	BEARING, RADIAL BALL, 62/22 ..	1	(1)	1	1		



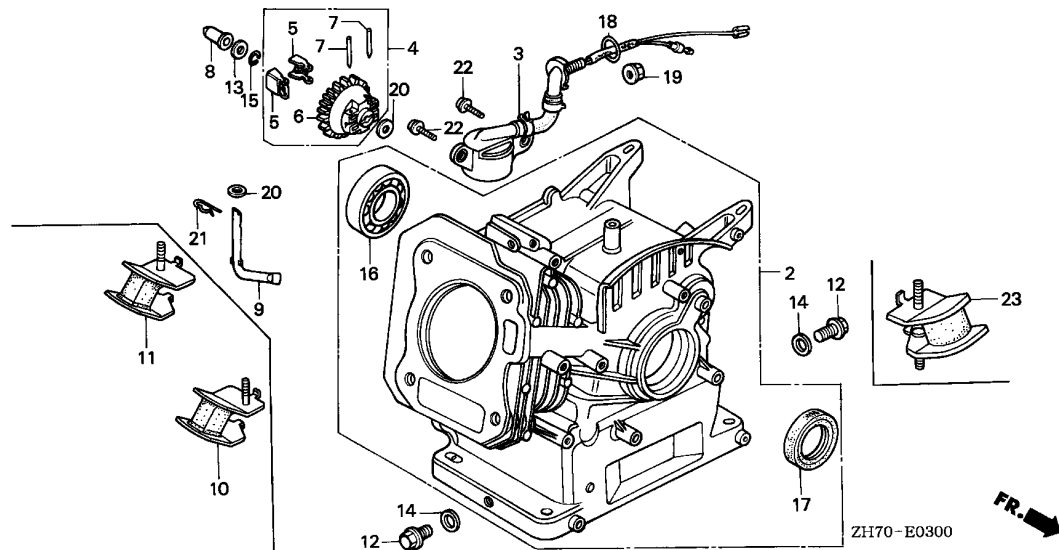

Ref. No.	Part No.	Description	Reqd. QTY				Serial No.	Parts catalogue code
			(1)	(2)	(3)	(4)		
17	91202-ZE6-003	OIL SEAL, 22X35X6 .....	1	(1)	1	-	-----	EN,ET,ETX,HH,HXQ,LDB1,LDB3,LD4,LE,LEH4,LJT,LTA,LW2,LX26,PH,PM,PM2,QAA2,QA26,QBU2,QE,QEH,QH2,QPU,QSJ,QTC2,QXC,QXG,QXG2,QXQ,QXS,RH,SAD2,SDB1,SDB3,SKJ,SN,SSK2,SW2,TH,UH,UIH,UX,U1,VA,VAX4,VH,VS,VS1,V1,WDJ,WJP1
			1	(1)	-	-	4205163	AR,DKR,DS,HHQ4,HTF2,HT2,HX,HXU,HX2,HX26,HX4,H1,KR,KRA4,KRF4,KRS4,KRT,KRT4,KRT6,LAJ4,LD,LH,LHQ4,LJ,LJC,LJD2,LJS,LSJ,LSJ4,LTJ,LTK1,LTR,LX,LXU,LX2,LX4,L1,PX,PX2,QA,QA2,QB26,QD,QH,QHQ4,QH26,QJG2,QLL,QM,QMA4,QMA8,QME4,QMX2,QT,QWA4,QX,QXC9,QXS2,QXU,QX2,QX26,QX4,QX7,Q1,RD,RD4,RHC,RHQ4,RX,RX4,R1,SAJ,SAJ4,SCJ,SD,SD16,SD4,SE,SG24,SH,SHQ4,SJ,SJC,SJC1,SJC5,SJD2,SKR,SMA7,SMJ,SMW2,SM11,SM12,SM14,SSK1,SSK3,SSX2,SSX4,STP,STS,SWX2,SWX4,SX,SXS4,SX4,SX7,S1,TX,TX2,TX26,TX4,UXU,VED,VED1,VED6,VEE1,VEK,VET,VEX,VEX7,VMS4,VMT,VPR4,VSX,VSX1,VX,VXU,VX4,VX7,WDA6,WD12,WJ,WJP,WKD6,WKT2,WKT4,WKT6,WMA3,WME2,WME4,WM1,W1
	91202-ZE6-013	.....	-	-	-	1	-----	
			1	(1)	-	-	4205164	AR,DKR,DS,HHQ4,HTF2,HT2,HX,HXU,HX2,HX26,HX4,H1,KR,KRA4,KRF4,KRS4,KRT,KRT4,KRT6,LAJ4,LD,LH,LHQ4,LJ,LJC,LJD2,LJS,LSJ,LSJ4,LTJ,LTK1,LTR,LX,LXU,LX2,LX4,L1,PX,PX2,QA,QA2,QB26,QD,QH,QHQ4,QH26,QJG2,QLL,QM,QMA4,QMA8,QME4,QMX2,QT,QWA4,QX,QXC9,QXS2,QXU,QX2,QX26,QX4,QX7,Q1,RD,RD4,RHC,RHQ4,RX,RX4,R1,SAJ,SAJ4,SCJ,SD,SD16,SD4,SE,SG24,SH,SHQ4,SJ,SJC,SJC1,SJC5,SJD2,SKR,SMA7,SMJ,SMW2,SM11,SM12,SM14,SSK1,SSK3,SSX2,SSX4,STP,STS,SWX2,SWX4,SX,SXS4,SX4,SX7,S1,TX,TX2,TX26,TX4,UXU,VED,VED1,VED6,VEE1,VEK,VET,VEX,VEX7,VMS4,VMT,VPR4,VSX,VSX1,VX,VXU,VX4,VX7,WDA6,WD12,WJ,WJP,WKD6,WKT2,WKT4,WKT6,WMA3,WME2,WME4,WM1,W1
			1	-	1	-	-----	LTS,QIH1,WIH1

Ref. No.	Part No.	Description	Reqd. QTY				Serial No.	Parts catalogue code
			(1)	GX120K1 (2)	(3)	(4)		
18	91353-671-004	O-RING, 14MM(NOK)	1	-	-	-	ETX,HTF2,HX,HXQ,HXU,HX2,HX26,HX4,LJC,LTA,LX,LXU,LX2,LX26,LX4 PX,PX2,QBU2,QJW1,QLL,QMA8,QMH,QMX2,QTC2,QWA4,QX,QXC,QXC9,QXG QXQ,QXS,QXS2,QXU,QX2,QX26,QX4,QX7,RX,RX4,SAD2,SG24,SJC1,SJC5 SMA7,SMJ,SMW2,SM12,SM14,SSX2,SSX4,SWX2,SWX4,SX,SXS4, SX4, SX7, TX TX2, TX26, TX4, UX, UXU, VA, VAX4, VED1, VED6, VEE1, VEX, VEX7, VMS4, VMT VPR4, VSX, VSX1, VX, VXU, VX4, VX7, WKD6, WKT2, WKT4, WKT6, WME2	
			1	-	-	-	2564424 QXG2	
			-	(1)	-	-		
19	94050-10000	NUT, FLANGE, 10MM	1	-	-	-	ETX,HTF2,HX,HXQ,HXU,HX2,HX26,HX4,LJC,LTA,LX,LXU,LX2,LX26,LX4 PX,PX2,QBU2,QJW1,QLL,QMA8,QMH,QMX2,QTC2,QWA4,QX,QXC,QXC9,QXG QXQ,QXS,QXS2,QXU,QX2,QX26,QX4,QX7,RX,RX4,SAD2,SG24,SJC1,SJC5 SMA7,SMJ,SMW2,SM12,SM14,SSX2,SSX4,SWX2,SWX4,SX,SXS4, SX4, SX7, TX TX2, TX26, TX4, UX, UXU, VA, VAX4, VED1, VED6, VEE1, VEX, VEX7, VMS4, VMT VPR4, VSX, VSX1, VX, VXU, VX4, VX7, WKD6, WKT2, WKT4, WKT6, WME2	
			1	-	-	-	2564424 QXG2	
			-	(1)	-	-		
20	94101-06800	WASHER, PLAIN, 6MM	2	-	-	-	AR,DKR,DS,EN,ET,ETX,HH,HHQ4,HTF2,HT2,HX,HXQ,HXU,HX2,HX26,HX4 KR,KRA4,KRF4,KRS4,KRT,KRT4,KRT6,LAJ4,LD,LDB1,LDB3,LD4,LE,LEH4 LH,LHQ4,LJ,LJC,LJD2,LJS,LJT,LSJ,LSJ4,LTA,LTJ,LTK1,LTR,LTS,LW2 LX,LXU,LX2,LX26,LX4,PH,PM,PM2,PX,PX2,QA,QAA2,QA2,QA26,QBU2,QD QE,QE,QH,QHQ4,QH2,QH26,QJG2,QJW1,QLL,QM,QMA4,QMA8,QME4,QMH QMX2,QPU,QSJ,QT,QTC2,QWA4,QX,QXC,QXC9,QXG,QXG2,QXQ,QXS,QXS2 QXU,QX2,QX26,QX4,QX7,RD,RD4,RH,RHC,RHQ4,RX,RX4,SAD2,SAJ,SAJ4 SCJ,SD,SDB1,SDB3,SD16,SD4,SE,SG24,SH,SHQ4,SJ,SJC,SJC1,SJC5 SJD2,SKJ,SKR,SMA7,SMJ,SMW2,SM11,SM12,SM14,SN,SSK1,SSK2,SSK3 SSX2,SSX4,STP,STS,SWX2,SWX4,SW2,SX,SXS4, SX4, SX7, TH, TX, TX2, TX26 TX4,UH,UX,UXU,VA,VAX4,VED,VED1,VED6,VEE1,VEK,VET,VEX,VEX7,VH VMS4,VMT,VPR4,VS,VSX,VSX1,VS1,VX,VXU,VX4,VX7,WDA6,WDJ,WD12,WJ WJP,WJP1,WJ1,WKD6,WKT2,WKT4,WKT6,WMA3,WME2,WME4,WM1	
			2	-	-	-	3323432 QB26	
			-	2	2	2		
21	94251-08000	PIN, LOCK, 8MM	1	1	1	1		
22	95701-06012-00	BOLT, FLANGE, 6X12	2	-	-	-	ETX,HTF2,HX,HXQ,HXU,HX2,HX26,HX4,LJC,LTA,LX,LXU,LX2,LX26,LX4 PX,PX2,QBU2,QJW1,QLL,QMA8,QMH,QMX2,QTC2,QWA4,QX,QXC,QXC9,QXG QXQ,QXS,QXS2,QXU,QX2,QX26,QX4,QX7,RX,RX4,SAD2,SG24,SJC1,SJC5 SMA7,SMJ,SMW2,SM12,SM14,SSX2,SSX4,SWX2,SWX4,SX,SXS4, SX4, SX7, TX TX2, TX26, TX4, UX, UXU, VA, VAX4, VED1, VED6, VEE1, VEX, VEX7, VMS4, VMT VPR4, VSX, VSX1, VX, VXU, VX4, VX7, WKD6, WKT2, WKT4, WKT6, WME2	
			2	-	-	-	2564424 QXG2	
			-	(2)	-	-		
23	68328-ZB2-000	RUBBER, BOTTOM	4	-	-	-	VET	



E-6

CRANKCASE COVER

E14

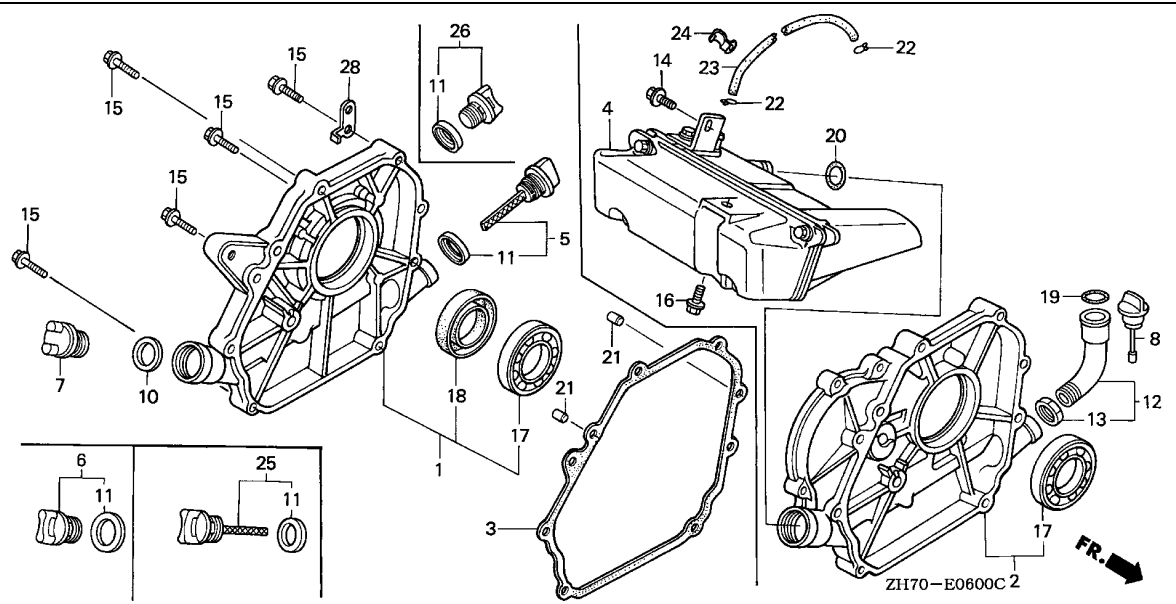

Ref. No.	L.O.N.	(Relative ref. Number) Description	F.R.T.
1		(2)	
1	1101F1	COVER, CRANKCASE .....	0.3
3	1101E9	PACKING, CASE COVER .....	0.3
4	1171A3	TANK, OIL .....	0.2
12	1101B9	EXTENSION, OIL FILLER AND/OR PACKING, EXTENSION OIL FILLER .....	0.1
17	1101A6	BEARING, CRANKSHAFT :REAR .....	0.4
18	1101E5	OIL SEAL, CRANKSHAFT :REAR .....	0.3
23	1171A7	TUBE, OIL TANK .....	0.1

Ref. No.	Part No.	Description	Reqd. QTY				Serial No.	Parts catalogue code
			(1)	(2)	(3)	(4)		
1	11300-ZE0-000	COVER ASSY., CRANKCASE .....	1	1	-	-	4223185	RD, RD4, RHC, RHQ4, RX, RX4, R1, SJD2, SWX2, SWX4, VEK RH, SN, SW2
	11300-ZE0-632	.....	1	1	-	-	2902021	EN, ET, ETX, HH, HHQ4, HTF2, HX, HXQ, HX2, HX26, HX4, H1, QSJ, SAD2, SAJ, SCJ SD, SDB1, SDB3, SD16, SD4, SE, SG24, SH, SHQ4, SJ, SJC, SJC1, SKJ, SMA7, SMJ SMW2, SSK1, SSK2, SSK3, SSX4, STP, STS, SX, SX4, S1, VED, VED1, VET, VS, VSX VSX1, VS1, WDJ, WJ, WJP, WJP1, WKT2, WMA3, WME2, W1
	11300-ZE0-633	.....	1	1	-	-	2902022	4223185 HHQ4, HTF2, HX, HX2, HX26, HX4, H1, SAJ, SCJ, SD, SD16, SD4, SE, SG24, SH SHQ4, SJ, SJC, SJC1, SMA7, SMJ, SMW2, SSK1, SSK3, SSX4, STP, STS, SX, SX4 S1, VED, VED1, VET, VSX, VSX1, WJ, WJP, WKT2, WMA3, WME2, W1 WJ1
			1	-	-	-	2902022	----- EN, ET, ETX, HH, HXQ, QSJ, SAD2, SDB1, SDB3, SKJ, SSK2, VS, VS1, WDJ, WJP1
			1	-	-	-	4223185	----- HT2, HXU, SAJ4, SJC5, SKR, SM11, SM12, SM14, SSSX2, SXS4, SX7, VED6, VEE1 VMT, WDA6, WD12, WKD6, WKT4, WKT6, WME4, WM1
	11300-ZE0-640	.....	1	1	1	-	-----	PH, PM, PM2, QAA2, QA26, QBU2, QE, QEH, QH2, QJW1, QMH, QPU, QTC2, QXC, QXG QXG2, QXQ, QXS, TH, UH, UIH, UX, U1, VA, VAX4, VH, V1
			1	1	-	-	4228308	----- PX, PX2, QA, QA2, QB26, QD, QH, QHQ4, QH26, QJG2, QLL, QM, QMA4, QMA8, QME4 QMX2, QT, QWA4, QX, QXC9, QXS2, QXU, QX2, QX26, QX4, QX7, Q1, TX, TX2, TX26 TX4, UXU, VEX, VEX7, VMS4, VPR4, VX, VXU, VX4, VX7
			-	-	-	1	-----	
	11300-ZE0-010	.....	1	1	-	-	4223186	----- RD, RD4, RHC, RHQ4, RX, RX4, R1, SJD2, SWX2, SWX4, VEK
	11300-ZE0-634	.....	1	1	-	-	4223186	----- HHQ4, HTF2, HT2, HX, HXU, HX2, HX26, HX4, H1, SAJ, SAJ4, SCJ, SD, SD16, SD4 SE, SG24, SH, SHQ4, SJ, SJC, SJC1, SJC5, SKR, SMA7, SMJ, SMW2, SM11, SM12 SM14, SSK1, SSK3, SSX2, SSX4, STP, STS, SX, SXS4, SX4, SX7, S1, VED, VED1 VED6, VEE1, VET, VMT, VSX, VSX1, WDA6, WD12, WJ, WJP, WKD6, WKT2, WKT4 WKT6, WMA3, WME2, WME4, WM1, W1
			-	-	1	-	-----	WIH1

2

Ref. No.	Part No.	Description	Reqd. QTY				Serial No.	Parts catalogue code
			(1)	GX120K1 (2)	(3)	(4)		
(1)	11300-ZE0-641	COVER ASSY., CRANKCASE .....	1	1	-	-	4228309 -----	PX,PX2,QA,QA2,QB26,QD,QH,QHQ4,QH26,QJG2,QLL,QM,QMA4,QMA8,QME4,QMX2,QT,QWA4,QX,QXC9,QXS2,QXU,QX2,QX26,QX4,QX7,Q1,TX,TX2,TX26,UXU,VEX,VEX7,VMS4,VPR4,VX,VXU,VX4,VX7
			-	-	1	-	-----	QIH1
2	11300-ZE0-612	COVER ASSY., CRANKCASE .....	1	1	-	-	-----	DS,LD,LE,LH,LJ,LW2,LX,LXU,L1
	11300-ZE0-613	.....	1	-	-	-	-----	LAJ4,LDB1,LDB3,LD4,LEH4,LHQ4,LJC,LJD2,LJS,LJT,LSJ,LSJ4,LTA,LTJ,LTK1,LTR,LTS,LX2,LX26,LX4
	11300-ZK7-V00	.....	1	-	-	-	-----	AR,DKR,KR,KRA4,KRF4,KRS4
	11300-ZK7-V20	.....	1	-	-	-	-----	KRT,KRT4
	11300-ZK7-W20	.....	1	-	-	-	-----	KRT6
3	11381-ZE0-000	PACKING, CASE COVER .....	1	-	-	-	-----	HH,HX,HXU,LD,LE,LH,LX,LXU,PH,PX,QD,QE,QH,QX,QXU,RD,RH,RX,SD,SE,SH,SX,TH,UH,UX,UXU,VA,VED,VED1,VH,VS,VSX,VXU
			1	-	-	-	-----	2272434 DS,EN,ET,ETX,LJ,LTA,QSJ,SJ,SKJ,SMJ,STS,VET,WJ
			-	1	-	-	-----	2272434
	11381-ZH7-800	.....	1	-	-	-	-----	HHQ4,HTF2,HT2,HX,HXQ,HX2,HX26,HX4,KRT,KRT4,LAJ4,LD,LDB1,LDB3,LD4,LEH4,LHQ4,LJC,LJD2,LJS,LJT,LSJ,LSJ4,LTJ,LTK1,LTR,LTS,LW2,LX,LX2,LX26,LX4,PH,PM,PM2,PX,PX2,QA,QAA2,QA2,QA26,QBU2,QB26,QD,QEH,QHQ4,QH2,QH26,QJG2,QJW1,QLL,QM,QMA4,QMA8,QME4,QMH,QMX2,QPU,QT,QTC2,QWA4,QX,QXC,QXC9,QXG,QXG2,QXQ,QXS,QXS2,QX2,QX26,QX4,QX7,RD,RD4,RHC,RHQ4,RX,RX4,SAD2,SAJ,SAJ4,SCJ,SD,SDB1,SDB3,SD16,SD4,SG24,SHQ4,SJC,SJC1,SJC5,SJD2,SKR,SMA7,SMW2,SM11,SM12,SM14,SN,SSK1,SSK2,SSK3,SSX2,SSX4,STP,SWX2,SWX4,SW2,SX,SXS4,SX4,SX7,TH,TX,TX2,TX26,TX4,UH,UX,VAX4,VED6,VEE1,VEK,VEX,VEX7,VH,VMS4,VMT,VPR4,VSX1,VS1,VX,VX4,VX7,WDA6,WJ,WD12,WJP,WJP1,WJ1,WKD6,WKT2,WKT4,WKT6,WMA3,WME2,WME4,WM1
			1	-	-	-	-----	2272435 DS,EN,ET,ETX,LJ,LTA,QSJ,SJ,SKJ,SMJ,STS,VET,WJ
			-	1	-	-	-----	2272435
			-	-	1	1	-----	
	11381-ZK7-V00	.....	1	-	-	-	-----	AR,DKR,KR,KRA4,KRF4,KRS4
	11381-ZK7-W20	.....	1	-	-	-	-----	KRT6
4	15500-ZK7-V00	TANK ASSY., OIL .....	1	-	-	-	-----	AR,DKR,KR,KRA4,KRF4,KRS4,KRT,KRT4,KRT6
5	15600-ZE1-000	CAP ASSY., OIL FILLER (GRAY) .....	1	1	-	-	-----	2354642 EN,ET,ETX,HH,H1,LD,LE,LH,LX,L1,PH,PX,QD,QE,QEH,QH,Q1,RD,RH,RHC,RX,R1,SD,SE,SH,SX,S1,TH,UH,UX,VA,VED,VED1,VEX,VH,VS,VSX,VSX1,VS1,VX,V1,W1
			1	-	-	-	-----	2345619 QPU
			1	-	-	-	-----	2354519 HX,HXQ,HX2,LX2,QA,QA2,QH2,QX,QXC,QXG,QXG2,QXQ,QXS,QXS2,QX2,TX,TX2
			1	-	-	-	-----	2899521 DS,LJ,LTJ,QSJ,SJ,SKJ,SMJ,STS,VET,WJ
			-	1	-	-	-----	U1
	15600-ZE1-003	.....	1	1	-	-	-----	2354643 EN,ET,ETX,HH,H1,LD,LE,LH,LX,L1,PH,PX,QD,QE,QEH,QH,Q1,RD,RH,RHC,RX,R1,SD,SE,SH,SX,S1,TH,UH,UX,VA,VED,VED1,VEX,VH,VS,VSX,VSX1,VS1,VX,V1,W1
			1	-	-	-	-----	AR,DKR,HHQ4,HTF2,HT2,HXU,HX26,HX4,KR,KRA4,KRF4,KRS4,KRT,KRT4,KRT6,LAJ4,LDB1,LDB3,LD4,LEH4,LHQ4,LJC,LJS,LJT,LSJ,LSJ4,LTK1,LTR,LTS,LXU,LX26,LX4,PX2,QAA2,QA26,QBU2,QB26,QHQ4,QH26,QJG2,QJW1,QLL,QMA4,QMA8,QME4,QMH,QMX2,QTC2,QWA4,QXC9,QXU,QX26,QX4,QX7,RD4,RHQ4,RX4,SAD2,SAJ,SAJ4,SCJ,SDB1,SDB3,SD16,SD4,SG24,SHQ4,SJC,SJC1,SJC5,SKR,SMA7,SMW2,SM11,SM12,SM14,SSK1,SSK2,SSK3,SSX2,SSX4,STP,SXS4,SX4,SX7,TX26,TX4,UXU,VAX4,VED6,VEE1,VEK,VEX7,VMS4,VMT,VPR4,VXU,VX4,VX7,WDA6,WJ,WD12,WJP,WJP1,WJ1,WKD6,WKT2,WKT4,WKT6,WMA3,WME2,WME4,WM1
			1	-	-	-	-----	2345620 QPU
			1	-	-	-	-----	2354520 HX,HXQ,HX2,LX2,QA,QA2,QH2,QX,QXC,QXG,QXG2,QXQ,QXS,QXS2,QX2,TX,TX2
			1	-	-	-	-----	2899522 DS,LJ,LTJ,QSJ,SJ,SKJ,SMJ,STS,VET,WJ
			-	-	-	1	-----	
	15600-ZF0-000	CAP ASSY., OIL FILLER .....	1	-	-	-	-----	2354642 LW2,PM,PM2,QM,QT,SN,SW2





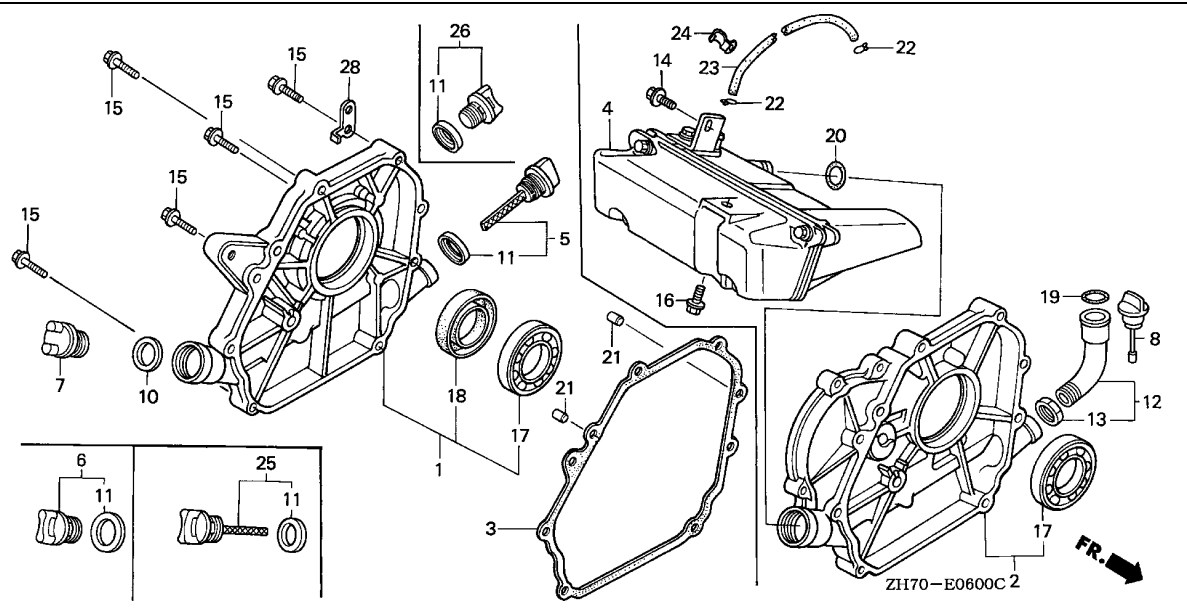

Ref. No.	Part No.	Description	Reqd. QTY				Serial No.	Parts catalogue code
			(1)	(2)	(3)	(4)		
(5)	15600-ZF0-003	CAP ASSY., OIL FILLER .....	1	-	-	-	2354643	LW2,PM,PM2,QM,QT,SN,SW2
	15600-ZK7-U21	CAP ASSY., OIL FILLER (YELLOW)	1	-	-	-		LJD2,SJD2
	15600-ZE1-003	CAP ASSY., OIL FILLER (GRAY)	1	-	-	-		LJD2,SJD2
6	15600-ZG4-003	CAP ASSY., OIL FILLER .....	1	1	-	-	2354643	EN,ET,ETX,HH,H1,LD,LE,LH,LW2,LX,L1,PH,PM,PM2,PX,QD,QE,QEH,QH,QM,QT,Q1,RD,RH,RHC,RX,R1,SD,SE,SH,SN,SW2,SX,S1,TH,UH,UX,VA,VED,VED1,VEX,VH,VS,VSX,VSX1,VS1,VX,V1,W1
			1	-	-	-		HHQ4,HTF2,HT2,HXU,HX26,HX4,LAJ4,LDB1,LDB3,LD4,LEH4,LHQ4,LJC,LJD2,LJS,LJT,LSJ,LSJ4,LTK1,LTR,LTS,LXU,LX26,LX4,PX2,QAA2,QA26,QBU2,QB26,QHQ4,QH26,QJG2,QJW1,QLL,QMA4,QMA8,QME4,QMH,QMX2,QTC2,QWA4,QXC9,QXU,QX26,QX4,QX7,RD4,RHQ4,RX4,SAD2,SAJ,SAJ4,SCJ,SDB1,SDB3,SD16,SD4,SG24,SHQ4,SJC,SJC1,SJC5,SJD2,SKR,SMA7,SMW2,SM11,SM12,SM14,SSK1,SSK2,SSK3,SSX2,SSX4,STP,SXS4,SX4, SX7, TX26, TX4,UXU,VAX4,VED6,VEE1,VEK,VEX7,VMS4,VMT,VPR4,VXU,VX4,VX7,WDA6,WDJ,WD12,WJP,WJP1,WJ1,WKD6,WKT2,WKT4,WKT6,WMA3,WME2,WME4,WM1
			1	-	-	-	2345620	QPU
			1	-	-	-	2354520	DS,HX,HXQ,HX2,LJ,LTA,LTJ,LX2,QA,QA2,QH2,QSJ,QX,QXC,QXG,QXG2,QXQ,QXS,QXS2,QX2,SJ,SKJ,STS, TX, TX2, VET, WJ
7	15620-ZG4-910	CAP, OIL FILLER .....	1	1	-	-	2354642	EN,ET,ETX,HH,H1,LD,LE,LH,LW2,LX,L1,PH,PM,PM2,PX,QD,QE,QEH,QH,QM,QT,Q1,RD,RH,RHC,RX,R1,SD,SE,SH,SN,SW2,SX,S1,TH,UH,UX,VA,VED,VED1,VEX,VH,VS,VSX,VSX1,VS1,VX,V1,W1
			1	-	-	-	2345619	QPU
			1	-	-	-	2354519	DS,HX,HXQ,HX2,LJ,LTA,LTJ,LX2,QA,QA2,QH2,QSJ,QX,QXC,QXG,QXG2,QXQ,QXS,QXS2,QX2,SJ,SKJ,STS, TX, TX2, VET, WJ
8	15620-ZH7-V90	GAUGE COMP., OIL LEVEL (TAC)	1	-	-	-		U1
			1	-	-	-		LTA

2

Ref. No.	Part No.	Description	Reqd. QTY				Serial No.	Parts catalogue code
			(1)	GX120K1 (2)	(3)	(4)		
10	15621-896-010	PACKING, OIL FILLER CAP .....	1	1	-	-	2354642 EN,ET,ETX,HH,H1,LD,LE,LH,LW2,LX,L1,PH,PM,PM2,PX,QD,QE,QEH,QH QM,QT,Q1,RD,RH,RHC,RX,R1,SD,SE,SH,SN,SW2,SX,S1,TH,UH,UX,VA,VED VED1,VEX,VH,VS,VSX,VSX1,VS1,VX,V1,W1	
			1	-	-	-	2345619 QPU	
			1	-	-	-	2354519 DS,HX,HXQ,HX2,LJ,LTA,LTJ,LX2,QA,QA2,QH2,QSJ,QX,QXC,QXG,QXG2 QXQ,QXS,QXS2,QX2,SJ,SKJ,STS,TX,TX2,VET,WJ	
			-	1	-	-	U1	
11	15625-ZE1-000	PACKING, OIL FILLER CAP .....	1	1	-	-	2354642 EN,ET,ETX,HH,H1,LD,LE,LH,LW2,LX,L1,PH,PM,PM2,PX,QD,QE,QEH,QH QM,QT,Q1,RD,RH,RHC,RX,R1,SD,SE,SH,SN,SW2,SX,S1,TH,UH,UX,VA,VED VED1,VEX,VH,VS,VSX,VSX1,VS1,VX,V1,W1	
			1	-	-	-	2345619 QPU	
			1	-	-	-	2354519 DS,HX,HXQ,HX2,LJ,LTJ,LX2,QA,QA2,QH2,QSJ,QX,QXC,QXG,QXG2,QXQ QXS,QXS2,QX2,SJ,SKJ,STS,TX,TX2,VET,WJ	
			2	-	-	-	2354519 SMJ	
			-	1	-	-	U1	
	15625-ZE1-003	.....	1	-	-	-	AR,DKR,KR,KRA4,KRF4,KRS4,KRT,KRT4,KRT6	
			2	2	-	-	2354643 EN,ET,ETX,HH,H1,LD,LE,LH,LW2,LX,L1,PH,PM,PM2,PX,QD,QE,QEH,QH QM,QT,Q1,RD,RH,RHC,RX,R1,SD,SE,SH,SN,SW2,SX,S1,TH,UH,UX,VA,VED VED1,VEX,VH,VS,VSX,VSX1,VS1,VX,V1,W1	
			2	-	-	-	HHQ4,HTF2,HT2,HXU,HX26,HX4,LAJ4,LDB1,LDB3,LD4,LEH4,LHQ4,LJC LJD2,LJS,LJT,LSJ,LSJ4,LTK1,LTR,LTS,LXU,LX26,LX4,PX2,QAA2,QA26 QBU2,QB26,QHQ4,QH26,QJG2,QJW1,QLL,QMA4,QMA8,QME4,QMH,QMX2,QTC2 QWA4,QXC9,QXU,QX26,QX4,QX7,RD4,RHQ4,RX4,SAD2,SAJ,SAJ4,SCJ,SDB1 SDB3,SD16,SD4,SG24,SHQ4,SJC,SJC1,SJC5,SJD2,SKR,SMA7,SMW2,SM11 SM12,SM14,SSK1,SSK2,SSK3,SSX2,SSX4,STP,SWX2,SWX4,SXS4,SX4,SX7 TX26,UXU,VAX4,VED6,VEE1,VEK,VEX7,VMS4,VMT,VPR4,VXU,VX4,VX7 WDA6,WDJ,WD12,WJP,WJP1,WJ1,WKD6,WKT2,WKT4,WKT6,WMA3,WME2,WME4 WM1	
			2	-	-	-	2345620 QPU	
			2	-	-	-	2354520 DS,HX,HXQ,HX2,LJ,LTA,LTJ,LX2,QA,QA2,QH2,QSJ,QX,QXC,QXG,QXG2 QXQ,QXS,QXS2,QX2,SJ,SKJ,SMJ,STS,TX,TX2,VET,WJ	
			-	-	2	2		
12	15632-883-630	PIPE COMP., OIL .....	1	-	-	-	LTA	
13	90011-883-630	NUT, OIL FILLER .....	1	-	-	-	LTA	
14	90014-952-000	BOLT, FLANGE, 6X14(CT200) ...	1	-	-	-	AR,DKR,KR,KRA4,KRF4,KRS4,KRT,KRT4,KRT6	
15	90015-883-000	BOLT, FLANGE, 6X28 .....	7	7	7	7		
16	90029-888-000	BOLT, FLANGE, 6X16(CT200) ...	1	-	-	-	AR,DKR,KR,KRA4,KRF4,KRS4,KRT,KRT4,KRT6	
17	91001-878-003	BEARING, RADIAL BALL, 62/22 .	1	1	1	1		
18	91203-ZE0-003	OIL SEAL, 22X41X6 .....	1	1	1	-	EN,ET,ETX,HH,HXQ,PH,PM,PM2,QAA2,QA26,QBU2,QE,QEH,QH2,QJW1,QMH QPU,QSJ,QTC2,QXC,QXG,QXG2,QXQ,QXS,RH,SAD2,SDB1,SDB3,SKJ,SN SSK2,SW2,TH,UH,UIH,UX,U1,VA,VAX4,VH,VS,VS1,V1,WDJ,WJP1,WJ1	
			1	1	-	-	4223185 HHQ4,HTF2,HT2,HX,HXU,HX2,HX26,HX4,H1,RD,RD4,RHC,RHQ4,RX,RX4,R1 SAJ,SAJ4,SCJ,SD,SD16,SD4,SE,SG24,SH,SHQ4,SJ,SJC,SJC1,SJC5,SJD2 SKR,SMA7,SMJ,SMW2,SM11,SM12,SM14,SSK1,SSK3,SSX2,SSX4,STP,STS SWX2,SWX4,SX,SXS4,SX4,SX7,S1,VED,VED1,VED6,VEE1,VEK,VET,VMT VSX,VSX1,WDA6,WD12,WJ,WJP,WKD6,WKT2,WKT4,WKT6,WMA3,WME2,WME4 WM1,W1	
			1	1	-	-	4228308 PX,PX2,QA,QA2,QB26,QD,QH,QHQ4,QH26,QJG2,QLL,QM,QMA4,QMA8,QME4 QMX2,QT,QWA4,QX,QXC9,QXS2,QXU,QX2,QX26,QX4,QX7,Q1,TX,TX2,TX26 TX4,UXU,VEX,VEX7,VMS4,VPR4,VX,VXU,VX4,VX7	
			-	-	-	1		



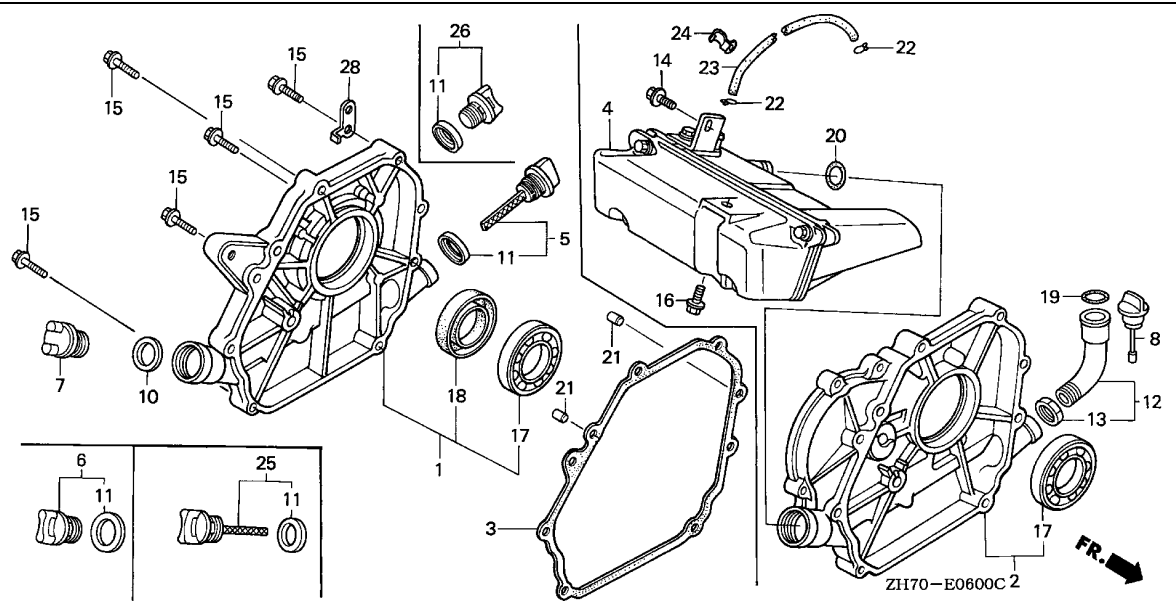

Ref. No.	Part No.	Description	Reqd. QTY				Serial No.	Parts catalogue code
			(1)	(2)	(3)	(4)		
18)	91203-ZE0-013	OIL SEAL, 22X41X6 .....	1	1	-	-	4223186	HHQ4,HTF2,HT2,HX,HXU,HX2,HX26,HX4,H1,RD,RD4,RHC,RHQ4,RX,RX4,R1SAJ,SAJ4,SCJ,SD,SD16,SD4,SE,SG24,SH,SHQ4,SJ,SJC,SJC1,SJC5,SJD2,SKR,SMA7,SMJ,SMW2,SM11,SM12,SM14,SSK1,SSK3,SSX2,SSX4,STP,STS,SWX2,SWX4,SX,SXS4,SX4,SX7,S1,VED,VED1,VED6,VEE1,VEK,VET,VMT,VSX,VSX1,WDA6,WD12,WJ,WJP,WKD6,WKT2,WKT4,WKT6,WMA3,WME2,WME4,WM1,W1
			1	1	-	-	4228309	PX,PX2,QA,QA2,QB26,QD,QH,QHQ4,QH26,QJG2,QLL,QM,QMA4,QMA8,QME4,QMX2,QT,QWA4,QX,QXC9,QXS2,QXU,QX2,QX26,QX4,QX7,Q1,TX,TX2,TX26,UXU,VEX,VEX7,VMS4,VPR4,VX,VXU,VX4,VX7
	19	91303-800-000	O-RING, 16MM .....	-	-	1	-	QIH1,WIH1
	20	91304-MJ0-003	O-RING, 15.8X2.4(SHOWA) .....	1	-	-	-	LTA
	21	94301-08140	DOWEL PIN, 8X14 .....	2	-	-	-	AR,DKR,KR,KRA4,KRF4,KRS4,KRT,KRT4,KRT6
				-	2	2	2	DS,EN,ET,ETX,HH,HHQ4,HTF2,HT2,HX,HXQ,HXU,HX2,HX26,HX4,KRT,KRT4,KRT6,LAJ4,LD,LDB1,LDB3,LD4,LE,LEH4,LH,LHQ4,LJ,LJC,LJD2,LJS,LJT,LSJ,LSJ4,LTA,LTJ,LTK1,LTR,LTS,LW2,LX,LXU,LX2,LX26,LX4,PH,PM,PM2,PX,PX2,QA,QAA2,QA2,QA26,QBU2,QB26,QD,QE,QEH,QH,QHQ4,QH2,QH26,QJG2,QJW1,QLL,QM,QMA4,QMA8,QME4,QMH,QMX2,QPU,QSJ,QT,QTC2,QWA4,QX,QXC,QXC9,QXG,QXG2,QXQ,QXS,QXS2,QXU,QX2,QX26,QX4,QX7,RD,RD4,RH,RHC,RHQ4,RX,RX4,SAD2,SAJ,SAJ4,SCJ,SD,SDB1,SDB3,SD16,SD4,SE,SG24,SH,SHQ4,SJ,SJC,SJC1,SJC5,SJD2,SKJ,SKR,SMA7,SMJ,SMW2,SM11,SM12,SM14,SN,SSK1,SSK2,SSK3,SSX2,SSX4,STP,STS,SWX2,SWX4,SW2,SX,SXS4,SX4,SX7,TH,TX,TX2,TX26,TX4,UH,UX,UXU,VA,VAX4,VED,VED1,VED6,VEE1,VEK,VET,VEX,VEX7,VH,VMS4,VMT,VPR4,VS,VSX,VSX1,VS1,VX,VXU,VX4,VX7,WDA6,WDJ,WD12,WJ,WJP,WJP1,WJ1,WKD6,WKT2,WKT4,WKT6,WMA3,WME2,WME4,WM1
		94303-08140	.....	2	-	-	-	AR,DKR,KR,KRA4,KRF4,KRS4
	22	95002-02070	CLIP, TUBE (B7) .....	2	-	-	-	AR,DKR,KR,KRA4,KRF4,KRS4,KRT,KRT4,KRT6

E-6

CRANKCASE COVER

F 3

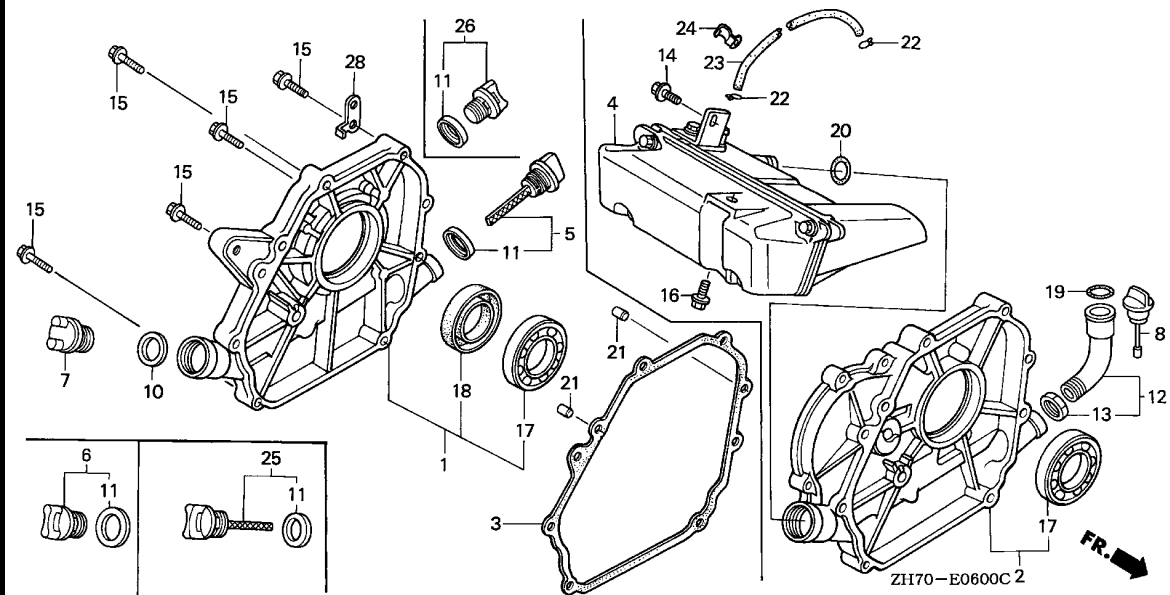

Ref. No.	Part No.	Description	Reqd. QTY				Serial No.	Parts catalogue code
			(1)	(2)	(3)	(4)		
			GX120K1					
23	95005-35150-10	TUBE, 3.5X150(95005-35001-10M)	1	-	-	-	AR,DKR,KR,KRA4,KRF4,KRS4,KRT,KRT4,KRT6	
24	35210-MA6-000	CLAMP, SWITCH CORD	1	-	-	-	KRT4	
25	15600-ZE1-000	CAP ASSY., OIL FILLER (GRAY)	1	-	-	-	2899521 SMJ	
	15600-ZE1-003		1	-	-	-	SWX2,SWX4	
			1	-	-	-	2899522 SMJ	
26	15600-ZG4-003	CAP ASSY., OIL FILLER	1	-	-	-	SWX2,SWX4	
28	32302-734-K50	STAY, CORD CLIP (B)	1	-	-	-	VEK	

2

E-7

CRANKSHAFT

F 4

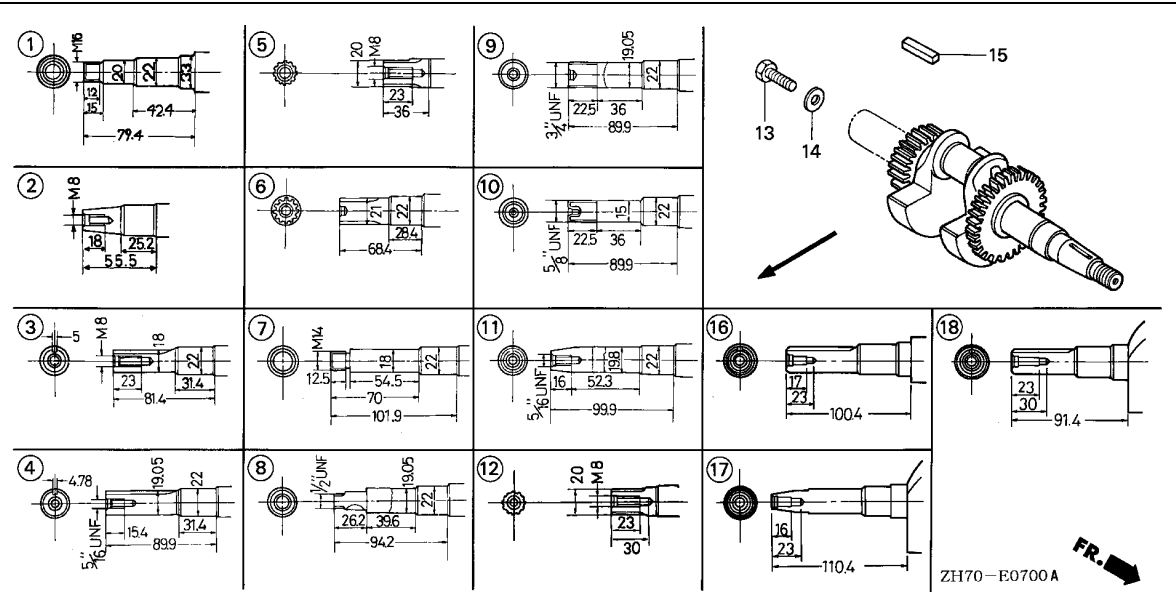

Ref. No.	L.O.N.	(Relative ref. Number) Description	F.R.T.
1	(2,3,4,5,6,7,8,9,10,11,12,16,17,18)	1101F0 CRANKSHAFT	1.1

ZH70-E0700A

Ref. No.	Part No.	Description	Reqd. QTY				Serial No.	Parts catalogue code
			(1)	(2)	(3)	(4)		
1	13310-YB3-010	CRANKSHAFT COMP.	1	-	1	-	WIH1,WJP,WJP1,WME2,WME4	
2	13310-ZB0-000	CRANKSHAFT COMP.	1	-	-	-	EN,ET,ETX,VED,VED1,VED6,VEE1,VEK,VET,VMT	
3	13310-ZE0-000	CRANKSHAFT COMP.	1	1	-	-	RD,RD4,RH,RHC,RHQ4,RX,RX4,R1,SAD2,SAJ,SAJ4,SCJ,SD,SDB1,SDB3,SD16,SD4,SE,SG24,SH,SHQ4,SJ,SJC,SJC1,SJC5,SJD2,SKJ,SKR,SMA7,SMJ,SMW2,SM11,SM12,SM14,SN,SSK1,SSK2,SSK3,SSX2,SSX4,STP,STS,SWX2,SWX4,SW2,SW,SWX4,SX4,S1	
4	13310-ZE0-601	CRANKSHAFT COMP.	1	1	1	-	QA,QA2,QA26,QBU2,QB26,QD,QE,QEH,QH,QHQ4,QH2,QH26,QIH1,QJG2,QJW1,QLL,QM,QMA4,QMA8,QME4,QMH,QMX2,QPU,QSJ,QT,QT2,QWA4,QX,QXC,QXC9,QXG,QXG2,QXQ,QXS,QXS2,QXU,QX2,QX26,QX4,Q1	
5	13310-ZE0-610	CRANKSHAFT COMP.	1	1	-	-	DS,KRT,KRT4,KRT6,LAJ4,LD,LDB1,LDB3,LD4,LE,LEH4,LH,LHQ4,LJ,LJC,LJD2,LJS,LJT,LSJ,LSJ4,LT,LTJ,LTK1,LTR,LTS,LW2,LX,LXU,LX2,LX26,LX4,L1	
6	13310-ZE0-621 13310-ZE0-622	CRANKSHAFT COMP.	1 1	1 1	- -	- -	2774250 HH,HHQ4,HTF2,HX,HXQ,HX2,HX26,HX4,H1 2774251 HH,HHQ4,HTF2,HX,HXQ,HX2,HX26,HX4,H1	
7	13310-ZE0-631	CRANKSHAFT COMP.	1	1	-	-	HT2,HXU	
8	13310-ZE0-641	CRANKSHAFT COMP.	1	1	1	-	WDA6,WDJ,WD12,WJ,WJ1,WKD6,WKT2,WKT4,WKT6,WMA3,WM1,W1	
9	13310-ZE0-650	CRANKSHAFT COMP.	1	-	-	-	UH,UIH,UX,UXU,U1	
10	13310-ZE0-660	CRANKSHAFT COMP.	1	-	-	-	PH,PM,PM2,PX,PX2	
			-	-	-	1	TH,TX,TX2,TX26,TX4	
11	13310-ZE0-670	CRANKSHAFT COMP.	1	1	-	-	VA,VAX4,VEX,VH,VMS4,VPR4,VS,VSX,VSX1,VS1,VX,VXU,VX4,V1	
12	13310-ZK7-V00	CRANKSHAFT COMP.	1	-	-	-	AR,DKR,KR,KRA4,KRF4,KRS4	
13	90003-ZE1-000	BOLT, HEX., 5/16"	1	(1)	-	-	QSJ,Q1,V1	
			(1)	-	-	-	QT	
	92000-08025-0A	BOLT, HEX., 8X25	1	(1)	-	-	LJ,L1,R1,SJ,SMJ,SN,STS,S1	

2

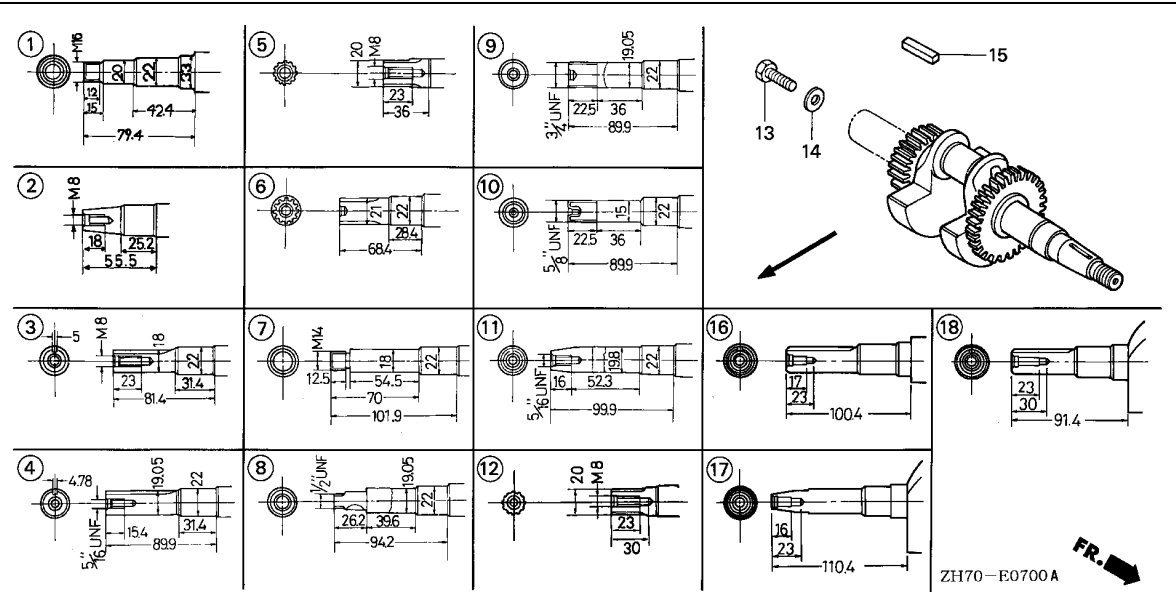

Ref. No.	Part No.	Description	Reqd. QTY				Serial No.	Parts catalogue code
			(1)	(2)	(3)	(4)		
13)	92101-08025-0A	BOLT, HEX., 8X25	1	-	1	-	LAJ4, LJC, LJS, LJT, LSJ, LSJ4, LTA, LTJ, LTK1, LTR, LTS, RHC, SAJ, SAJ4, SCJ, SJC, SJC1, SJC5, SKJ, SKR, SMW2, SM11, SM12, SM14, SSK1, SSK2, SSK3, SSK4, STP, WIH1	
14	90473-842-000	WASHER, 8MM	1	(1)	1	-	LAJ4, LJ, LJC, LJS, LJT, LSJ, LSJ4, LTJ, LTK1, LTR, LTS, L1, QIH1, QSJ, QT, Q1, RHC, R1, SAJ, SAJ4, SCJ, SJ, SJC, SJC1, SJC5, SKJ, SKR, SMJ, SMW2, SM11, SM12, SM14, SN, SSK1, SSK2, SSK3, SSK4, STP, STS, S1, V1, WIH1	
15	90741-883-810	KEY, 5X5X33(YELLOW)	1	(1)	1	-	KRT, KRT6, LSJ, LTR, LTS, RD, SAD2, SAJ, SAJ4, SCJ, SD, SDB1, SDB3, SD16, SD4, SE, SH, SHQ4, SJ, SJC, SJC1, SJC5, SJD2, SKJ, SKR, SMA7, SMJ, SM11, SM12, SM14, SN, SSK1, SSK3, SSK4, STP, STS, SWX2, SWX4, SX, SXS4, SX4, SX7, S1, WIH1	
	90745-ZE1-600	KEY, 4.78X4.78X38	1	(1)	1	-	QA, QAA2, QA2, QA26, QBU2, QD, QE, QIH1, QJG2, QJW1, QLL, QMA4, QMA8, QMH, QPU, QSJ, QT, QTC2, QWA4, QX, QXC, QXC9, QXG, QXG2, QXQ, QXS, QXS2, QXU, QX2, QX26, QX4, QX7, Q1	
			1	-	-	2304978	QEH	
16	13310-ZK7-600	CRANKSHAFT COMP.	1	-	-	-	QX7	
17	13310-ZK7-670	CRANKSHAFT COMP.	1	-	-	-	VEX7, VX7	
18	13310-ZK7-880	CRANKSHAFT COMP.	1	-	-	-	SX7	



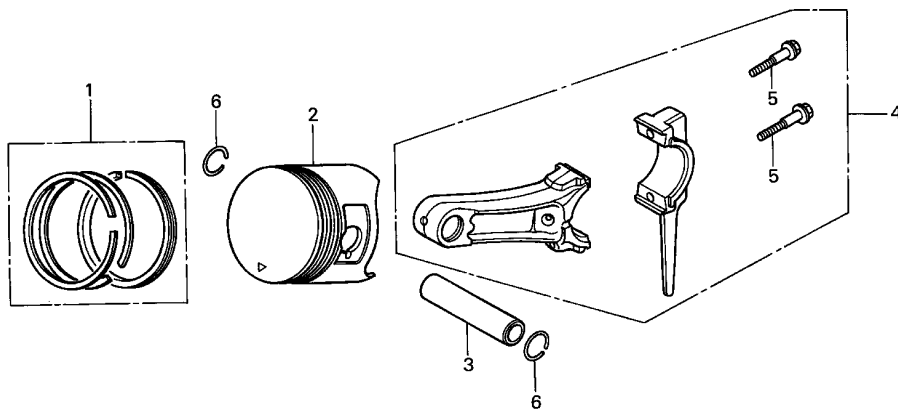

ZH70-E0800



Ref. No.	L.O.N.	(Relative ref. Number) Description	F.R.T.
2	1111R1	(1,3,4) PISTON AND/OR RING SET AND/OR BEARING AND/OR ROD ..... INCLUDES: Inspection/ Measurement/Cleaning	1.2

Ref. No.	Part No.	Description	Reqd. QTY				Serial No.	Parts catalogue code
			(1)	(2)	(3)	(4)		
1	13010-ZE6-003	RING SET, PISTON (STD.) .....	1	1	-	-	3284616	DS,HX,H1,LD,LJ,LX,PH,PX,QD,QSJ,QX,Q1,RD,RX,R1,SD,SJ,SMJ,STS,SX TH,UH,UX,U1,VET,VH,VX,V1,WJ,W1
	13010-ZE6-004	.....	1	1	-	-	3284616	DS,HX,H1,LD,LJ,LX,PH,PX,QD,QSJ,QX,Q1,RD,RX,R1,SD,SJ,SMJ,STS,SX TH,UH,UX,U1,VET,VH,VX,V1,WJ,W1
	13011-ZE6-003	RING SET, PISTON (0.25) .....	(1)	(1)	-	-	3284616	DS,HX,H1,LD,LJ,LX,PH,PX,QD,QSJ,QX,Q1,RD,RX,R1,SD,SJ,SMJ,STS,SX TH,UH,UX,U1,VET,VH,VX,V1,WJ,W1
	13011-ZE6-004	.....	(1)	(1)	-	-	3284616	DS,HX,H1,LD,LJ,LX,PH,PX,QD,QSJ,QX,Q1,RD,RX,R1,SD,SJ,SMJ,STS,SX TH,UH,UX,U1,VET,VH,VX,V1,WJ,W1
	13012-ZE6-003	RING SET, PISTON (0.50) .....	(1)	(1)	-	-	3284616	DS,HX,H1,LD,LJ,LX,PH,PX,QD,QSJ,QX,Q1,RD,RX,R1,SD,SJ,SMJ,STS,SX TH,UH,UX,U1,VET,VH,VX,V1,WJ,W1
	13012-ZE6-004	.....	(1)	(1)	-	-	3284616	DS,HX,H1,LD,LJ,LX,PH,PX,QD,QSJ,QX,Q1,RD,RX,R1,SD,SJ,SMJ,STS,SX TH,UH,UX,U1,VET,VH,VX,V1,WJ,W1
	13013-ZE6-003	RING SET, PISTON (0.75) .....	(1)	(1)	-	-	3284616	DS,HX,H1,LD,LJ,LX,PH,PX,QD,QSJ,QX,Q1,RD,RX,R1,SD,SJ,SMJ,STS,SX TH,UH,UX,U1,VET,VH,VX,V1,WJ,W1
	13013-ZE6-004	.....	(1)	(1)	-	-	3284616	DS,HX,H1,LD,LJ,LX,PH,PX,QD,QSJ,QX,Q1,RD,RX,R1,SD,SJ,SMJ,STS,SX TH,UH,UX,U1,VET,VH,VX,V1,WJ,W1
	13010-ZE6-013	RING SET, PISTON (STD.) (NIPPON)	1	1	-	-	-----	EN,ET,ETX,HH,HXQ,LDB1,LD4,LE,LW2,PM2,QAA2,QBU2,QXG,QXQ,QXS,RH SAD2,SSK2,SW2,U1,VA,VH,VS1,V1
			1	1	-	-	3284616	HHQ4,HTF2,HX,HX2,HX26,HX4,H1,LD,LDB3,LEH4,LH,LHQ4,LJD2,LJT,LSJ LSJ4,LTA,LTJ,LTR,LX,LX2,LX26,LX4,L1,PH,PM,PX,PX2,QA,QA2,QA26 QB26,QD,QE,QEH,QH,QHQ4,QH2,QH26,QJG2,QJW1,QLL,QM,QMA4,QMA8 QME4,QMH,QMX2,QPU,QT,QTC2,QX,QXC,QXC9,QXG2,QXS2,QX2,QX26,QX4 Q1,RD,RD4,RHC,RHQ4,RX,RX4,R1,SAJ,SCJ,SD,SDB1,SDB3,SD16,SD4,SE SG24,SH,SHQ4,SJC,SJC1,SJC5,SKJ,SMA7,SMW2,SN,SSK1,SSK3,SSX4,STP SX,SX4,S1,TH,TX,TX2,TX26,TX4,UH,UX,VAX4,VED,VED1,VEE1,VEX,VMS4 VPR4,VS,VSX,VSX1,VX,VX4,WDJ,WD12,WJP,WJP1,WJ1,WKT2,WMA3,WME2 WM1,W1

Ref. No.	Part No.	Description	Reqd. QTY				Serial No.	Parts catalogue code
			(1)	GX120K1 (2)	(3)	(4)		
(1)	13010-ZE6-014	RING SET, PISTON (STD.) (TEIKOKU)	1	1	-	-	-----	EN,ET,ETX,HH,HXQ,LDB1,LD4,LE,LW2,PM2,QAA2,QBU2,QXG,QXQ,QXS,RH SAD2,SSK2,SW2,U1,VA,VH,VS1,V1
			1	1	-	-	-----	3284616 HHQ4,HTF2,HX,HX2,HX26,HX4,H1,LD,LDB3,LEH4,LH,LHQ4,LJD2,LJT,LSJ LSJ4,LTA,LTJ,LTR,LX,LX2,LX26,LX4,L1,PH,PM,PX,FX2,QA,QA2,QA26 QB26,QD,QE,QEH,QH,QHQ4,QH2,QH26,QJG2,QJW1,QLL,QM,QMA4,QMA8 QME4,QMH,QMX2,QPU,QT,QTC2,QX,QXC,QXC9,QXG2,QXS2,QX2,QX26,QX4 Q1,RD,RD4,RHC,RHQ4,RX,RX4,R1,SAJ,SCJ,SD,SDB1,SDB3,SD16,SD4,SE SG24,SH,SHQ4,SJC,SJC1,SJC5,SKJ,SMA7,SMW2,SN,SSK1,SSK3,SSX4,STP SX,SX4,S1,TH,TX,TX2,TX26,TX4,UH,UX,VAX4,VED,VED1,VEE1,VEX,VMS4 VPR4,VS,VSX,VSX1,VX,VX4,WDJ,WD12,WJP,WJP1,WJ1,WKT2,WMA3,WME2 WM1,W1
	13011-ZE6-013	RING SET, PISTON (0.25) (NIPPON)	(1)	(1)	(1)	-	-----	EN,ET,ETX,HH,HXQ,LDB1,LD4,LE,LW2,PM2,QAA2,QBU2,QXG,QXQ,QXS,RH SAD2,SSK2,SW2,UIH,U1,VA,VH,VS1,V1
			(1)	(1)	-	-	-----	3284616 HHQ4,HTF2,HX,HX2,HX26,HX4,H1,LD,LDB3,LEH4,LH,LHQ4,LJD2,LJT,LSJ LSJ4,LTA,LTJ,LTR,LX,LX2,LX26,LX4,L1,PH,PM,PX,FX2,QA,QA2,QA26 QB26,QD,QE,QEH,QH,QHQ4,QH2,QH26,QJG2,QJW1,QLL,QM,QMA4,QMA8 QME4,QMH,QMX2,QPU,QT,QTC2,QX,QXC,QXC9,QXG2,QXS2,QX2,QX26,QX4 Q1,RD,RD4,RHC,RHQ4,RX,RX4,R1,SAJ,SCJ,SD,SDB1,SDB3,SD16,SD4,SE SG24,SH,SHQ4,SJC,SJC1,SJC5,SKJ,SMA7,SMW2,SN,SSK1,SSK3,SSX4,STP SX,SX4,S1,TH,TX,TX2,TX26,TX4,UH,UX,VAX4,VED,VED1,VEE1,VEX,VMS4 VPR4,VS,VSX,VSX1,VX,VX4,WDJ,WD12,WJP,WJP1,WJ1,WKT2,WMA3,WME2 WM1,W1
	13011-ZE6-014	RING SET, PISTON (0.25) (TEIKOKU)	(1)	(1)	(1)	-	-----	EN,ET,ETX,HH,HXQ,LDB1,LD4,LE,LW2,PM2,QAA2,QBU2,QXG,QXQ,QXS,RH SAD2,SSK2,SW2,UIH,U1,VA,VH,VS1,V1
			(1)	(1)	-	-	-----	3284616 HHQ4,HTF2,HX,HX2,HX26,HX4,H1,LD,LDB3,LEH4,LH,LHQ4,LJD2,LJT,LSJ LSJ4,LTA,LTJ,LTR,LX,LX2,LX26,LX4,L1,PH,PM,PX,FX2,QA,QA2,QA26 QB26,QD,QE,QEH,QH,QHQ4,QH2,QH26,QJG2,QJW1,QLL,QM,QMA4,QMA8 QME4,QMH,QMX2,QPU,QT,QTC2,QX,QXC,QXC9,QXG2,QXS2,QX2,QX26,QX4 Q1,RD,RD4,RHC,RHQ4,RX,RX4,R1,SAJ,SCJ,SD,SDB1,SDB3,SD16,SD4,SE SG24,SH,SHQ4,SJC,SJC1,SJC5,SKJ,SMA7,SMW2,SN,SSK1,SSK3,SSX4,STP SX,SX4,S1,TH,TX,TX2,TX26,TX4,UH,UX,VAX4,VED,VED1,VEE1,VEX,VMS4 VPR4,VS,VSX,VSX1,VX,VX4,WDJ,WD12,WJP,WJP1,WJ1,WKT2,WMA3,WME2 WM1,W1
	13012-ZE6-013	RING SET, PISTON (0.50) (NIPPON)	(1)	(1)	(1)	-	-----	EN,ET,ETX,HH,HXQ,LDB1,LD4,LE,LW2,PM2,QAA2,QBU2,QXG,QXQ,QXS,RH SAD2,SSK2,SW2,UIH,U1,VA,VH,VS1,V1
			(1)	(1)	-	-	-----	3284616 HHQ4,HTF2,HX,HX2,HX26,HX4,H1,LD,LDB3,LEH4,LH,LHQ4,LJD2,LJT,LSJ LSJ4,LTA,LTJ,LTR,LX,LX2,LX26,LX4,L1,PH,PM,PX,FX2,QA,QA2,QA26 QB26,QD,QE,QEH,QH,QHQ4,QH2,QH26,QJG2,QJW1,QLL,QM,QMA4,QMA8 QME4,QMH,QMX2,QPU,QT,QTC2,QX,QXC,QXC9,QXG2,QXS2,QX2,QX26,QX4 Q1,RD,RD4,RHC,RHQ4,RX,RX4,R1,SAJ,SCJ,SD,SDB1,SDB3,SD16,SD4,SE SG24,SH,SHQ4,SJC,SJC1,SJC5,SKJ,SMA7,SMW2,SN,SSK1,SSK3,SSX4,STP SX,SX4,S1,TH,TX,TX2,TX26,TX4,UH,UX,VAX4,VED,VED1,VEE1,VEX,VMS4 VPR4,VS,VSX,VSX1,VX,VX4,WDJ,WD12,WJP,WJP1,WJ1,WKT2,WMA3,WME2 WM1,W1



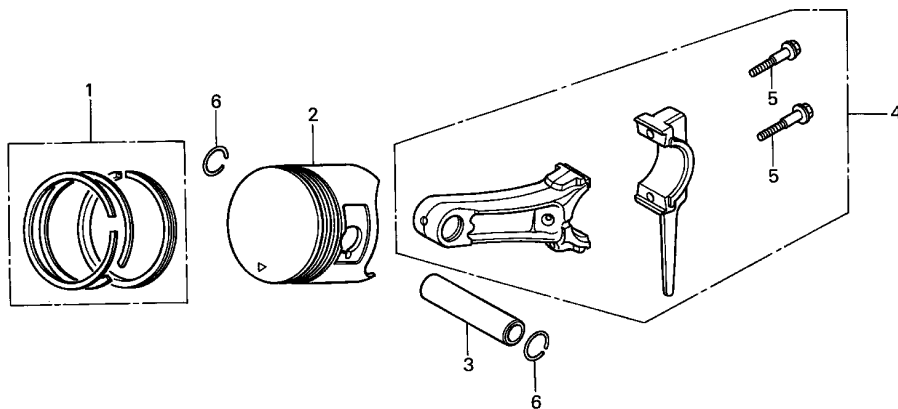

ZH70-E0800



2

Ref. No.	Part No.	Description	Reqd. QTY				Serial No.	Parts catalogue code
			(1)	(2)	(3)	(4)		
(1)	13012-ZE6-014	RING SET, PISTON (0.50) (TEIKOKU)	(1)	(1)	(1)	-	-	EN,ET,ETX,HH,HXQ,LDB1,LD4,LE,LW2,PM2,QAA2,QBU2,QXG,QXQ,QXS,RH SAD2,SSK2,SW2,UIH,U1,VA,VH,VS1,V1
			(1)	(1)	-	-	3284616	HHQ4,HTF2,HX,HX2,HX26,HX4,H1,LD,LDB3,LEH4,LH,LHQ4,LJD2,LJT,LSJ LSJ4,LTA,LTJ,LTR,LX,LX2,LX26,LX4,L1,PH,PM,PX,PX2,QA,QA2,QA26 QB26,QD,QE,QEH,QH,QHQ4,QH2,QH26,QJG2,QJW1,QLL,QM,QMA4,QMA8 QME4,QMH,QMX2,QPU,QT,QTC2,QX,QXC,QXC9,QXG2,QXS2,QX2,QX26,QX4 Q1,RD,RD4,RHC,RHQ4,RX,RX4,R1,SAJ,SCJ,SD,SDB1,SDB3,SD16,SD4,SE SG24,SH,SHQ4,SJC,SJC1,SJC5,SKJ,SMA7,SMW2,SN,SSK1,SSK3,SSX4,STP SX,SX4,S1,TH,TX,TX2,TX26,TX4,UH,UX,VAX4,VED,VED1,VEE1,VEX,VMS4 VPR4,VS,VSX,VSX1,VX,VX4,WDJ,WD12,WJP,WJP1,WJ1,WKT2,WMA3,WME2 WM1,W1
	13013-ZE6-013	RING SET, PISTON (0.75) (NIPPON)	-	-	-	(1)	-	HXQ,QAA2,QXG,QXQ,QXS,SSK2
			(1)	-	-	-	3284616	HTF2,HX,HX2,LJD2,LJT,LSJ,LTA,LTJ,LTR,LX2,PX2,QA,QA2,QH2,QJG2 QJW1,QMX2,QTC2,QX,QXC,QXC9,QXG2,QXS2,QX2,SAJ,SCJ,SG24,SJC,SJC1 SJC5,SKJ,SMW2,SSK1,SSK3,STP,TX,TX2,VEE1,WDJ,WD12,WJP,WJP1,WJ1 WKT2,WME2

Ref. No.	Part No.	Description	Reqd. QTY				Serial No.	Parts catalogue code	
			(1)	GX120K1 (2)	(3)	(4)			
(1)	13013-ZE6-014	RING SET, PISTON (0.75) (TEIKOKU)	(1)	(1)	(1)	-	-----	EN,ET,ETX,HH,HXQ,LDB1,LD4,LE,LW2,PM2,QAA2,QBU2,QXG,QXQ,QXS,RH SAD2,SSK2,SW2,UIH,U1,VA,VH,VS1,V1	
			(1)	(1)	-	-	-----	3284616 HHQ4,HTF2,HX,HX2,HX26,HX4,H1,LD,LDB3,LEH4,LH,LHQ4,LJD2,LJT,LSJ LSJ4,LTA,LTJ,LTR,LX,LX2,LX26,LX4,L1,PH,PM,PX,PX2,QA,QA2,QA26 QB26,QD,QE,QEH,QH,QHQ4,QH2,QH26,QJG2,QJW1,QLL,QM,QMA4,QMA8 QME4,QMH,QMX2,QPU,QT,QTC2,QX,QXC,QXC9,QXG2,QXS2,QX2,QX26,QX4 Q1,RD,RD4,RHC,RHQ4,RX,RX4,R1,SAJ,SCJ,SD,SDB1,SDB3,SD16,SD4,SE SG24,SH,SHQ4,SJ,SJC1,SJC5,SKJ,SMA7,SMW2,SN,SSK1,SSK3,SSX4,STP SX,SX4,S1,TH,TX,TX2,TX26,TX4,UH,UX,VAX4,VED,VED1,VEE1,VET,VEX,VMS4 VPR4,VS,VSX,VSX1,VX,VX4,WDJ,WD12,WJP,WJP1,WJ1,WKT2,WMA3,WME2 WM1,W1	
	13010-ZK7-V01	RING SET, PISTON (STD.) (TEIKOKU)	-	-	-	(1)			
			1	1	-	-	3284617	-----	LDB3,LEH4,LJT,LTA,L1,QA26,QE,QEH,QH2,QJW1,QMH,QPU,QSJ,QXC,SDB1 SDB3,SJC,SN,SSK1,S1,U1,VAX4,VH,VS,V1,WDJ,WJ1,W1
			1	1	-	-	3284617	3993725	DS,HHQ4,HTF2,HX,HX2,HX26,HX4,H1,LD,LH,LHQ4,LJ,LJD2,LSJ,LSJ4 LTJ,LTR,LX,LX2,LX26,LX4,PH,PM,PX,PX2,QA,QA2,QB26,QD,QH,QHQ4 QH26,QJG2,QLL,QM,QMA4,QMA8,QME4,QMX2,QT,QTC2,QX,QXC9,QXG2,QXS2 QX2,QX26,QX4,Q1,RD,RD4,RHC,RHQ4,RX,RX4,R1,SAJ,SCJ,SD,SD16,SD4 SE,SG24,SH,SHQ4,SJ,SJC1,SJC5,SKJ,SMA7,SMJ,SMW2,SSK3,SSX4,STP STS,SX,SX4,TH,TX,TX2,TX26,TX4,UH,UX,VED,VED1,VEE1,VET,VEX,VMS4 VPR4,VSX,VSX1,VX,VX4,WD12,WJ,WJP,WJP1,WKT2,WMA3,WME2,WM1
			1	-	-	-	3993725		AR,DKR,HXU,KR,KRA4,KRT,KRT4,KRT6,LAJ4,LJC,LJS,LTK1,LXU,QWA4 QXU,SAJ4,SKR,SM11,SSX2,SWX2,SWX4,SXS4,UXU,VED6,VMT,VXU,WDA6 WKD6,WKT4,WME4
	13010-ZK7-V02	RING SET, PISTON (STD.) (NIPPON)	-	-	1	1			
			1	1	-	-	3284617	-----	LDB3,LEH4,LJT,LTA,L1,QA26,QE,QEH,QH2,QJW1,QMH,QPU,QSJ,QXC,SDB1 SDB3,SJC,SN,SSK1,S1,U1,VAX4,VH,VS,V1,WDJ,WJ1,W1
			1	1	-	-	3284617	3993725	DS,HHQ4,HTF2,HX,HX2,HX26,HX4,H1,LD,LH,LHQ4,LJ,LJD2,LSJ,LSJ4 LTJ,LTR,LX,LX2,LX26,LX4,PH,PM,PX,PX2,QA,QA2,QB26,QD,QH,QHQ4 QH26,QJG2,QLL,QM,QMA4,QMA8,QME4,QMX2,QT,QTC2,QX,QXC9,QXG2,QXS2 QX2,QX26,QX4,Q1,RD,RD4,RHC,RHQ4,RX,RX4,R1,SAJ,SCJ,SD,SD16,SD4 SE,SG24,SH,SHQ4,SJ,SJC1,SJC5,SKJ,SMA7,SMJ,SMW2,SSK3,SSX4,STP STS,SX,SX4,TH,TX,TX2,TX26,TX4,UH,UX,VED,VED1,VEE1,VET,VEX,VMS4 VPR4,VSX,VSX1,VX,VX4,WD12,WJ,WJP,WJP1,WKT2,WMA3,WME2,WM1
			1	-	-	-	3993725		HXU,LAJ4,LJC,LJS,LTK1,LXU,QWA4,QXU,SAJ4,SKR,SM11,SSX2,SWX2 SWX4,SXS4,UXU,VED6,VMT,VXU,WDA6,WKD6,WKT4,WME4
	13010-ZH7-003	RING SET, PISTON (STD.) (TEIKOKU)	-	-	1	1			
			1	1	-	-	3993726	-----	AR,DKR,DS,HHQ4,HTF2,HX,HXU,HX2,HX26,HX4,H1,KR,KRA4,KRT,KRT4 KRT6,LAJ4,LD,LH,LHQ4,LJ,LJC,LJD2,LJS,LSJ,LSJ4,LTJ,LTK1,LTR,LX LXU,LX2,LX26,LX4,PH,PM,PX,PX2,QA,QA2,QB26,QD,QH,QHQ4,QH26,QJG2 QLL,QM,QMA4,QMA8,QME4,QMX2,QT,QTC2,QWA4,QX,QXC9,QXG2,QXS2,QXU QX2,QX26,QX4,Q1,RD,RD4,RHC,RHQ4,RX,RX4,R1,SAJ,SAJ4,SCJ,SD,SD16 SD4,SE,SG24,SH,SHQ4,SJ,SJC1,SJC5,SKJ,SKR,SMA7,SMJ,SMW2,SM11 SSK3,SSX2,SSX4,STP,STS,SWX2,SWX4,SX,SXS4,SX4,TH,TX,TX2,TX26 TX4,UH,UX,UXU,VED,VED1,VED6,VEE1,VET,VEX,VMS4,VMT,VPR4,VSX VSX1,VX,VXU,VX4,WDA6,WD12,WJ,WJP,WJP1,WKD6,WKT2,WKT4,WMA3,WME2 WME4,WM1
			1	-	-	-	-----	-----	HT2,KRF4,KRS4,LTS,QX7,SJD2,SM12,SM14,SX7,VEK,VEX7,VX7,WKT6

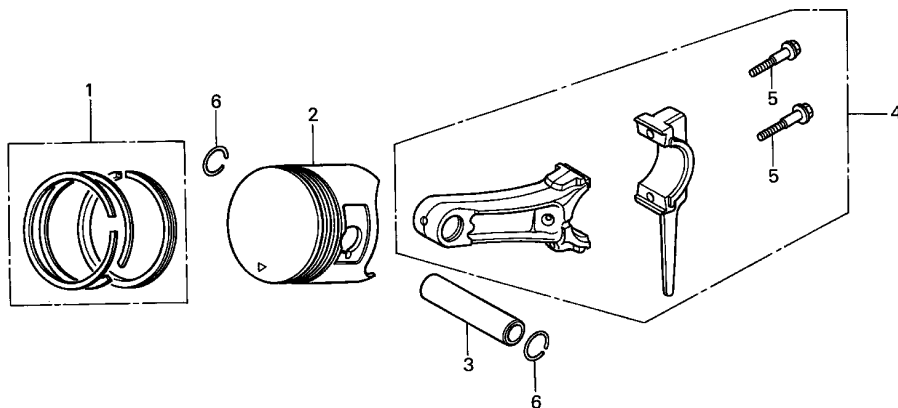

ZH70-E0800



Ref. No.	Part No.	Description	Reqd. QTY				Serial No.	Parts catalogue code
			(1)	(2)	(3)	(4)		
(1)	13010-ZH7-004	RING SET, PISTON (STD.) (NIPPON)	1	1	-	-	3993726	AR,DKR,DS,HHQ4,HTF2,HX,HXU,HX2,HX26,HX4,H1,KR,KRA4,KRT,KRT4,KRT6,LAJ4,LD,LH,LHQ4,LJ,LJC,LJD2,LJS,LSJ,LSJ4,LTJ,LTk1,LTR,LX,LXU,LX2,LX26,LX4,PH,PM,PX,PX2,QA,QA2,QB26,QD,QH,QHQ4,QH26,QJG2,QLL,QM,QMA4,QMA8,QME4,QMX2,QT,QTC2,QWA4,QX,QXC9,QXG2,QXS2,QXU,QX2,QX26,QX4,Q1,RD,RD4,RHC,RHQ4,RX,RX4,R1,SAJ,SAJ4,SCJ,SD,SD16,SD4,SE,SG24,SH,SHQ4,SJ,SJC1,SJC5,SKJ,SKR,SMA7,SMJ,SMW2,SM11,SSK3,SSX2,SSX4,STP,STS,SWX2,SWX4,SX,SXS4, SX4,TH, TX, TX2, TX26, TX4, UH, UX, UXU, VED, VED1, VED6, VEE1, VET, VEX, VMS4, VMT, VPR4, VSX, VSX1, VX, VXU, VX4, WDA6, WD12, WJ, WJP, WJP1, WKD6, WKT2, WKT4, WMA3, WME2, WME4, WM1
	13011-ZK7-V01	RING SET, PISTON (0.25) (TEIKOKU)	1	-	-	-	HT2,KRF4,KRS4,LTS,QX7,SJD2,SM12,SM14,SX7,VEK,VEX7,VX7,WKT6	
			(1)	(1)	-	-	3284617	LDB3,LEH4,LJT,LTA,L1,QA26,QE,QEH,QH2,QJW1,QMH,QPU,QSJ,QXC,SDB1,SDB3,SJC,SN,SSK1,S1,U1,VAX4,VH,VS,V1,WDJ,WJ1,W1
			(1)	(1)	-	-	3284617	3993725 DS,HHQ4,HTF2,HX,HX2,HX26,HX4,H1,LD,LH,LHQ4,LJ,LJD2,LSJ,LSJ4,LTJ,LTR,LX,LX2,LX26,LX4,PH,PM,PX,PX2,QA,QA2,QB26,QD,QH,QHQ4,QH26,QJG2,QLL,QM,QMA4,QMA8,QME4,QMX2,QT,QTC2,QX,QXC9,QXG2,QXS2,QX2,QX26,QX4,Q1,RD,RD4,RHC,RHQ4,RX,RX4,R1,SAJ,SCJ,SD,SD16,SD4,SE,SG24,SH,SHQ4,SJ,SJC1,SJC5,SKJ,SMA7,SMJ,SMW2,SSK3,SSX4,STP,STS,SX, SX4, TH, TX, TX2, TX26, TX4, UH, UX, VED, VED1, VEE1, VET, VEX, VMS4, VPR4, VSX, VSX1, VX, VX4, WD12, WJ, WJP, WJP1, WKT2, WMA3, WME2, WM1
			(1)	-	-	-	3993725	AR,DKR,HXU,KR,KRA4,KRT,KRT4,KRT6,LAJ4,LJC,LJS,LTk1,LXU,QWA4,QXU,SAJ4,SKR,SM11,SSX2,SWX2,SWX4,SXS4,UXU,VED6,VMT,VXU,WDA6,WKD6,WKT4,WME4
			-	-	(1)	-	-----	QIH1,UIH
			-	-	-	(1)	-----	

Ref. No.	Part No.	Description	Reqd. QTY				Serial No.	Parts catalogue code
			(1)	(2)	(3)	(4)		
(1)	13011-ZK7-V02	RING SET, PISTON (0.25) (NIPPON)	(1)	(1)	-	-	3284617	LDB3, LEH4, LJT, LTA, L1, QA26, QE, QEH, QH2, QJW1, QMH, QPU, QSJ, QXC, SDB1
			(1)	(1)	-	-	3284617	SDB3, SJC, SN, SSK1, S1, U1, VAX4, VH, VS, V1, WDJ, WJ1, W1
			(1)	(1)	-	-	3993725	DS, HHQ4, HTF2, HX, HX2, HX26, HX4, H1, LD, LH, LHQ4, LJ, LJD2, LSJ, LSJ4
			(1)	(1)	-	-	3993725	LTJ, LTR, LX, LX2, LX26, LX4, PH, PM, PX, PX2, QA, QA2, QB26, QD, QH, QHQ4
			(1)	(1)	-	-	3993725	QH26, QJG2, QLL, QM, QMA4, QMA8, QME4, QMX2, QT, QTC2, QX, QXC9, QXG2, QXS2
			(1)	(1)	-	-	3993725	QX2, QX26, QX4, Q1, RD, RD4, RHC, RHQ4, RX, RX4, R1, SAJ, SCJ, SD, SD16, SD4
			(1)	(1)	-	-	3993725	SE, SG24, SH, SHQ4, SJ, SJC1, SJC5, SKJ, SMA7, SMJ, SMW2, SSK3, SSX4, STP
			(1)	(1)	-	-	3993725	STS, SX, SX4, TH, TX, TX2, TX26, TX4, UH, UX, VED, VED1, VEE1, VET, VEX, VMS4
			(1)	(1)	-	-	3993725	VPR4, VSX, VSX1, VX, VX4, WD12, WJ, WJP, WJP1, WKT2, WMA3, WME2, WM1
			(1)	(1)	-	-	3993725	HXU, LAJ4, LJC, LJS, LTK1, LXU, QWA4, QXU, SAJ4, SKR, SM11, SSX2, SWX2
			(1)	(1)	-	-	3993725	SWX4, SXS4, UXU, VED6, VMT, VXU, WDA6, WKD6, WKT4, WME4
			(1)	(1)	-	-	3993725	QIH1, UIH
			(1)	(1)	-	-	3993726	AR, DKR, DS, HHQ4, HTF2, HX, HXU, HX2, HX26, HX4, H1, KR, KRA4, KRT, KRT4
			(1)	(1)	-	-	3993726	KRT6, LAJ4, LD, LH, LHQ4, LJ, LJC, LJD2, LJS, LSJ, LSJ4, LTJ, LTK1, LTR, LX
			(1)	(1)	-	-	3993726	LXU, LX2, LX26, LX4, PH, PM, PX, PX2, QA, QA2, QB26, QD, QH, QHQ4, QH26, QJG2
			(1)	(1)	-	-	3993726	QLL, QM, QMA4, QMA8, QME4, QMX2, QT, QTC2, QWA4, QX, QXC9, QXG2, QXS2, QXU
			(1)	(1)	-	-	3993726	QX2, QX26, QX4, Q1, RD, RD4, RHC, RHQ4, RX, RX4, R1, SAJ, SAJ4, SCJ, SD, SD16
			(1)	(1)	-	-	3993726	SD4, SE, SG24, SH, SHQ4, SJ, SJC1, SJC5, SKJ, SKR, SMA7, SMJ, SMW2, SM11
			(1)	(1)	-	-	3993726	SSK3, SSX2, SSX4, STP, STS, SWX2, SWX4, SX, SXS4, SX4, TH, TX, TX2, TX26
			(1)	(1)	-	-	3993726	TX4, UH, UX, UXU, VED, VED1, VED6, VEE1, VET, VEX, VMS4, VMT, VPR4, VSX
			(1)	(1)	-	-	3993726	VSX1, VX, VXU, VX4, WDA6, WD12, WJ, WJP, WJP1, WKD6, WKT2, WKT4, WMA3, WME2
			(1)	(1)	-	-	3993726	WME4, WM1
			(1)	(1)	-	-	3993726	HT2, KRF4, KRS4, LTS, QX7, SJD2, SM12, SM14, SX7, VEK, VEX7, VX7, WKT6
			(1)	(1)	-	-	3993726	AR, DKR, DS, HHQ4, HTF2, HX, HXU, HX2, HX26, HX4, H1, KR, KRA4, KRT, KRT4
			(1)	(1)	-	-	3993726	KRT6, LAJ4, LD, LH, LHQ4, LJ, LJC, LJD2, LJS, LSJ, LSJ4, LTJ, LTK1, LTR, LX
			(1)	(1)	-	-	3993726	LXU, LX2, LX26, LX4, PH, PM, PX, PX2, QA, QA2, QB26, QD, QH, QHQ4, QH26, QJG2
			(1)	(1)	-	-	3993726	QLL, QM, QMA4, QMA8, QME4, QMX2, QT, QTC2, QWA4, QX, QXC9, QXG2, QXS2, QXU
			(1)	(1)	-	-	3993726	QX2, QX26, QX4, Q1, RD, RD4, RHC, RHQ4, RX, RX4, R1, SAJ, SAJ4, SCJ, SD, SD16
			(1)	(1)	-	-	3993726	SD4, SE, SG24, SH, SHQ4, SJ, SJC1, SJC5, SKJ, SKR, SMA7, SMJ, SMW2, SM11
			(1)	(1)	-	-	3993726	SSK3, SSX2, SSX4, STP, STS, SWX2, SWX4, SX, SXS4, SX4, TH, TX, TX2, TX26
			(1)	(1)	-	-	3993726	TX4, UH, UX, UXU, VED, VED1, VED6, VEE1, VET, VEX, VMS4, VMT, VPR4, VSX
			(1)	(1)	-	-	3993726	VSX1, VX, VXU, VX4, WDA6, WD12, WJ, WJP, WJP1, WKD6, WKT2, WKT4, WMA3, WME2
			(1)	(1)	-	-	3993726	WME4, WM1
			(1)	(1)	-	-	3993726	HT2, KRF4, KRS4, LTS, QX7, SJD2, SM12, SM14, SX7, VEK, VEX7, VX7, WKT6
			(1)	(1)	-	-	3284617	LDB3, LEH4, LJT, LTA, L1, QA26, QE, QEH, QH2, QJW1, QMH, QPU, QSJ, QXC, SDB1
			(1)	(1)	-	-	3284617	SDB3, SJC, SN, SSK1, S1, U1, VAX4, VH, VS, V1, WDJ, WJ1, W1
			(1)	(1)	-	-	3993725	DS, HHQ4, HTF2, HX, HX2, HX26, HX4, H1, LD, LH, LHQ4, LJ, LJD2, LSJ, LSJ4
			(1)	(1)	-	-	3993725	LTJ, LTR, LX, LX2, LX26, LX4, PH, PM, PX, PX2, QA, QA2, QB26, QD, QH, QHQ4
			(1)	(1)	-	-	3993725	QH26, QJG2, QLL, QM, QMA4, QMA8, QME4, QMX2, QT, QTC2, QX, QXC9, QXG2, QXS2
			(1)	(1)	-	-	3993725	QX2, QX26, QX4, Q1, RD, RD4, RHC, RHQ4, RX, RX4, R1, SAJ, SCJ, SD, SD16, SD4
			(1)	(1)	-	-	3993725	SE, SG24, SH, SHQ4, SJ, SJC1, SJC5, SKJ, SMA7, SMJ, SMW2, SSK3, SSX4, STP
			(1)	(1)	-	-	3993725	STS, SX, SX4, TH, TX, TX2, TX26, TX4, UH, UX, VED, VED1, VEE1, VET, VEX, VMS4
			(1)	(1)	-	-	3993725	VPR4, VSX, VSX1, VX, VX4, WD12, WJ, WJP, WJP1, WKT2, WMA3, WME2, WM1
			(1)	(1)	-	-	3993725	AR, DKR, HXU, KR, KRA4, KRT, KRT4, KRT6, LAJ4, LJC, LJS, LTK1, LXU, QWA4
			(1)	(1)	-	-	3993725	QXU, SAJ4, SKR, SM11, SSX2, SWX2, SWX4, SXS4, UXU, VED6, VMT, VXU, WDA6
			(1)	(1)	-	-	3993725	WKD6, WKT4, WME4
			(1)	(1)	-	-	3993725	QIH1, UIH



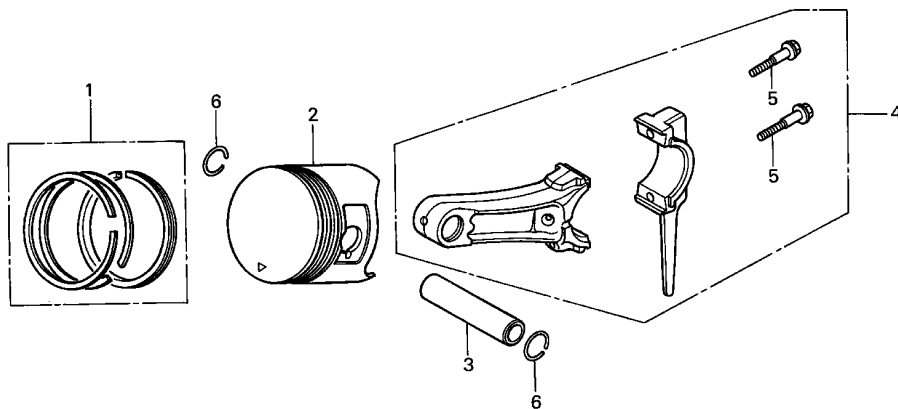

ZH70-E0800



Ref. No.	Part No.	Description	Reqd. QTY				Serial No.	Parts catalogue code
			(1)	(2)	(3)	(4)		
(1)	13012-ZK7-V02	RING SET, PISTON (0.50)						
		(NIPPON)	(1)	(1)	-	-	3284617	----- LDB3, LEH4, LJT, LTA, L1, QA26, QE, QEH, QH2, QJW1, QMH, QPU, QSJ, QXC, SDB1
			(1)	(1)	-	-	3284617	3993725 DS, HHQ4, HTF2, HX, HX2, HX26, HX4, H1, LD, LH, LHQ4, LJ, LJD2, LSJ, LSJ4
								LTJ, LTR, LX, LX2, LX26, LX4, PH, PM, PX, PX2, QA, QA2, QB26, QD, QH, QHQ4
								QH26, QJG2, QLL, QM, QMA4, QMA8, QME4, QMX2, QT, QTC2, QX, QXC9, QXG2, QXS2
								QX2, QX26, QX4, Q1, RD, RD4, RHC, RHQ4, RX, RX4, R1, SAJ, SCJ, SD, SD16, SD4
								SE, SG24, SH, SHQ4, SJ, SJC1, SJC5, SKJ, SMA7, SMJ, SMW2, SSK3, SSX4, STP
								STS, SX, SX4, TH, TX, TX2, TX26, TX4, UH, UX, VED, VED1, VEE1, VET, VEX, VMS4
								VPR4, VSX, VSX1, VX, VX4, WD12, WJ, WJP, WJP1, WKT2, WMA3, WME2, WM1
			(1)	-	-	-	3993725	HXU, LAJ4, LJC, LJS, LTK1, LXU, QWA4, QXU, SAJ4, SKR, SM11, SSSX2, SWX2
			-	-	(1)	-	-----	SWX4, SXS4, UXU, VED6, VMT, VXU, WDA6, WKD6, WKT4, WME4
			-	-	(1)	-	-----	QIH1, UIH
	13012-ZH7-003	RING SET, PISTON (0.50)						
		(TEIKOKU)	(1)	(1)	-	-	3993726	----- AR, DKR, DS, HHQ4, HTF2, HX, HXU, HX2, HX26, HX4, H1, KR, KRA4, KRT, KRT4
								KRT6, LAJ4, LD, LH, LHQ4, LJ, LJC, LJD2, LJS, LSJ, LSJ4, LTJ, LTK1, LTR, LX
								LXU, LX2, LX26, LX4, PH, PM, PX, PX2, QA, QA2, QB26, QD, QH, QHQ4, QH26, QJG2
								QLL, QM, QMA4, QMA8, QME4, QMX2, QT, QTC2, QWA4, QX, QXC9, QXG2, QXS2, QXU
								QX2, QX26, QX4, Q1, RD, RD4, RHC, RHQ4, RX, RX4, R1, SAJ, SAJ4, SCJ, SD, SD16
								SD4, SE, SG24, SH, SHQ4, SJ, SJC1, SJC5, SKJ, SKR, SMA7, SMJ, SMW2, SM11
								SSK3, SSSX2, SSSX4, STP, STS, SWX2, SWX4, SX, SXS4, SX4, TH, TX, TX2, TX26
								TX4, UH, UX, UXU, VED, VED1, VED6, VEE1, VET, VEX, VMS4, VMT, VPR4, VSX
								VSX1, VX, VXU, VX4, WDA6, WD12, WJ, WJP, WJP1, WKD6, WKT2, WKT4, WMA3, WME2
			(1)	-	-	-	-----	WME4, WM1
								HT2, KRF4, KRS4, LTS, QX7, SJD2, SM12, SM14, SX7, VEK, VEX7, VX7, WKT6

Ref. No.	Part No.	Description	Reqd. QTY				Serial No.	Parts catalogue code
			(1)	(2)	(3)	(4)		
(1)	13012-ZH7-004	RING SET, PISTON (0.50) (NIPPON)	(1)	(1)	-	-	3993726	AR,DKR,DS,HHQ4,HTF2,HX,HXU,HX2,HX26,HX4,H1,KR,KRA4,KRT,KRT4,KRT6,LAJ4,LD,LH,LHQ4,LJ,LJC,LJD2,LJS,LSJ,LSJ4,LTJ,LTK1,LTR,LX,LXU,LX2,LX26,LX4,PH,PM,PX,PX2,QA,QA2,QB26,QD,QH,QHQ4,QH26,QJG2,QLL,QM,QMA4,QMA8,QME4,QMX2,QT,QTC2,QWA4,QX,QXC9,QXG2,QXS2,QXU,QX2,QX26,QX4,Q1,RD,RD4,RHC,RHQ4,RX,RX4,R1,SAJ,SAJ4,SCJ,SD,SD16,SD4,SE,SG24,SH,SHQ4,SJ,SJC1,SJC5,SKJ,SKR,SM7,SMJ,SMW2,SM11,SSK3,SSX2,SSX4,STP,STS,SWX2,SWX4,SX,SXS4, SX4,TH,TX,TX2,TX26,TX4,UH,UX,UXU,VED,VED1,VED6,VEE1,VET,VEX,VMS4,VMT,VPR4,VSX,VSX1,VX,VXU,VX4,WDA6,WD12,WJ,WJP,WJP1,WKD6,WKT2,WKT4,WMA3,WME2,WME4,WM1
	13013-ZK7-V01	RING SET, PISTON (0.75) (TEIKOKU)	(1)	-	-	-		HT2,KRF4,KRS4,LTS,QX7,SJD2,SM12,SM14,SX7,VEK,VEX7,VX7,WKT6
			(1)	(1)	-	-	3284617	LDB3,LEH4,LJT,LTA,L1,QA26,QE,QEH,QH2,QJW1,QMH,QPU,QSJ,QXC,SDB1,SDB3,SJC,SN,SSK1,S1,U1,VAX4,VH,VS,V1,WDJ,WJ1,W1
			(1)	(1)	-	-	3284617	3993725 DS,HHQ4,HTF2,HX,HX2,HX26,HX4,H1,LD,LH,LHQ4,LJ,LJD2,LSJ,LSJ4,LTJ,LTR,LX,LX2,LX26,LX4,PH,PM,PX,PX2,QA,QA2,QB26,QD,QH,QHQ4,QH26,QJG2,QLL,QM,QMA4,QMA8,QME4,QMX2,QT,QTC2,QX,QXC9,QXG2,QXS2,QX2,QX26,QX4,Q1,RD,RD4,RHC,RHQ4,RX,RX4,R1,SAJ,SCJ,SD,SD16,SD4,SE,SG24,SH,SHQ4,SJ,SJC1,SJC5,SKJ,SM7,SMJ,SMW2,SSK3,SSX4,STP,STS,SX,SX4,TH,TX,TX2,TX26,TX4,UH,UX,VED,VED1,VEE1,VET,VEX,VMS4,VPR4,VSX,VSX1,VX,VX4,WD12,WJ,WJP,WJP1,WKT2,WMA3,WME2,WM1
			(1)	-	-	-	3993725	AR,DKR,HXU,KR,KRA4,KRT,KRT4,KRT6,LAJ4,LJC,LJS,LTK1,LXU,QWA4,QXU,SAJ4,SKR,SM11,SSX2,SWX2,SWX4,SXS4,UXU,VED6,VMT,VXU,WDA6,WKD6,WKT4,WME4
			-	-	(1)	-		QIH1,UIH
			-	-	-	(1)		
	13013-ZK7-V02	RING SET, PISTON (0.75) (NIPPON)	(1)	(1)	-	-	3284617	LDB3,LEH4,LJT,LTA,L1,QA26,QE,QEH,QH2,QJW1,QMH,QPU,QSJ,QXC,SDB1,SDB3,SJC,SN,SSK1,S1,U1,VAX4,VH,VS,V1,WDJ,WJ1,W1
			(1)	(1)	-	-	3284617	3993725 DS,HHQ4,HTF2,HX,HX2,HX26,HX4,H1,LD,LH,LHQ4,LJ,LJD2,LSJ,LSJ4,LTJ,LTR,LX,LX2,LX26,LX4,PH,PM,PX,PX2,QA,QA2,QB26,QD,QH,QHQ4,QH26,QJG2,QLL,QM,QMA4,QMA8,QME4,QMX2,QT,QTC2,QX,QXC9,QXG2,QXS2,QX2,QX26,QX4,Q1,RD,RD4,RHC,RHQ4,RX,RX4,R1,SAJ,SCJ,SD,SD16,SD4,SE,SG24,SH,SHQ4,SJ,SJC1,SJC5,SKJ,SM7,SMJ,SMW2,SSK3,SSX4,STP,STS,SX,SX4,TH,TX,TX2,TX26,TX4,UH,UX,VED,VED1,VEE1,VET,VEX,VMS4,VPR4,VSX,VSX1,VX,VX4,WD12,WJ,WJP,WJP1,WKT2,WMA3,WME2,WM1
			(1)	-	-	-	3993725	HXU,LAJ4,LJC,LJS,LTK1,LXU,QWA4,QXU,SAJ4,SKR,SM11,SSX2,SWX2,SWX4,SXS4,UXU,VED6,VMT,VXU,WDA6,WKD6,WKT4,WME4
			-	-	(1)	-		QIH1,UIH
			-	-	-	(1)		
	13013-ZH7-003	RING SET, PISTON (0.75) (TEIKOKU)	(1)	(1)	-	-	3993726	AR,DKR,DS,HHQ4,HTF2,HX,HXU,HX2,HX26,HX4,H1,KR,KRA4,KRT,KRT4,KRT6,LAJ4,LD,LH,LHQ4,LJ,LJC,LJD2,LJS,LSJ,LSJ4,LTJ,LTK1,LTR,LX,LXU,LX2,LX26,LX4,PH,PM,PX,PX2,QA,QA2,QB26,QD,QH,QHQ4,QH26,QJG2,QLL,QM,QMA4,QMA8,QME4,QMX2,QT,QTC2,QWA4,QX,QXC9,QXG2,QXS2,QXU,QX2,QX26,QX4,Q1,RD,RD4,RHC,RHQ4,RX,RX4,R1,SAJ,SAJ4,SCJ,SD,SD16,SD4,SE,SG24,SH,SHQ4,SJ,SJC1,SJC5,SKJ,SKR,SM7,SMJ,SMW2,SM11,SSK3,SSX2,SSX4,STP,STS,SWX2,SWX4,SX,SXS4, SX4,TH,TX,TX2,TX26,TX4,UH,UX,UXU,VED,VED1,VED6,VEE1,VET,VEX,VMS4,VMT,VPR4,VSX,VSX1,VX,VXU,VX4,WDA6,WD12,WJ,WJP,WJP1,WKD6,WKT2,WKT4,WMA3,WME2,WME4,WM1
			(1)	-	-	-		HT2,KRF4,KRS4,LTS,QX7,SJD2,SM12,SM14,SX7,VEK,VEX7,VX7,WKT6

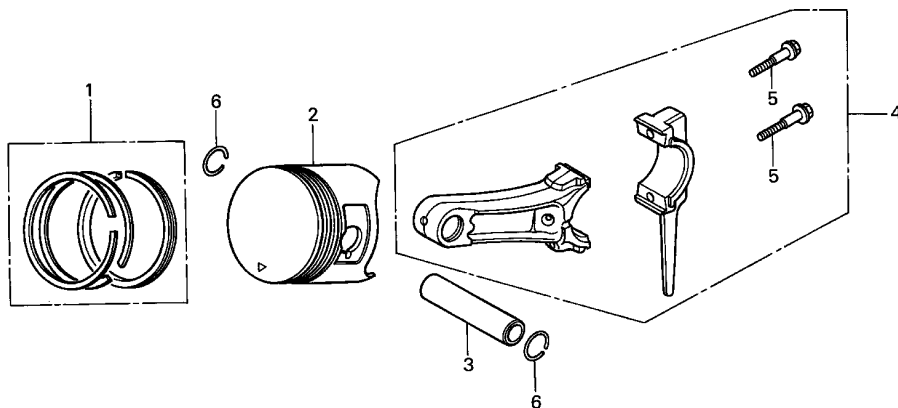

ZH70-E0800



2

Ref. No.	Part No.	Description	Reqd. QTY				Serial No.	Parts catalogue code
			(1)	(2)	(3)	(4)		
(1)	13013-ZH7-004	RING SET, PISTON (0.75) (NIPPON)	(1)	(1)	-	-	3993726	AR,DKR,DS,HHQ4,HTF2,HX,HXU,HX2,HX26,HX4,H1,KR,KRA4,KRT,KRT4,KRT6,LAJ4,LD,LH,LHQ4,LJ,LJC,LJD2,LJS,LSJ,LSJ4,LTJ,LTK1,LTR,LX,LXU,LX2,LX26,LX4,PH,PM,PX,PX2,QA,QA2,QB26,QD,QH,QHQ4,QH26,QJG2,QLL,QM,QMA4,QMA8,QME4,QMX2,QT,QTC2,QWA4,QX,QXC9,QXG2,QXS2,QXU,QX2,QX26,QX4,Q1,RD,RD4,RHC,RHQ4,RX,RX4,R1,SAJ,SAJ4,SCJ,SD,SD16,SD4,SE,SG24,SH,SHQ4,SJ,SJC1,SJC5,SKJ,SKR,SMA7,SMJ,SMW2,SM11,SSK3,SSX2,SSX4,STP,STS,SWX2,SWX4,SX,SXS4,SX4,TH,TX,TX2,TX26,TX4,UH,UX,UXU,VED,VED1,VED6,VEE1,VET,VEX,VMS4,VMT,VPR4,VSX,VSX1,VX,VXU,VX4,WDA6,WD12,WJ,WJP,WJP1,WKD6,WKT2,WKT4,WMA3,WME2,WME4,WM1
	13013-ZE6-013	.....	(1)	-	-	-	HT2,KRF4,KRS4,LTS,QX7,SJD2,SM12,SM14,SX7,VEK,VEX7,VX7,WKT6	
		.....	(1)	(1)	(1)	-	EN,ET,ETX,HH,LDB1,LD4,LE,LW2,PM2,QBU2,RH,SAD2,SW2,UIH,U1,VA,VH,VS1,V1	
		.....	(1)	(1)	-	-	3284616 HHQ4,HX,HX26,HX4,H1,LD,LDB3,LEH4,LH,LHQ4,LSJ4,LX,LX26,LX4,L1,PH,PM,PX,QA,QA26,QB26,QD,QE,QEH,QH,QHQ4,QH26,QLL,QM,QMA4,QMA8,QME4,QMH,QPU,QT,QX,QX26,QX4,Q1,RD,RD4,RHC,RHQ4,RX,RX4,R1,SD,SDB1,SDB3,SD16,SD4,SE,SH,SHQ4,SMA7,SN,SSX4,SX,SX4,S1,TH,TX,TX26,TX4,UH,UX,VAX4,VED,VED1,VEX,VMS4,VPR4,VS,VSX,VSX1,VX,VX4,WMA3,WM1,W1	
2	13101-ZF0-901	PISTON (STD.)	-	-	-	(1)	SN,UIH	

E-8

PISTON/CONNECTING ROD



Ref. No.	Part No.	Description	Reqd. QTY				Serial No.	Parts catalogue code
			(1)	GX120K1 (2)	(3)	(4)		
(2)	13101-ZH7-000	PISTON (STD.)	1	1	-	-	AR,DKR,EN,ET,ETX,HH,HHQ4,HXQ,HXU,HX4,KR,KRA4,KRT,KRT4,KRT6,LAJ4,LDB1,LDB3,LD4,LE,LEH4,LHQ4,LJC,LJD2,LJT,LSJ,LSJ4,LTA,LTK1,LW2,LXU,LX4,L1,PM2,QA2,QA26,QBU2,QB26,QE,QEH,QHQ4,QH2,QJG2,QJW1,QMA4,QMA8,QME4,QMH,QPU,QSJ,QWA4,QXC,QXG,QXQ,QXS,QXU,QX4,RD4,RH,RHQ4,RX4,SAD2,SAJ4,SDB1,SDB3,SD4,SHQ4,SJC,SJC5,SKR,SMA7,SSK1,SSK2,SW2,SXS4, SX4,S1, TX4,UXU,U1,VA,VAX4,VEE1,VH,VMS4,VMT,VPR4,VS,VS1,VXU,VX4,V1,WDJ,WD12,WJ1,WKT4,WMA3,WME4,WM1,W1	
			1	1	-	-	3993725 DS,HTF2,HX,HX2,HX26,H1,LD,LH,LJ,LJS,LJT,LTR,LX,LX2,LX26,PH,PX,PX2,QA,QA2,QD,QH,QH26,QLL,QMX2,QTC2,QX,QXC9,QXG2,QXS2,QX2,QX26,Q1,RD,RHC,RX,R1,SAJ,SCJ,SD,SD16,SE,SG24,SH,SJ,SJC1,SKJ,SMJ,SMW2,SSK3,SSX2,STP,STS,SWX2,SWX4, SX, TH, TX, TX2, TX26, UH, UX, VED, VED1, VED6, VEE1, VET, VEX, VMS4, VMT, VPR4, VSX, VSX1, VX, VXU, VX4, WDA6, WD12, WJ, WJP, WJP1, WKD6, WKT2, WKT4, WMA3, WME2, WME4, WM1	
	13102-ZH7-000	PISTON (0.25)	-	-	-	1	EN,ET,ETX,HH,HXQ,LDB1,LDB3,LD4,LE,LEH4,LJT,LTA,LW2,L1,PM,PM2,QA2,QA26,QBU2,QE,QEH,QH2,QJW1,QM,QMH,QPU,QSJ,QT,QXC,QXG,QXQ,QXS,RH,SAD2,SDB1,SDB3,SJC,SN,SSK1,SSK2,SW2,S1,UIH,U1,VA,VAX4,VH,VS,VS1,V1,WDJ,WJ1,W1	
			(1)	(1)	-	-	3993725 AR,DKR,DS,HHQ4,HTF2,HX,HXU,HX2,HX26,HX4,H1,KR,KRA4,KRT,KRT4,KRT6,LAJ4,LD,LH,LHQ4,LJ,LJC,LJD2,LJS,LSJ,LSJ4,LJT,LTK1,LTR,LX,LXU,LX2,LX26,LX4,PH,PX,PX2,QA,QA2,QB26,QD,QH,QHQ4,QH26,QJG2,QLL,QMA4,QMA8,QME4,QMX2,QTC2,QWA4,QX,QXC9,QXG2,QXS2,QXU,QX2,QX26,QX4,Q1,RD,RD4,RHC,RHQ4,RX,RX4,R1,SAJ,SAJ4,SCJ,SD,SD16,SD4,SE,SG24,SH,SHQ4,SJ,SJC1,SJC5,SKJ,SKR,SMA7,SMJ,SMW2,SSK3,SSX2,SSX4,STP,STS,SWX2,SWX4, SX, SXS4, SX4, TH, TX, TX2, TX26, TX4, UH, UX, UXU, VED, VED1, VED6, VEE1, VET, VEX, VMS4, VMT, VPR4, VSX, VSX1, VX, VXU, VX4, WDA6, WD12, WJ, WJP, WJP1, WKD6, WKT2, WKT4, WMA3, WME2, WME4, WM1	
	13103-ZH7-000	PISTON (0.50)	-	-	-	(1)	EN,ET,ETX,HH,HXQ,LDB1,LDB3,LD4,LE,LEH4,LJT,LTA,LW2,L1,PM,PM2,QA2,QA26,QBU2,QE,QEH,QH2,QJW1,QM,QMH,QPU,QSJ,QT,QXC,QXG,QXQ,QXS,RH,SAD2,SDB1,SDB3,SJC,SN,SSK1,SSK2,SW2,S1,UIH,U1,VA,VAX4,VH,VS,VS1,V1,WDJ,WJ1,W1	
			(1)	(1)	-	-	3993725 AR,DKR,DS,HHQ4,HTF2,HX,HXU,HX2,HX26,HX4,H1,KR,KRA4,KRT,KRT4,KRT6,LAJ4,LD,LH,LHQ4,LJ,LJC,LJD2,LJS,LSJ,LSJ4,LJT,LTK1,LTR,LX,LXU,LX2,LX26,LX4,PH,PX,PX2,QA,QA2,QB26,QD,QH,QHQ4,QH26,QJG2,QLL,QMA4,QMA8,QME4,QMX2,QTC2,QWA4,QX,QXC9,QXG2,QXS2,QXU,QX2,QX26,QX4,Q1,RD,RD4,RHC,RHQ4,RX,RX4,R1,SAJ,SAJ4,SCJ,SD,SD16,SD4,SE,SG24,SH,SHQ4,SJ,SJC1,SJC5,SKJ,SKR,SMA7,SMJ,SMW2,SSK3,SSX2,SSX4,STP,STS,SWX2,SWX4, SX, SXS4, SX4, TH, TX, TX2, TX26, TX4, UH, UX, UXU, VED, VED1, VED6, VEE1, VET, VEX, VMS4, VMT, VPR4, VSX, VSX1, VX, VXU, VX4, WDA6, WD12, WJ, WJP, WJP1, WKD6, WKT2, WKT4, WMA3, WME2, WME4, WM1	
	13104-ZH7-000	PISTON (0.75)	-	-	-	(1)	EN,ET,ETX,HH,HXQ,LDB1,LDB3,LD4,LE,LEH4,LJT,LTA,LW2,L1,PM,PM2,QA2,QA26,QBU2,QE,QEH,QH2,QJW1,QM,QMH,QPU,QSJ,QT,QXC,QXG,QXQ,QXS,RH,SAD2,SDB1,SDB3,SJC,SN,SSK1,SSK2,SW2,S1,UIH,U1,VA,VAX4,VH,VS,VS1,V1,WDJ,WJ1,W1	
			(1)	(1)	-	-	3993725 AR,DKR,DS,HHQ4,HTF2,HX,HXU,HX2,HX26,HX4,H1,KR,KRA4,KRT,KRT4,KRT6,LAJ4,LD,LH,LHQ4,LJ,LJC,LJD2,LJS,LSJ,LSJ4,LJT,LTK1,LTR,LX,LXU,LX2,LX26,LX4,PH,PX,PX2,QA,QA2,QB26,QD,QH,QHQ4,QH26,QJG2,QLL,QMA4,QMA8,QME4,QMX2,QTC2,QWA4,QX,QXC9,QXG2,QXS2,QXU,QX2,QX26,QX4,Q1,RD,RD4,RHC,RHQ4,RX,RX4,R1,SAJ,SAJ4,SCJ,SD,SD16,SD4,SE,SG24,SH,SHQ4,SJ,SJC1,SJC5,SKJ,SKR,SMA7,SMJ,SMW2,SSK3,SSX2,SSX4,STP,STS,SWX2,SWX4, SX, SXS4, SX4, TH, TX, TX2, TX26, TX4, UH, UX, UXU, VED, VED1, VED6, VEE1, VET, VEX, VMS4, VMT, VPR4, VSX, VSX1, VX, VXU, VX4, WDA6, WD12, WJ, WJP, WJP1, WKD6, WKT2, WKT4, WMA3, WME2, WME4, WM1	
	13101-ZF0-020	PISTON (E=7.5)	1	-	1	-	PM,QIH1,QM,QT	
	13101-ZF0-902	PISTON (STD.)	-	-	1	-	WIH1	









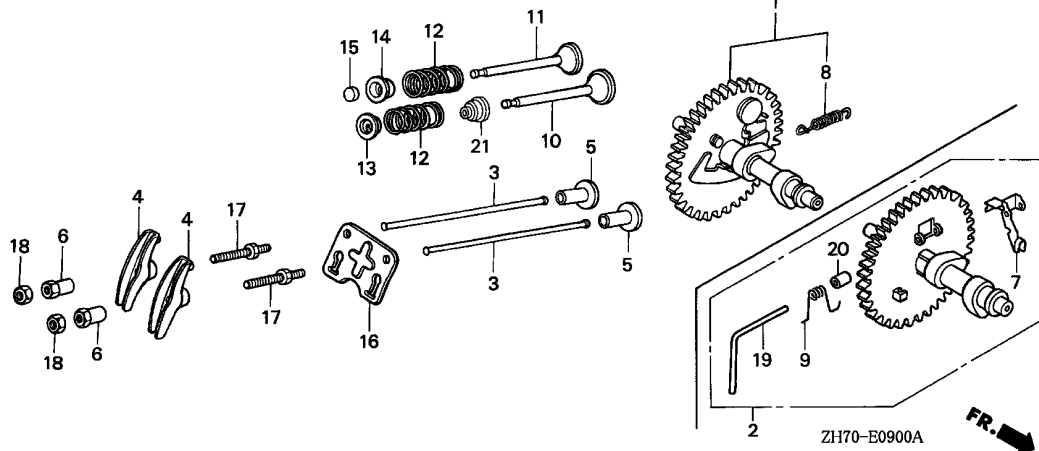

Ref. No.	L.O.N.	(Relative ref. Number) Description	F.R.T.
1		(2)	
1	1111C2	CAMSHAFT ..... .INCLUDES: Valve clearance adjustment	0.4
3	1111L6	ROD, PUSH :INTAKE ..... .INCLUDES: Valve clearance adjustment	0.2
	1111L6A	.For one add .....	0.1
	1111L7	ROD, PUSH :EXHAUST ..... .INCLUDES: Valve clearance adjustment	0.2
	1111L7A	.For one add .....	0.1
4	1111A2	ARM, ROCKER :INTAKE ..... .INCLUDES: Valve clearance adjustment	0.2
	1111A2A	.With exhaust rocker arm add ..	0.1
	1111A1	ARM, ROCKER :EXHAUST ..... .INCLUDES: Valve clearance adjustment	0.2
	1111A1A	.With intake rocker arm add ..	0.1
5	1111L9	LIFTER, VALVE :INTAKE ..... .NOTE: Same time for two units	0.4
	1111M0	LIFTER, VALVE :EXHAUST ..... .NOTE: Same time for two units	0.4
+10	1111L1	VALVE, INTAKE .....	0.7

Ref. No.	Part No.	Description	Reqd. QTY				Serial No.	Parts catalogue code			
			(1)	(2)	(3)	(4)					
1	14100-ZE0-812	CAMSHAFT ASSY. ....	1	-	-	-	DS,EN,ET,ETX,HH,HHQ4,HTF2,HT2,HX,HXQ,HXU,HX2,HX26,HX4,LAJ4,LD,LDB1,LDB3,LD4,LE,LEH4,LH,LHQ4,LJ,LJC,LJD2,LJS,LJT,LSJ,LSJ4,LTA,LTJ, LTK1,LTR,LTS,LW2,LX,LXU,LX2,LX26,LX4,PH,PM2,PX,PX2,QA,QAA2,QA2,QA26,QBU2,QB26,QD,QE,QEH,QH,QHQ4,QH2,QH26,QJG2,QJW1,QLL,QMA4,QMA8,QME4,QMH,QMX2,QPU,QSJ,QTC2,QWA4,QX,QXC,QXC9,QXG,QXG2,QXQ,QXS,QXS2,QXU,QX2,QX26,QX4,RD,RD4,RH,RHC,RHQ4,RX,RX4,SAD2,SAJ,SAJ4,SCJ,SD,SDB1,SDB3,SD16,SD4,SE,SG24,SH,SHQ4,SJ,SJD2,SKJ,SKR,SMA7,SMJ,SMW2,SM11,SM12,SM14,SSK1,SSK2,SSK3,SSX2,SSX4,STP,STS,SWX2,SWX4,SW2,SX,SXS4,SX4,TH,TX,TX2,TX26,TX4,UH,UX,UXU,VA,VAX4,VED,VED1,VED6,VEE1,VEK,VET,VEX,VH,VMS4,VMT,VPR4,VS,VSX,VSX1,VS1,VX,VXU,VX4,WDA6,WDJ,WD12,WJ,WJP,WJP1,WKD6,WKT2,WKT4,WKT6,WMA3,WME2,WME4				
	14100-ZF0-000	.....	-	1	-	1	PM,QM,QT,SJC,SJC1,SJC5,SN				
	14100-ZH7-B20	.....	1	-	-	-	AR,DKR,KR,KRA4,KRF4,KRS4,KRT,KRT4,KRT6				
	14100-ZK7-870	.....	1	-	-	-	QX7,SX7,VEX7,VX7				
2	14100-ZK7-800	CAMSHAFT ASSY. ....	1	-	-	-	WJ1,WM1				
3	14410-ZE0-010	ROD, PUSH .....	2	2	2	2					
4	14431-ZE1-000	ARM, VALVE ROCKER .....	2	2	2	2					

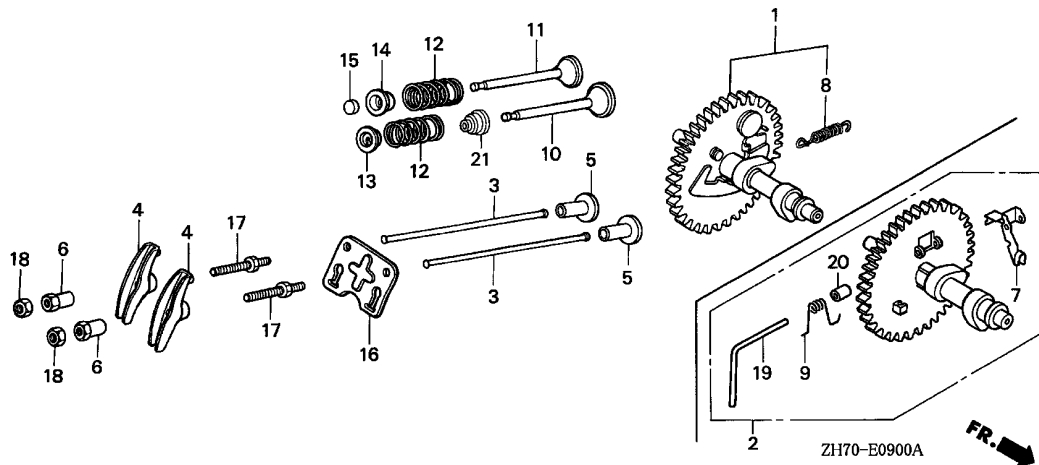

Ref. No.	L.O.N.	(Relative ref. Number) Description	F.R.T.
+10		.INCLUDES: Valve clearance adjustment and reface	
	1111L1E	.With intake and exhaust all add .....	0.1
11	1111L0	VALVE, EXHAUST .....	0.7
		.INCLUDES: Valve clearance adjustment and reface	
	1111LOE	.With intake and exhaust all add .....	0.1
12	1111P3	SPRING, VALVE :INTAKE .....	0.6
		.INCLUDES: Valve clearance adjustment	
	1111P3A	.For one add .....	0.1
	1111P4	SPRING, VALVE :EXHAUST .....	0.6
		.INCLUDES: Valve clearance adjustment	
	1111P4A	.For one add .....	0.1
15	1111J7	ROTATOR, VALVE .....	0.2
		.INCLUDES: Valve clearance adjustment	
21	1111K2	SEAL, INTAKE VALVE STEM .....	0.6
		.INCLUDES: Valve clearance adjustment	

Ref. No.	Part No.	Description	Reqd. QTY				Serial No.	Parts catalogue code
			(1)	(2)	(3)	(4)		
5	14441-ZE1-000	LIFTER, VALVE .....	2	2	-	-	2828018	DKR,DS,EN,ET,ETX,HH,HHQ4,HTF2,HX,HXQ,HX2,HX26,HX4,H1,KR,KRT,LD,LDB1,LDB3,LD4,LE,LH,LHQ4,LJ,LTA,LTJ,LTR,LW2,LX,LX2,LX26,LX4,L1,PH,PM,PM2,PX,PX2,QA,QAA2,QA2,QA26,QBU2,QD,QE,QEH,QH,QHQ4,QH2,QH26,QLL,QM,QMA4,QMA8,QME4,QMX2,QPU,QSJ,QT,QTC2,QX,QXC,QXC9,QXG,QXG2,QXQ,QXS,QXS2,QX2,QX26,QX4,Q1,RD,RD4,RH,RHC,RHQ4,RX,RX4,R1,SAD2,SAJ,SCJ,SD,SDB1,SDB3,SD16,SD4,SE,SG24,SH,SHQ4,SJ,SJC,SKJ,SMA7,SMJ,SMW2,SN,SSK1,SSK2,SSK3,SSX4,STP,STS,SW2,SX,SX4,S1,TH,TX,TX2,TX26,TX4,UH,UX,VA,VAX4,VED,VED1,VET,VEX,VH,VS,VSX,VSX1,VS1,VX,VX4,V1,WDJ,WJ,WJP,WJP1,WKT2,WMA3,WME2,W1
	14441-ZE1-010	.....	-	2	-	-	2828019	U1 DKR,DS,EN,ET,ETX,HH,HHQ4,HTF2,HX,HXQ,HX2,HX26,HX4,H1,KR,KRT,LD,LDB1,LDB3,LD4,LE,LH,LHQ4,LJ,LTA,LTJ,LTR,LW2,LX,LX2,LX26,LX4,L1,PH,PM,PM2,PX,PX2,QA,QAA2,QA2,QA26,QBU2,QD,QE,QEH,QH,QHQ4,QH2,QH26,QLL,QM,QMA4,QMA8,QME4,QMX2,QPU,QSJ,QT,QTC2,QX,QXC,QXC9,QXG,QXG2,QXQ,QXS,QXS2,QX2,QX26,QX4,Q1,RD,RD4,RH,RHC,RHQ4,RX,RX4,R1,SAD2,SAJ,SCJ,SD,SDB1,SDB3,SD16,SD4,SE,SG24,SH,SHQ4,SJ,SJC,SKJ,SMA7,SMJ,SMW2,SN,SSK1,SSK2,SSK3,SSX4,STP,STS,SW2,SX,SX4,S1,TH,TX,TX2,TX26,TX4,UH,UX,VA,VAX4,VED,VED1,VET,VEX,VH,VS,VSX,VSX1,VS1,VX,VX4,V1,WDJ,WJ,WJP,WJP1,WKT2,WMA3,WME2,W1
			2	-	-	-	-----	AR,HT2,HXU,KRA4,KRF4,KRS4,KRT4,KRT6,LAJ4,LEH4,LJC,LJD2,LJS,LJT,LSJ,LSJ4,LTK1,LTS,LXU,QB26,QJG2,QJW1,QMH,QWA4,QXU,QX7,SAJ4,SJC1,SJC5,SJD2,SKR,SM11,SM12,SM14,SSX2,SWX2,SWX4,SXS4, SX7,UXU,VED6,VEE1,VEK,VEX7,VMS4,VMT,VPR4,VXU,VX7,WDA6,WD12,WJ1,WKD6,WKT4,WKT6,WME4,WM1
			-	-	2	2		



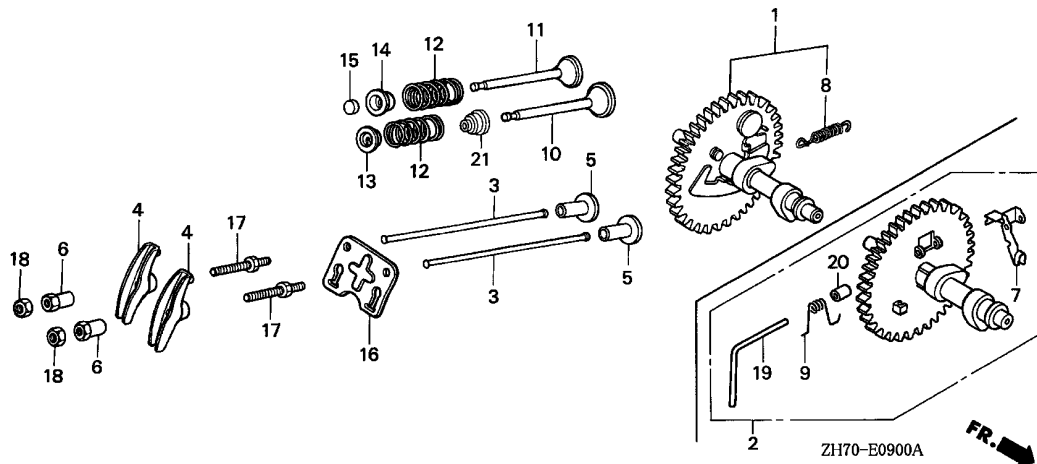

2

Ref. No.	Part No.	Description	Reqd. QTY				Serial No.	Parts catalogue code
			(1)	GX120K1 (2)	(3)	(4)		
6	14451-ZE1-003	PIVOT, ROCKER ARM .....	2	-	2	-	DS,EN,ET,ETX,HH,HXU,LD,LE,LH,LJ,LTA,LW2,LX,LXU,PH,PM,PM2,PX,QD QE,QEH,QH,QM,QSJ,QT,QXU,RD,RH,RX,SD,SE,SH,SJ,SKJ,SMJ,SN,STS SW2,SX,TH,UH,UIH,UX,UXU,VA,VED,VED1,VET,VH,VS,VSX,VS1,VX,VXU WJ 2257853 HX,HXQ,HX2,LX2,QA,QA2,QH2,QX,QXC,QXG,QXG2,QXQ,QXS,QXS2,QX2,TX TX2	
	14451-ZE1-013	.....	-	2	-	2	AR,DKR,HHQ4,HTF2,HT2,HX26,HX4,KR,KRA4,KRF4,KRS4,KRT,KRT4,KRT6 LAJ4,LDB1,LDB3,LD4,LEH4,LHQ4,LJC,LJD2,LJS,LJT,LSJ,LSJ4,LTJ LTK1,LTR,LTS,LX26,LX4,PX2,QAA2,QA26,QBU2,QB26,QHQ4,QH26,QIH1 QJG2,QJW1,QLL,QMA4,QMA8,QME4,QMH,QMX2,QPU,QTC2,QWA4,QXC9,QX26 QX4,QX7,RD4,RHC,RHQ4,RX4,SAD2,SAJ,SAJ4,SCJ,SDB1,SDB3,SD16,SD4 SG24,SHQ4,SJC,SJC1,SJC5,SJD2,SKR,SMA7,SMW2,SM11,SM12,SM14,SSK1 SSK2,SSK3,SSX2,SSX4,STP,SWX2,SWX4,SXS4,SX4,SX7,TX26,TX4,VAX4 VED6,VEE1,VEK,VEX,VEX7,VMS4,VMT,VPR4,VSX1,VX4,VX7,WDA6,WDJ WD12,WIH1,WJP,WJP1,WJ1,WKD6,WKT2,WKT4,WKT6,WMA3,WME2,WME4,WM1 2257854 HX,HXQ,HX2,LX2,QA,QA2,QH2,QX,QXC,QXG,QXG2,QXQ,QXS,QXS2,QX2,TX TX2	
7	14560-ZK7-800	WEIGHT COMP., DECOMPER .....	1	-	-	-	WJ1,WM1	

Ref. No.	Part No.	Description	Reqd. QTY				Serial No.	Parts catalogue code
			(1)	GX120K1 (2)	(3)	(4)		
8	14568-ZE1-000	SPRING, WEIGHT RETURN .....	1	-	-	-	AR,DKR,DS,EN,ET,ETX,HH,HHQ4,HTF2,HT2,HX,HXQ,HXU,HX2,HX26,HX4 KR,KRA4,KRF4,KRS4,KRT,KRT4,KRT6,LAJ4,LD,LDB1,LDB3,LD4,LE,LEH4 LH,LHQ4,LJ,LJC,LJD2,LJS,LJT,LSJ,LSJ4,LTA,LTJ,LTK1,LTR,LTS,LW2 LX,LXU,LX2,LX26,LX4,PH,PM,PM2,PX,PX2,QA,QAA2,QA2,QA26,QBU2 QB26,QD,QE,QEH,QH,QHQ4,QH2,QH26,QJG2,QJW1,QLL,QM,QMA4,QMA8 QME4,QMH,QMX2,QPU,QSJ,QT,QTC2,QWA4,QX,QXC,QXC9,QXG,QXG2,QXQ QXS,QXS2,QXU,QX2,QX26,QX4,QX7,RD,RD4,RH,RHC,RHQ4,RX,RX4,SAD2 SAJ,SAJ4,SCJ,SD,SDB1,SDB3,SD16,SD4,SE,SG24,SH,SHQ4,SJ,SJC,SJC1 SJC5,SJD2,SKJ,SKR,SMA7,SMJ,SMW2,SM11,SM12,SM14,SN,SSK1,SSK2 SSK3,SSX2,SSX4,STP,STS,SWX2,SWX4,SW2,SX,SXS4,SX4,SX7,TH,TX,TX2 TX26,TX4,UH,UX,UXU,VA,VAX4,VED,VED1,VED6,VEE1,VEK,VET,VEX,VEX7 VH,VMS4,VMT,VPR4,VS,VSX,VSX1,VS1,VX,VXU,VX4,VX7,WDA6,WDJ,WD12 WJ,WJP,WJP1,WKD6,WKT2,WKT4,WKT6,WMA3,WME2,WME4	
9	14568-ZG9-800	SPRING, WEIGHT RETURN .....	-	1	1	1		
10	14711-ZF0-000	VALVE, IN. ....	1	-	-	-	WJ1,WM1	
	14711-ZF0-010	.....	1	-	-	-	AR,DKR,DS,EN,ET,ETX,HH,HHQ4,HTF2,HX,HXQ,HXU,HX2,HX26,HX4,KR KRA4,KRT,KRT4,KRT6,LAJ4,LD,LDB1,LDB3,LD4,LE,LEH4,LH,LHQ4,LJ LJC,LJD2,LJS,LJT,LSJ,LSJ4,LTA,LTJ,LTK1,LTR,LW2,LX,LXU,LX2,LX26 LX4,PH,PM,PM2,PX,PX2,QA,QAA2,QA2,QA26,QBU2,QB26,QD,QE,QEH,QH QHQ4,QH2,QH26,QJG2,QJW1,QLL,QM,QMA4,QMA8,QME4,QMH,QMX2,QPU,QSJ QT,QTC2,QWA4,QX,QXC,QXC9,QXG,QXG2,QXQ,QXS,QXS2,QXU,QX2,QX26 QX4,RD,RD4,RH,RHC,RHQ4,RX,RX4,SAD2,SAJ,SAJ4,SCJ,SD,SDB1,SDB3 SD16,SD4,SE,SG24,SH,SHQ4,SJ,SJC,SJC1,SJC5,SKJ,SKR,SMA7,SMJ SMW2,SN,SSK1,SSK2,SSK3,SSX2,SSX4,STP,STS,SWX2,SWX4,SW2,SX,SXS4 SX4,TH,TX,TX2,TX26,TX4,UH,UX,UXU,VA,VAX4,VED,VED1,VED6,VEE1 VET,VEX,VH,VMS4,VMT,VPR4,VS,VSX,VSX1,VS1,VX,VXU,VX4,WDA6,WDJ WD12,WJ,WJP,WJP1,WJ1,WKD6,WKT2,WKT4,WMA3,WME2,WME4,WM1	
	14721-ZE0-810	VALVE, EX. (STELITE) .....	-	(1)	-	-	H1,Q1,R1,U1,V1,W1	
	14721-ZF0-000	VALVE, EX. ....	1	-	-	-	AR,DKR,DS,EN,ET,ETX,HH,HHQ4,HTF2,HT2,HX,HXQ,HXU,HX2,HX26,HX4 KR,KRA4,KRF4,KRS4,KRT,KRT4,KRT6,LAJ4,LD,LDB1,LDB3,LD4,LE,LEH4 LH,LHQ4,LJ,LJC,LJD2,LJS,LJT,LSJ,LSJ4,LTA,LTJ,LTK1,LTR,LTS,LW2 LX,LXU,LX2,LX26,LX4,PM,PM2,QA,QAA2,QA2,QA26,QBU2,QB26,QD,QE QEH,QH,QHQ4,QH2,QH26,QJG2,QJW1,QLL,QM,QMA4,QMA8,QME4,QMH,QMX2 QPU,QSJ,QT,QTC2,QWA4,QX,QXC,QXC9,QXG,QXG2,QXQ,QXS,QXS2,QXU,QX2 QX26,QX4,QX7,RD,RD4,RH,RHC,RHQ4,RX,RX4,SAD2,SAJ,SAJ4,SCJ,SD SDB1,SDB3,SD16,SD4,SE,SG24,SH,SHQ4,SJ,SJC,SJC1,SJC5,SJD2,SKJ SKR,SMA7,SMJ,SMW2,SM11,SM12,SM14,SN,SSK1,SSK2,SSK3,SSX2,SSX4 STP,STS,SWX2,SWX4,SW2,SX,SXS4,SX4,SX7,VA,VAX4,VED,VED1,VED6 VEE1,VEK,VET,VEX,VEX7,VH,VMS4,VMT,VPR4,VS,VSX,VSX1,VS1,VX,VXU VX4,VX7,WDA6,WDJ,WD12,WJ,WJP,WJP1,WJ1,WKD6,WKT2,WKT4,WKT6,WMA3 WME2,WME4,WM1	
	14721-ZH7-810	VALVE, EX. (STELLITE) .....	-	(1)	1	-	PH,PX,PX2,TH,TX,TX2,TX26,TX4,UH,UX,UXU	
12	14751-ZF1-000	SPRING, VALVE .....	2	2	2	2		
13	14771-ZE1-000	RETAINER, IN. VALVE SPRING ..	1	1	1	1		
14	14773-ZE1-000	RETAINER, EX. VALVE SPRING ..	1	1	1	1		
15	14781-ZE1-000	ROTATOR, VALVE .....	1	1	1	1		
16	14791-ZE0-010	PLATE, PUSH ROD GUIDE .....	1	1	1	1		
17	90012-ZE0-010	BOLT, PIVOT, 8MM .....	2	2	2	2		
18	90206-ZE1-000	NUT, PIVOT ADJUSTING .....	2	2	2	2		
19	90701-ZG9-800	PIN, WEIGHT CENTER .....	1	-	-	-	WJ1,WM1	
20	91502-ZG9-800	COLLAR, WEIGHT CENTER .....	1	-	-	-	WJ1,WM1	



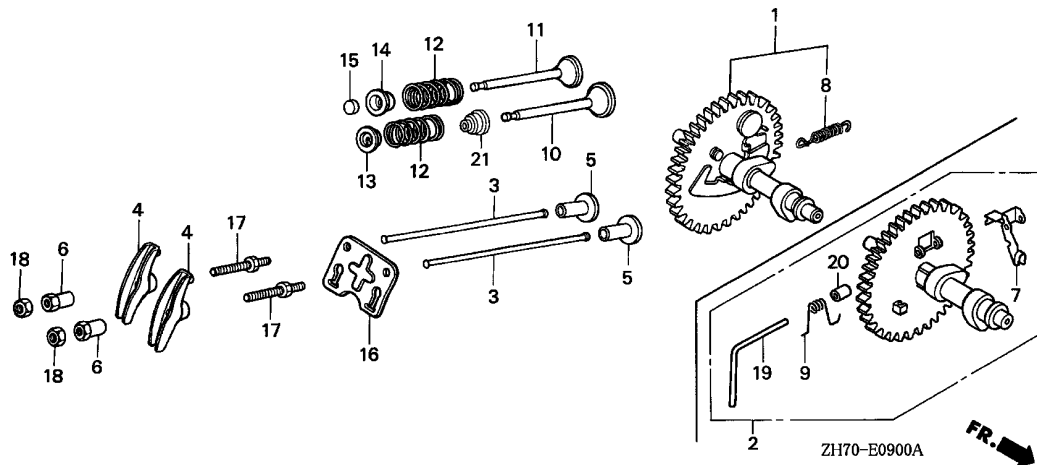

2

Ref. No.	Part No.	Description	Reqd. QTY				Serial No.	Parts catalogue code
			(1)	(2)	(3)	(4)		
			GX120K1					
21	12209-ZH8-003	SEAL, VALVE STEM .....	1	1	-	-	3993726 -----	AR,DKR,DS,HHQ4,HTF2,HX,HXU,HX2,HX26,HX4,H1,KR,KRA4,KRT,KRT4 KRT6,LAJ4,LD,LH,LHQ4,LJ,LJC,LJD2,LJS,LSJ,LSJ4,LTJ,LTK1,LTR,LX LXU,LX2,LX26,LX4,PH,PM,PX,PX2,QA,QA2,QB26,QD,QH,QHQ4,QH26,QJG2 QLL,QM,QMA4,QMA8,QME4,QMX2,QT,QTC2,QWA4,QX,QXC9,QXG2,QXS2,QXU QX2,QX26,QX4,Q1,RD,RD4,RHC,RHQ4,RX,RX4,R1,SAJ,SAJ4,SCJ,SD,SD16 SD4,SE,SG24,SH,SHQ4,SJ,SJC1,SJC5,SKJ,SKR,SMA7,SMJ,SMW2,SM11 SSK3,SSX2,SSX4,STP,STS,SWX2,SWX4,SX,SXS4,SX4,TH,TX,TX2,TX26 TX4,UH,UX,UXU,VED,VED1,VED6,VEE1,VET,VEX,VMS4,VMT,VPR4,VSX VSX1,VX,VXU,VX4,WDA6,WD12,WJ,WJP,WJP1,WKD6,WKT2,WKT4,WMA3,WME2 WME4,WM1 HT2,KRF4,KRS4,LTS,QX7,SJD2,SM12,SM14,SX7,VEK,VEX7,VX7,WKT6

E-11

RECOIL STARTER(1)

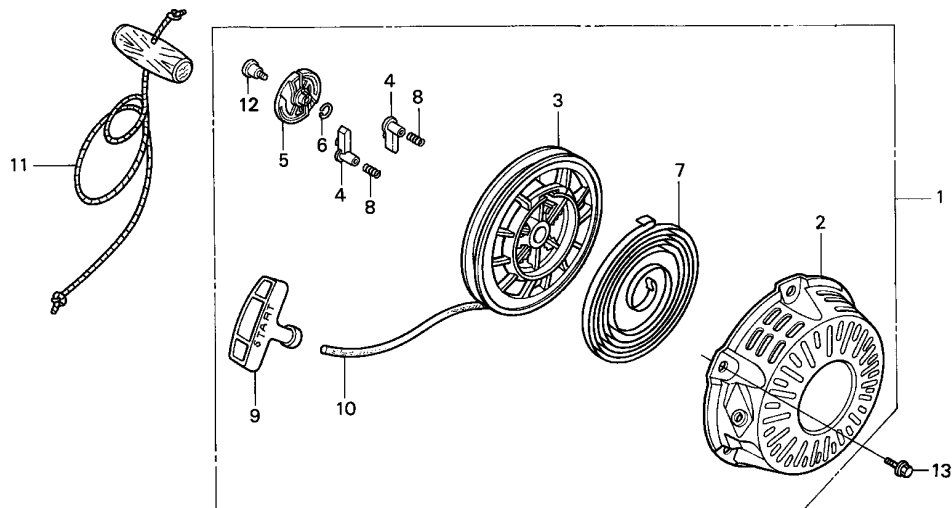

ZH70-E1100

Ref. No.	L.O.N.	(Relative ref. Number) Description	F.R.T.
1	1121B9	STARTER, RECOIL .....	0.1
3	1121B1	REEL, RECOIL STARTER .....	0.3
4	1121B0	RATCHET, STARTER AND/OR SPRING, RATCHET .....	0.2
5	1121A4	GUIDE, RATCHET .....	0.2
7	1121B7	SPRING, RECOIL STARTER RETURN (11) .....	0.3
10	1121B3	ROPE, RECOIL STARTER .....	0.3

Ref. No.	Part No.	Description	Reqd. QTY				Serial No.	Parts catalogue code	
			(1)	(2)	(3)	(4)			
1	28400-ZH8-013ZA	STARTER ASSY., RECOIL *R8*.....BRIGHT RED	1	(1)	-	-	EN,ET,ETX,HH,HXQ,LDB1,LDB3,LD4,LE,LEH4,LJT,LTA,LW2,LX26,PH,PM,PM2,QA2,QA26,QBU2,QE,QUEH,QH2,QJW1,QMH,QPU,QSJ,QTC2,QWA4,QXC,QXG,QXG2,QXQ,QXS,RH,SAD2,SDB1,SDB3,SJC,SKJ,SKR,SN,SW2,S1,TH,UH,UX,U1,VA,VAX4,VH,VMT,VS,VS1,V1,WDJ,WJ1,WM1,W1		
			1	(1)	-	-	4142273	AR,DKR,DS,HHQ4,HTF2,HT2,HX,HXU,HX2,HX26,HX4,H1,KR,KRA4,KRF4,KRS4,KRT,KRT4,KRT6,LD,LH,LHQ4,LJ,LJC,LJS,LSJ,LSJ4,LTJ,LTK1,LTR,LX,LXU,LX2,LX4,L1,PX,QA,QA2,QD,QH,QHQ4,QH26,QLL,QM,QMA4,QMA8,QME4,QMX2,QX,QXC9,QXS2,QXU,QX2,QX26,QX4,QX7,Q1,RD,RD4,RHC,RHQ4,RX,RX4,R1,SAJ,SAJ4,SCJ,SD,SD16,SD4,SE,SH,SHQ4,SJ,SJC1,SJC5,SMA7,SMJ,SMW2,STP,STS,SX,SXS4,SX4,SX7,TX,TX2,TX26,TX4,UXU,VED,VED1,VET,VEX,VEX7,VMS4,VPR4,VSX,VSX1,VX,VXU,VX4,VX7,WDA6,WD12,WJ,WJP,WKD6,WKT2,WKT4,WKT6,WMA3,WME2,WME4	
			1	-	-	-	2169650	3463997	QT
	28400-ZH8-013YA	*R280*.....POWER RED	1	(1)	-	-	4142274	AR,DKR,DS,HHQ4,HTF2,HT2,HX,HXU,HX2,HX26,HX4,H1,KR,KRA4,KRF4,KRS4,KRT,KRT4,KRT6,LD,LH,LHQ4,LJ,LJC,LJS,LSJ,LSJ4,LTJ,LTK1,LTR,LX,LXU,LX2,LX4,L1,PX,QA,QA2,QD,QH,QHQ4,QH26,QLL,QM,QMA4,QMA8,QME4,QMX2,QX,QXC9,QXS2,QXU,QX2,QX26,QX4,QX7,Q1,RD,RD4,RHC,RHQ4,RX,RX4,R1,SAJ,SAJ4,SCJ,SD,SD16,SD4,SE,SH,SHQ4,SJ,SJC1,SJC5,SMA7,SMJ,SMW2,STP,STS,SX,SXS4,SX4,SX7,TX,TX2,TX26,TX4,UXU,VED,VED1,VET,VEX,VEX7,VMS4,VPR4,VSX,VSX1,VX,VXU,VX4,VX7,WDA6,WD12,WJ,WJP,WKD6,WKT2,WKT4,WKT6,WMA3,WME2,WME4	
	28400-ZH8-013ZB	*NH1*.....BLACK	1	-	-	-			LTS
			1	-	-	-			AR,HXQ,HX2,KR,LX2,PX2,QA2,QH2,QMX2,QWA4,QXC9,QXG2,QXQ,QXS2,QX2,SG24,SM11,SM12,SM14,SSK1,SSK2,SSK3,SSX2,SSX4,TX2,TX4,VED1,VED6,VEE1,VSX
	28400-ZH8-013ZG	*NH105*...MAT BLACK (#15-#20)	1	-	-	-	2242263		QX,TX
			1	-	-	-			LJD2,QJG2,SJD2,SWX2,SWX4





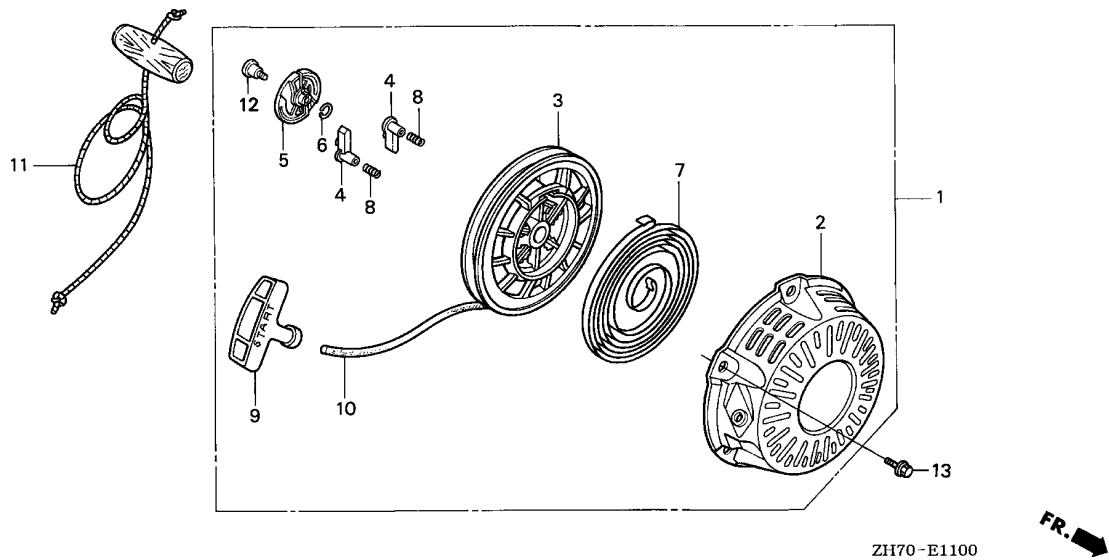

Ref. No.	Part No.	Description	Reqd. QTY				Serial No.	Parts catalogue code
			(1)	(2)	(3)	(4)		
(1)	28400-ZH8-013ZJ	STARTER ASSY., RECOIL						
		*T51*.....JACOBSEN ORANGE	1	-	-	-	----- QJG2,QXG2	
			1	-	-	2243557	----- QXG	
	28400-ZH8-013ZK	*NH31*.....MCKINLEY WHITE	1	-	-	-----	----- VEK	
	28400-ZH8-013ZM	*NH246*.....LOOSEY GRAY	1	-	-	-----	----- VPR4	
	28400-ZH8-013ZQ	*Y131*.....LIGHTNING YELLOW	1	-	-	-----	----- VSX1	
	28400-ZH8-013ZS	*T76*.....IRIS GREEN	1	-	-	-----	----- WJP1	
	28400-ZH8-013ZT	*T77*.....SEC WINE RED	1	-	-	-----	----- VSX,VSX1	
	28400-ZH8-013ZV	*T79*.....BOMBARDIER YELLOW	1	-	-	-----	----- QB26	
	28400-ZH8-013ZW	*T80*.....BAKELITE ORANGE	1	-	-	3892283	----- VSX,VSX1	
	28400-ZH8-R10ZA	STARTER ASSY., RECOIL (TURFCO)						
		*R8*.....BRIGHT RED	1	-	-	-----	----- LAJ4	
2	28410-ZH8-003ZA	CASE COMP., RECOIL STARTER						
		*R8*.....BRIGHT RED	1	(1)	-	-----	----- EN,ET,ETX,HH,HXQ,LDB1,LDB3,LD4,LE,LEH4,LJT,LTA,LW2,LX26,PH,PM	
							----- PM2,QAA2,QA26,QBU2,QE,QEH,QH2,QJW1,QMH,QPU,QSJ,QTC2,QWA4,QXC	
							----- QXG,QXG2,QXQ,QXS,RH,SAD2,SDB1,SDB3,SJC,SKJ,SKR,SN,SW2,S1,TH,UH	
							----- UX,U1,VA,VAX4,VH,VMT,VS,VS1,V1,WDJ,WJ1,WM1,W1	
			1	(1)	-	4142273	----- AR,DKR,DS,HHQ4,HTF2,HT2,HX,HXU,HX2,HX26,HX4,H1,KR,KRA4,KRF4	
							----- KRS4,KRT,KRT4,KRT6,LAJ4,LD,LH,LHQ4,LJ,LJC,LJS,LSJ,LSJ4,LTJ	
							----- LTK1,LTR,LX,LXU,LX2,LX4,L1,PX,QA,QA2,QD,QH,QHQ4,QH26,QLL,QM	
							----- QMA4,QMA8,QME4,QMX2,QX,QXC9,QXS2,QXU,QX2,QX26,QX4,QX7,Q1,RD	
							----- RD4,RHC,RHQ4,RX,RX4,R1,SAJ,SAJ4,SCJ,SD,SD16,SD4,SE,SH,SHQ4,SJ	
							----- SJC1,SJC5,SMA7,SMJ,SMW2,STP,STS,SX,SXS4,SX4,SX7,TX,TX2,TX26	
							----- TX4,UXU,VED,VED1,VET,VEX,VEX7,VMS4,VPR4,VSX,VSX1,VX,VXU,VX4	
							----- VX7,WDA6,WD12,WJ,WJP,WKD6,WKT2,WKT4,WKT6,WMA3,WME2,WME4	
			1	-	-	3463997	----- QT	
			-	-	1	1		

Ref. No.	Part No.	Description	Reqd. QTY				Serial No.	Parts catalogue code	
			(1)	GX120K1 (2)	(3)	(4)			
(2)	28410-ZH8-003ZB	CASE COMP., RECOIL STARTER *NH1*.....BLACK	1	-	-	-	-----	AR, HXQ, HX2, KR, LX2, PX2, QA2, QH2, QMX2, QWA4, QXC9, QXG2, QXQ, QXS2, QX2 SG24, SM11, SM12, SM14, SSK1, SSK2, SSK3, SSS2, SSS4, TX2, TX4, VED1, VED6 VEE1, VSX	
	28410-ZH8-003ZG	*NH105*...MAT BLACK (#15-#20)	1	-	-	-	2242263	-----	QX, TX
	28410-ZH8-003ZJ	*T51*.....JACOBSEN ORANGE	1	-	-	-	-----	-----	LJD2, QJG2, SJD2, SWX2, SWX4
	28410-ZH8-003ZK	*NH31*.....MCKINLEY WHITE	1	-	-	-	2243557	-----	QJG2, QXG2
	28410-ZH8-003ZM	*NH246*.....LOOSEY GRAY	1	-	-	-	-----	-----	QXG
	28410-ZH8-003ZQ	*Y131*.....LIGHTNING YELLOW	1	-	-	-	-----	-----	VEK
	28410-ZH8-003ZS	*T76*.....IRIS GREEN	1	-	-	-	-----	-----	VPR4
	28410-ZH8-003ZT	*T77*.....SEC WINE RED	1	-	-	-	-----	-----	VSX1
	28410-ZH8-003ZV	*T79*.....BOMBARDIER YELLOW	1	-	-	-	-----	-----	WJP1
	28410-ZH8-003ZW	*T80*.....BAKELITE ORANGE	1	-	-	-	-----	-----	VSX, VSX1
	28410-ZH8-003YA	*R280*.....POWER RED	1	(1)	-	-	3892283	-----	QB26
			1	(1)	-	-	4142274	-----	VSX, VSX1
			1	-	-	-	-----	-----	AR, DKR, DS, HHQ4, HTF2, HT2, HX, HXU, HX2, HX26, HX4, H1, KR, KRA4, KRF4 KRS4, KRT, KRT4, KRT6, LAJ4, LD, LH, LHQ4, LJ, LJC, LJS, LSJ, LSJ4, LTJ LTK1, LTR, LX, LXU, LX2, LX4, L1, PX, QA, QA2, QD, QH, QHQ4, QH26, QLL, QM QMA4, QMA8, QME4, QMX2, QX, QXC9, QXS2, QXU, QX2, QX26, QX4, QX7, Q1, RD RD4, RHC, RHQ4, RX, RX4, R1, SAJ, SAJ4, SCJ, SD, SD16, SD4, SE, SH, SHQ4, SJ SJC1, SJC5, SMA7, SMJ, SMW2, STP, STS, SX, SXS4, SX4, SX7, TX, TX2, TX26 TX4, UXU, VED, VED1, VET, VEX, VEX7, VMS4, VPR4, VSX, VSX1, VX, VXU, VX4 VX7, WDA6, WD12, WJ, WJP, WKD6, WKT2, WKT4, WKT6, WMA3, WME2, WME4
3	28420-ZH8-003	REEL, RECOIL STARTER (BLACK)	1	-	-	-	2169649	-----	LTS
	28420-ZH8-013	REEL, RECOIL STARTER (NATURAL)	1	(1)	-	-	2169649	-----	DS, EN, ET, ETX, HH, HX, LD, LE, LH, LJ, LW2, LX, PH, PM, PM2, PX, QA, QD, QE, QH QM, QSJ, QT, QX, QXC, QXG, QXS, RD, RH, RX, SD, SE, SH, SJ, SMJ, SN, STS, SW2 SX, TH, TX, UH, UX, VA, VED, VED1, VET, VH, VS, VSX, VX, WJ
			1	-	-	-	2169650	-----	AR, DKR, HHQ4, HTF2, HT2, HXQ, HXU, HX2, HX26, HX4, KR, KRA4, KRF4, KRS4 KRT, KRT4, KRT6, LAJ4, LDB1, LDB3, LD4, LEH4, LHQ4, LJC, LJD2, LJS, LJT LSJ, LSJ4, LTA, LTJ, LTK1, LTR, LTS, LXU, LX2, LX26, LX4, PX2, QAA2, QA2 QA26, QBU2, QB26, QEH, QHQ4, QH2, QH26, QJG2, QJW1, QLL, QMA4, QMA8, QME4 QMH, QMX2, QPU, QTC2, QWA4, QXC9, QXG2, QXQ, QXS2, QXU, QX2, QX26, QX4, QX7 RD4, RHC, RHQ4, RX4, SAD2, SAJ, SAJ4, SCJ, SDB1, SDB3, SD16, SD4, SG24 SHQ4, SJC, SJC1, SJC5, SJD2, SKJ, SKR, SMA7, SMW2, SM11, SM12, SM14, SSK1 SSK2, SSK3, SSS2, SSS4, STP, SWX2, SWX4, SXS4, SX4, SX7, TX2, TX26, TX4 UXU, VAX4, VED6, VEE1, VEK, VEX, VEX7, VMS4, VMT, VPR4, VSX1, VS1, VXU, VX4 VX7, WDA6, WDJ, WD12, WJP, WJP1, WJ1, WKD6, WKT2, WKT4, WKT6, WMA3, WME2 WME4, WM1
			1	-	-	-	2169650	-----	DS, EN, ET, ETX, HH, HX, LD, LE, LH, LJ, LW2, LX, PH, PM, PM2, PX, QA, QD, QE, QH QM, QSJ, QX, QXC, QXG, QXS, RD, RH, RX, SD, SE, SH, SJ, SMJ, SN, STS, SW2, SX TH, TX, UH, UX, VA, VED, VED1, VET, VH, VS, VSX, VX, WJ
			1	-	-	-	2169650	-----	QT
			-	(1)	-	-	2169650	-----	QT
4	28422-ZH8-003	RATCHET, STARTER .....	2	-	-	-	2169649	-----	DS, EN, ET, ETX, HH, HX, LD, LE, LH, LJ, LW2, LX, PH, PM, PM2, PX, QA, QD, QE, QH QM, QSJ, QT, QX, QXC, QXG, QXS, RD, RH, RX, SD, SE, SH, SJ, SMJ, SN, STS, SW2 SX, TH, TX, UH, UX, VA, VED, VED1, VET, VH, VS, VSX, VX, WJ
			-	(2)	-	-	2169649	-----	DS, EN, ET, ETX, HH, HX, LD, LE, LH, LJ, LW2, LX, PH, PM, PM2, PX, QA, QD, QE, QH QM, QSJ, QT, QX, QXC, QXG, QXS, RD, RH, RX, SD, SE, SH, SJ, SMJ, SN, STS, SW2 SX, TH, TX, UH, UX, VA, VED, VED1, VET, VH, VS, VSX, VX, WJ



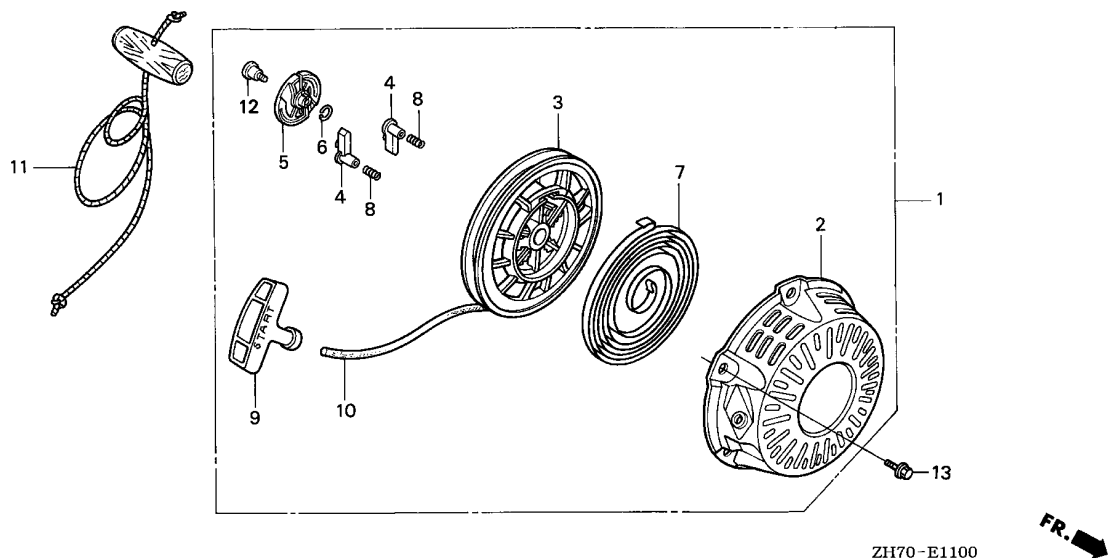

2

Ref. No.	Part No.	Description	Reqd. QTY				Serial No.	Parts catalogue code					
			(1)	GX120K1 (2)	(3)	(4)							
(4)	28422-ZH8-013	RATCHET, STARTER .....	2	-	-	-	AR,DKR,HHQ4,HTF2,HT2,HXQ,HXU,HX2,HX26,HX4,KR,KRA4,KRF4,KRS4 KRT,KRT4,KRT6,LAJ4,LDB1,LDB3,LD4,LEH4,LHQ4,LJC,LJD2,LJS,LJT LSJ,LSJ4,LTA,LTJ,LTK1,LTR,LTS,LXU,LX2,LX26,LX4,PX2,QAA2,QA2 QA26,QBU2,QB26,QEH,QHQ4,QH2,QH26,QJG2,QJW1,QLL,QMA4,QMA8,QME4 QMH,QMX2,QPU,QTC2,QWA4,QXC9,QXG2,QXQ,QXS2,QXU,QX2,QX26,QX4,QX7 RD4,RHC,RHQ4,RX4,SAD2,SAJ,SAJ4,SCJ,SDB1,SDB3,SD16,SD4,SG24 SHQ4,SJC,SJC1,SJC5,SJD2,SKJ,SKR,SMA7,SMW2,SM11,SM12,SM14,SSK1 SSK2,SSK3,SSX2,SSX4,STP,SWX2,SWX4,SXS4,SX4,SX7,TX2,TX26,TX4 UXU,VAX4,VED6,VEE1,VEK,VEX,VEX7,VMS4,VMT,VPR4,VSX1,VS1,VXU,VX4 VX7,WDA6,WDJ,WD12,WJP,WJP1,WJ1,WKD6,WKT2,WKT4,WKT6,WMA3,WME2 WME4,WM1	2	-	-	-	2169650	DS,EN,ET,ETX,HH,HX,LD,LE,LH,LJ,LW2,LX,PH,PM,PM2,PX,QA,QD,QE,QH QM,QSJ,QX,QXC,QXG,QXS,RD,RH,RX,SD,SE,SH,SJ,SMJ,SN,STS,SW2,SX TH,TX,UH,UX,VA,VED,VED1,VET,VH,VS,VSX,VX,WJ
			2	-	-	-	2169650	3463997 QT					
			-	(2)	-	-	2169650						
			-	-	2	2							

Ref. No.	Part No.	Description	Reqd. QTY				Serial No.	Parts catalogue code
			(1)	GX120K1 (2)	(3)	(4)		
5	28433-ZH8-003	GUIDE, RATCHET .....	1	-	-	-	-----	AR,DKR,DS,EN,ET,ETX,HH,HHQ4,HTF2,HT2,HX,HXQ,HXU,HX2,HX26,HX4 KR,KRA4,KRF4,KRS4,KRT,KRT4,KRT6,LAJ4,LD,LDB1,LDB3,LD4,LE,LEH4 LH,LHQ4,LJ,LJC,LJD2,LJS,LJT,LSJ,LSJ4,LTA,LTJ,LTK1,LTR,LTS,LW2 LX,LXU,LX2,LX26,LX4,PH,PM,PM2,PX,PX2,QA,QAA2,QA2,QA26,QBU2 QB26,QD,QE,QEH,QH,QHQ4,QH2,QH26,QJG2,QJW1,QLL,QM,QMA4,QMA8 QME4,QMH,QMX2,QPU,QSJ,QTC2,QWA4,QX,QXC,QXC9,QXG,QXG2,QXQ,QXS QXS2,QXU,QX2,QX26,QX4,QX7,RD,RD4,RH,RHC,RHQ4,RX,RX4,SAD2,SAJ SAJ4,SCJ,SD,SDB1,SDB3,SD16,SD4,SE,SG24,SH,SHQ4,SJ,SJC,SJC1 SJC5,SJD2,SKJ,SKR,SMA7,SMJ,SMW2,SM11,SM12,SM14,SN,SSK1,SSK2 SSK3,SSX2,SSX4,STP,STS,SWX2,SWX4,SW2,SX,SXS4, SX4, SX7, TH, TX, TX2 TX26, TX4, UH, UX, UXU, VA, VAX4, VED, VED1, VED6, VEE1, VEK, VET, VEX, VEX7 VH, VMS4, VMT, VPR4, VS, VSX, VSX1, VS1, VX, VXU, VX4, VX7, WDA6, WDJ, WD12 WJ, WJP, WJP1, WJ1, WKD6, WKT2, WKT4, WKT6, WMA3, WME2, WME4, WM1
			1	-	-	-	-----	3463997 QT
			-	(1)	1	1		
6	28441-ZH8-003	SPRING, FRICTION .....	1	-	-	-	-----	AR,DKR,DS,EN,ET,ETX,HH,HHQ4,HTF2,HT2,HX,HXQ,HXU,HX2,HX26,HX4 KR,KRA4,KRF4,KRS4,KRT,KRT4,KRT6,LAJ4,LD,LDB1,LDB3,LD4,LE,LEH4 LH,LHQ4,LJ,LJC,LJD2,LJS,LJT,LSJ,LSJ4,LTA,LTJ,LTK1,LTR,LTS,LW2 LX,LXU,LX2,LX26,LX4,PH,PM,PM2,PX,PX2,QA,QAA2,QA2,QA26,QBU2 QB26,QD,QE,QEH,QH,QHQ4,QH2,QH26,QJG2,QJW1,QLL,QM,QMA4,QMA8 QME4,QMH,QMX2,QPU,QSJ,QTC2,QWA4,QX,QXC,QXC9,QXG,QXG2,QXQ,QXS QXS2,QXU,QX2,QX26,QX4,QX7,RD,RD4,RH,RHC,RHQ4,RX,RX4,SAD2,SAJ SAJ4,SCJ,SD,SDB1,SDB3,SD16,SD4,SE,SG24,SH,SHQ4,SJ,SJC,SJC1 SJC5,SJD2,SKJ,SKR,SMA7,SMJ,SMW2,SM11,SM12,SM14,SN,SSK1,SSK2 SSK3,SSX2,SSX4,STP,STS,SWX2,SWX4,SW2,SX,SXS4, SX4, SX7, TH, TX, TX2 TX26, TX4, UH, UX, UXU, VA, VAX4, VED, VED1, VED6, VEE1, VEK, VET, VEX, VEX7 VH, VMS4, VMT, VPR4, VS, VSX, VSX1, VS1, VX, VXU, VX4, VX7, WDA6, WDJ, WD12 WJ, WJP, WJP1, WJ1, WKD6, WKT2, WKT4, WKT6, WMA3, WME2, WME4, WM1
			1	-	-	-	-----	3463997 QT
			-	(1)	1	1		
7	28442-ZH8-003	SPRING, RECOIL STARTER .....	1	-	-	-	-----	AR,DKR,DS,EN,ET,ETX,HH,HHQ4,HTF2,HT2,HX,HXQ,HXU,HX2,HX26,HX4 KR,KRA4,KRF4,KRS4,KRT,KRT4,KRT6,LAJ4,LD,LDB1,LDB3,LD4,LE,LEH4 LH,LHQ4,LJ,LJC,LJD2,LJS,LJT,LSJ,LSJ4,LTA,LTJ,LTK1,LTR,LTS,LW2 LX,LXU,LX2,LX26,LX4,PH,PM,PM2,PX,PX2,QA,QAA2,QA2,QA26,QBU2 QB26,QD,QE,QEH,QH,QHQ4,QH2,QH26,QJG2,QJW1,QLL,QM,QMA4,QMA8 QME4,QMH,QMX2,QPU,QSJ,QTC2,QWA4,QX,QXC,QXC9,QXG,QXG2,QXQ,QXS QXS2,QXU,QX2,QX26,QX4,QX7,RD,RD4,RH,RHC,RHQ4,RX,RX4,SAD2,SAJ SAJ4,SCJ,SD,SDB1,SDB3,SD16,SD4,SE,SG24,SH,SHQ4,SJ,SJC,SJC1 SJC5,SJD2,SKJ,SKR,SMA7,SMJ,SMW2,SM11,SM12,SM14,SN,SSK1,SSK2 SSK3,SSX2,SSX4,STP,STS,SWX2,SWX4,SW2,SX,SXS4, SX4, SX7, TH, TX, TX2 TX26, TX4, UH, UX, UXU, VA, VAX4, VED, VED1, VED6, VEE1, VEK, VET, VEX, VEX7 VH, VMS4, VMT, VPR4, VS, VSX, VSX1, VS1, VX, VXU, VX4, VX7, WDA6, WDJ, WD12 WJ, WJP, WJP1, WJ1, WKD6, WKT2, WKT4, WKT6, WMA3, WME2, WME4, WM1
			1	-	-	-	-----	3463997 QT
			-	(1)	1	1		



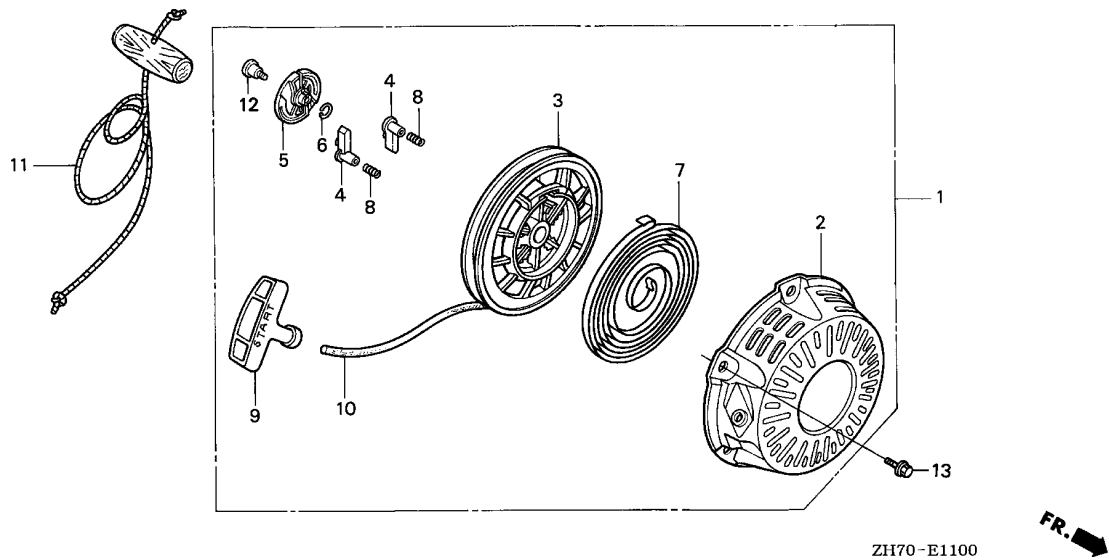

ZH70-E1100



Ref. No.	Part No.	Description	Reqd. QTY				Serial No.	Parts catalogue code					
			(1)	(2)	(3)	(4)							
8	28443-ZH8-003	SPRING, RETURN .....	2	-	-	-	AR,DKR,DS,EN,ET,ETX,HH,HHQ4,HTF2,HT2,HX,HXQ,HXU,HX2,HX26,HX4 KR,KRA4,KRF4,KRS4,KRT,KRT4,KRT6,LAJ4,LD,LDB1,LDB3,LD4,LE,LEH4 LH,LHQ4,LJ,LJC,LJD2,LJS,LJT,LSJ,LSJ4,LTA,LTJ,LTK1,LTR,LTS,LW2 LX,LXU,LX2,LX26,LX4,PH,PM,PM2,PX,PX2,QA,QAA2,QA2,QA26,QBU2 QB26,QD,QE,QEH,QH,QHQ4,QH2,QH26,QJG2,QJW1,QLL,QM,QMA4,QMA8 QME4,QMH,QMX2,QPU,QSJ,QTC2,QWA4,QX,QXC,QXC9,QXG,QXG2,QXQ,QXS QXS2,QXU,QX2,QX26,QX4,QX7,RD,RD4,RH,RHC,RHQ4,RX,RX4,SAD2,SAJ SAJ4,SCJ,SD,SDB1,SDB3,SD16,SD4,SE,SG24,SH,SHQ4,SJ,SJC,SJC1 SJC5,SJD2,SKJ,SKR,SMA7,SMJ,SMW2,SM11,SM12,SM14,SN,SSK1,SSK2 SSK3,SSX2,SSX4,STP,STS,SWX2,SWX4,SW2,SX,SXS4,SX4, SX7,TH,TX,TX2 TX26,TX4,UH,UX,UXU,VA,VAX4,VED,VED1,VED6,VEE1,VEK,VET,VEX,VEX7 VH,VMS4,VMT,VPR4,VS,VSX,VSX1,VS1,VX,VXU,VX4,VX7,WDA6,WDJ,WD12 WJ,WJP,WJP1,WJ1,WKD6,WKT2,WKT4,WKT6,WMA3,WME2,WME4,WM1	2	-	-	-	3463997 QT	
			-	(2)	2	2							

Ref. No.	Part No.	Description	Reqd. QTY				Serial No.	Parts catalogue code
			(1)	GX120K1 (2)	(3)	(4)		
9	28461-ZH8-003	GRIP, STARTER .....	1	-	-	-	-----	AR,DKR,DS,EN,ET,ETX,HH,HHQ4,HTF2,HT2,HX,HXQ,HXU,HX2,HX26,HX4,KR,KRA4,KRF4,KRS4,KRT,KRT4,KRT6,LAJ4,LD,LDB1,LDB3,LD4,LE,LEH4,LH,LHQ4,LJ,LJC,LJD2,LJS,LJT,LSJ,LSJ4,LTA,LTJ,LTK1,LTR,LTS,LW2,LX,LXU,LX2,LX26,LX4,PH,PM,PM2,PX,PX2,QA,QAA2,QA2,QA26,QBU2,QB26,QD,QE,QEH,QH,QHQ4,QH2,QH26,QJG2,QJW1,QLL,QM,QMA4,QMA8,QME4,QMH,QMX2,QPU,QSJ,QTC2,QWA4,QX,QXC,QXC9,QXG,QXG2,QXQ,QXS,QXS2,QXU,QX2,QX26,QX4,QX7,RD,RD4,RH,RHC,RHQ4,RX,RX4,SAD2,SAJ,SAJ4,SCJ,SD,SDB1,SDB3,SD16,SD4,SE,SG24,SH,SHQ4,SJ,SJC,SJC1,SJC5,SJD2,SKJ,SKR,SMA7,SMJ,SMW2,SM11,SM12,SM14,SN,SSK1,SSK2,SSK3,SSX2,SSX4,STP,STS,SWX2,SWX4,SW2,SX,SXS4,SX4,SX7,TH,TX,TX2,TX26,TX4,UH,UX,UXU,VA,VAX4,VED,VED1,VED6,VEE1,VEK,VET,VEX,VEX7,VH,VMS4,VMT,VPR4,VS,VSX,VSX1,VS1,VX,VXU,VX4,VX7,WDA6,WDJ,WD12,WJ,WJP,WJP1,WJ1,WKD6,WKT2,WKT4,WKT6,WMA3,WME2,WME4,WM1
			1	-	-	-	-----	3463997 QT
			-	(1)	1	1		
10	28462-ZH8-003	ROPE, RECOIL STARTER .....	1	-	-	-	-----	AR,DKR,DS,EN,ET,ETX,HH,HHQ4,HTF2,HT2,HX,HXQ,HXU,HX2,HX26,HX4,KR,KRA4,KRF4,KRS4,KRT,KRT4,KRT6,LD,LDB1,LDB3,LD4,LE,LEH4,LH,LHQ4,LJ,LJC,LJD2,LJS,LJT,LSJ,LSJ4,LTA,LTJ,LTK1,LTR,LTS,LW2,LX,LXU,LX2,LX26,LX4,PH,PM,PM2,PX,PX2,QA,QAA2,QA2,QA26,QBU2,QB26,QD,QE,QEH,QH,QHQ4,QH2,QH26,QJG2,QJW1,QLL,QM,QMA4,QMA8,QME4,QMH,QMX2,QPU,QSJ,QTC2,QWA4,QX,QXC,QXC9,QXG,QXG2,QXQ,QXS,QXS2,QXU,QX2,QX26,QX4,QX7,RD,RD4,RH,RHC,RHQ4,RX,RX4,SAD2,SAJ,SAJ4,SCJ,SD,SDB1,SDB3,SD16,SD4,SE,SG24,SH,SHQ4,SJ,SJC,SJC1,SJC5,SJD2,SKJ,SKR,SMA7,SMJ,SMW2,SM11,SM12,SM14,SN,SSK1,SSK2,SSK3,SSX2,SSX4,STP,STS,SWX2,SWX4,SW2,SX,SXS4,SX4,SX7,TH,TX,TX2,TX26,TX4,UH,UX,UXU,VA,VAX4,VED,VED1,VED6,VEE1,VEK,VET,VEX,VEX7,VH,VMS4,VMT,VPR4,VS,VSX,VSX1,VS1,VX,VXU,VX4,VX7,WDA6,WDJ,WD12,WJ,WJP,WJP1,WJ1,WKD6,WKT2,WKT4,WKT6,WMA3,WME2,WME4,WM1
			1	-	-	-	-----	3463997 QT
	28462-ZH8-R10	.....	1	-	-	-	-----	LAJ4
11	28470-816-000	ROPE, STARTER .....	1	-	-	-	-----	DS,HX,LD,LJ,LX,PH,PX,QD,QSJ,QX,RD,RX,SD,SJ,SMJ,STS,SX,TH,UH,UX,VET,VH,VX,WJ
12	90003-ZH8-003	SCREW, SETTING .....	1	-	-	-	-----	AR,DKR,DS,EN,ET,ETX,HH,HHQ4,HTF2,HT2,HX,HXQ,HXU,HX2,HX26,HX4,KR,KRA4,KRF4,KRS4,KRT,KRT4,KRT6,LAJ4,LD,LDB1,LDB3,LD4,LE,LEH4,LH,LHQ4,LJ,LJC,LJD2,LJS,LJT,LSJ,LSJ4,LTA,LTJ,LTK1,LTR,LTS,LW2,LX,LXU,LX2,LX26,LX4,PH,PM,PM2,PX,PX2,QA,QAA2,QA2,QA26,QBU2,QB26,QD,QE,QEH,QH,QHQ4,QH2,QH26,QJG2,QJW1,QLL,QM,QMA4,QMA8,QME4,QMH,QMX2,QPU,QSJ,QTC2,QWA4,QX,QXC,QXC9,QXG,QXG2,QXQ,QXS,QXS2,QXU,QX2,QX26,QX4,QX7,RD,RD4,RH,RHC,RHQ4,RX,RX4,SAD2,SAJ,SAJ4,SCJ,SD,SDB1,SDB3,SD16,SD4,SE,SG24,SH,SHQ4,SJ,SJC,SJC1,SJC5,SJD2,SKJ,SKR,SMA7,SMJ,SMW2,SM11,SM12,SM14,SN,SSK1,SSK2,SSK3,SSX2,SSX4,STP,STS,SWX2,SWX4,SW2,SX,SXS4,SX4,SX7,TH,TX,TX2,TX26,TX4,UH,UX,UXU,VA,VAX4,VED,VED1,VED6,VEE1,VEK,VET,VEX,VEX7,VH,VMS4,VMT,VPR4,VS,VSX,VSX1,VS1,VX,VXU,VX4,VX7,WDA6,WDJ,WD12,WJ,WJP,WJP1,WJ1,WKD6,WKT2,WKT4,WKT6,WMA3,WME2,WME4,WM1
			1	-	-	-	-----	3463997 QT
			-	(1)	1	1		
13	95701-06008-00	BOLT, FLANGE, 6X8 .....	3	(3)	-	-	-----	EN,ET,ETX,HH,HXQ,LDB1,LDB3,LD4,LE,LJT,LTA,LW2,L1,PM2,QAA2,QA26,QBU2,QE,QH2,QJW1,QMH,QPU,QSJ,QXC,QXG,QXQ,QXS,RH,SAD2,SCJ,SDB1,SSK1,SSK2,SW2,U1,VA,VAX4,VH,VS,VSX,VSX1,V1,WDJ,WJ1,W1
			3	-	-	-	-----	3463997 QT



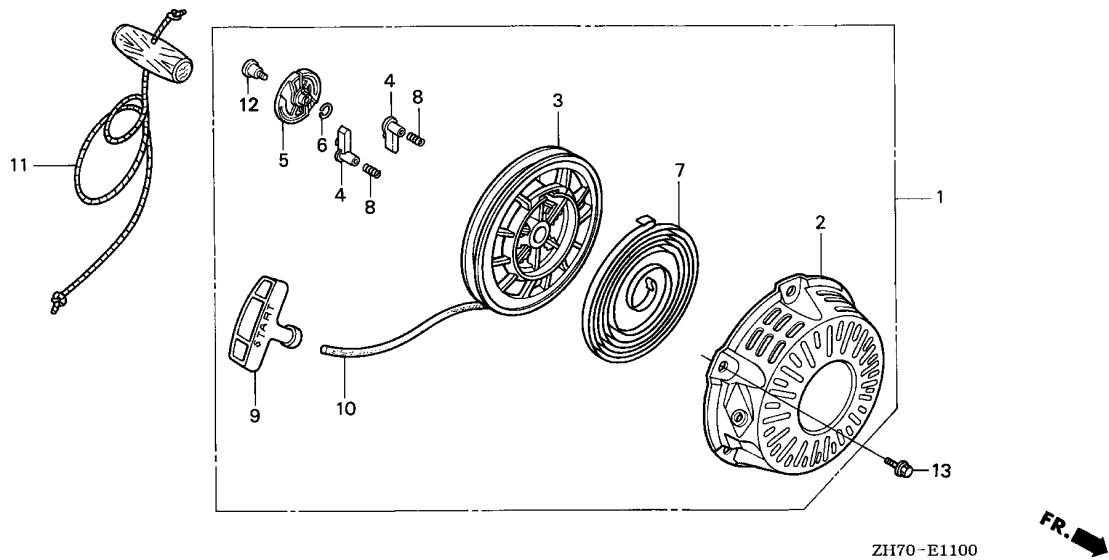

ZH70-E1100

Ref. No.	Part No.	Description	Reqd. QTY				Serial No.	Parts catalogue code			
			(1)	(2)	(3)	(4)					
13)	90008-ZE2-003	BOLT, FLANGE, 6X10	3	(3)	-	-	AR,DKR,DS,HHQ4,HTF2,HT2,HX,HXU,HX2,HX26,HX4,H1,KR,KRA4,KRF4,KRS4,KRT,KRT4,KRT6,LAJ4,LD,LEH4,LH,LHQ4,LJ,LJC,LJD2,LJS,LSJ,LSJ4,LTJ,LTK1,LTR,LTS,LX,LXU,LX2,LX26,LX4,PH,PM,PX,PX2,QA,QA2,QB26,QD,QEH,QH,QHQ4,QH26,QJG2,QLL,QM,QMA4,QMA8,QME4,QMX2,QTC2,QWA4,QX,QXC9,QXG2,QXS2,QXU,QX2,QX26,QX4,QX7,Q1,RD,RD4,RHC,RHQ4,RX,RX4,R1,SAJ,SAJ4,SD,SDB3,SD16,SD4,SE,SG24,SH,SHQ4,SJ,SJC,SJC1,SJC5,SJD2,SKJ,SKR,SMA7,SMJ,SMW2,SM11,SM12,SM14,SN,SSK3,SSX2,SSX4,STP,STS,SWX2,SWX4,SX,SXS4,SX4,SX7,S1,TH,TX,TX2,TX26,TX4,UH,UX,UXU,VED,VED1,VED6,VEE1,VEK,VET,VEX,VEX7,VMS4,VMT,VPR4,VX,VXU,VX4,VX7,WDA6,WD12,WJ,WJP,WJP1,WKD6,WKT2,WKT4,WKT6,WMA3,WME2,WME4,WM1,W1	-	-	3	3

E-11-1

RECOIL STARTER(2)

G15

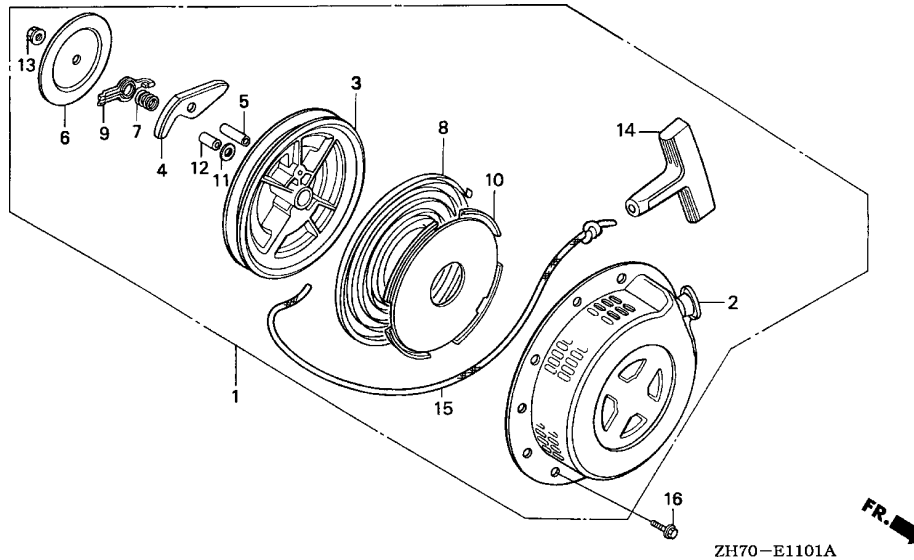

Ref. No.	L.O.N.	(Relative ref. Number) Description	F.R.T.
1	1121B9	STARTER, RECOIL .....	0.1
3	1121C9	REEL, RECOIL STARTER(A) .....	0.4
4	1121B0	RATCHET, STARTER AND/OR SPRING, RATCHET .....	0.2
8	1121D1	SPRING, RECOIL STARTER RETURN (A) .....	0.4
15	1121D0	ROPE, RECOIL STARTER(A) .....	0.4

Ref. No.	Part No.	Description	Reqd. QTY				Serial No.	Parts catalogue code
			(1)	(2)	(3)	(4)		
1	28400-ZE1-003ZA	STARTER ASSY., RECOIL *R8*.....BRIGHT RED	1	-	-	-	3463998	----- QT
2	28410-ZE1-003ZA	CASE COMP., RECOIL STARTER *R8*.....BRIGHT RED	1	-	-	-	3463998	----- QT
3	28420-ZE1-003	PULLEY, RECOIL STARTER .....	1	-	-	-	3463998	----- QT
4	28422-ZE1-003	RATCHET, STARTER .....	1	-	-	-	3463998	----- QT
5	28423-ZE1-003	PIN, STARTER RATCHET .....	1	-	-	-	3463998	----- QT
6	28431-ZE1-003	PLATE, FRICTION .....	1	-	-	-	3463998	----- QT
7	28441-ZE1-003	SPRING, FRICTION .....	1	-	-	-	3463998	----- QT
8	28442-ZE1-003	SPRING, RECOIL STARTER .....	1	-	-	-	3463998	----- QT
9	28443-ZE1-003	GUIDE, RATCHET .....	1	-	-	-	3463998	----- QT
10	28445-ZE1-003	CASE, RECOIL STARTER SPRING ..	1	-	-	-	3463998	----- QT
11	28446-ZE1-003	WASHER, STARTER .....	1	-	-	-	3463998	----- QT
12	28447-ZE1-003	SHAFT, SUB .....	1	-	-	-	3463998	----- QT
13	28448-ZE1-003	NUT .....	1	-	-	-	3463998	----- QT
14	28461-ZE1-003	KNOB, RECOIL STARTER .....	1	-	-	-	3463998	----- QT
15	28462-ZE1-003	ROPE, RECOIL STARTER .....	1	-	-	-	3463998	----- QT
16	90008-ZE2-003	BOLT, FLANGE, 6X10 .....	3	-	-	-	3463998	----- QT

2



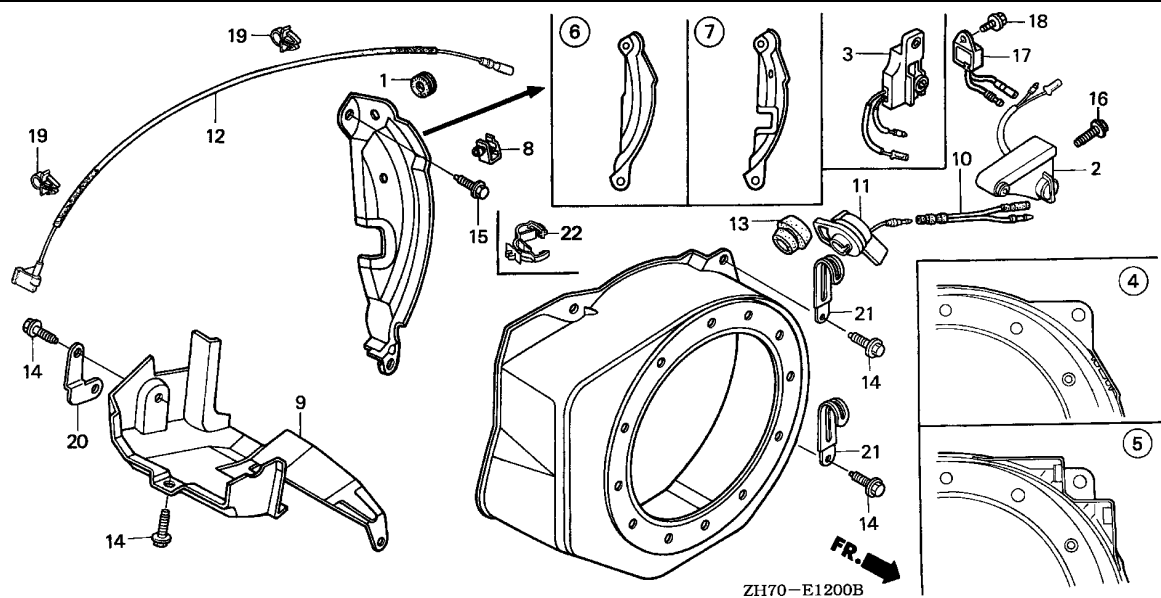

Ref. No.	L.O.N.	(Relative ref. Number) Description	F.R.T.
2	6151C6	(3) SWITCH, OIL ALERT UNIT .....	0.1
4	1141G8	(5) COVER, ENGINE COOLING FAN ....	0.2
6	1121A7	(7) PLATE, SIDE .....	0.3
9	4141E0	SHROUD, ENGINE :LOWER .....	0.1
10	6111A3	CORD, ENGINE STOP SWITCH .....	0.1
11	6151D9	SWITCH, ENGINE STOP .....	0.3
12	6111B3	CORD, STOP SWITCH .....	0.3
17	6151A0	ALERT UNIT, OIL .....	0.1



Ref. No.	Part No.	Description	Reqd. QTY				Serial No.	Parts catalogue code
			(1)	(2)	(3)	(4)		
1	11347-371-300	GROMMET, ADJUSTING COVER ....	1	1	1	1		
2	15520-ZE1-003	ALERT UNIT, OIL .....	1	-	-	-	2186369 HX,LX,PX,QX,QXC,QXG,QXS,RX,SMJ,SX,UX,VA,VED1,VSX,VX	
3	15520-ZE1-822	ALERT UNIT, OIL .....	-	(1)	-	-	2186369 ETX	
4	19610-ZB0-601ZB	COVER COMP., FAN	1	-	-	-	4162941 LSJ4,SJC1,SJC5	
	19610-ZE0-000ZA	*R8*.....BRIGHT RED	1	-	-	-	EN,ET,ETX,HH,HXQ,LDB1,LDB3,LD4,LE,LEH4,LJT,LW2,LX26,PH,PM,PM2	
	19610-ZE0-000ZA	*R8*.....BRIGHT RED	1	(1)	-	-	QAA2,QA26,QBU2,QE,QEH,QH2,QJW1,QMH,QPU,QSJ,QTCC,QWA4,QXG2,QXQ	
			1	(1)	-	-	RH,SAD2,SDB1,SDB3,SJC,SKJ,SKR,SN,SW2,S1,TH,UH,U1,VAX4,VH,VMT	
			1	(1)	-	-	VS,VS1,V1,WDJ,WJ1,WM1,W1	
			1	(1)	-	-	DS,HHQ4,HTF2,HT2,HXU,HX2,HX26,HX4,H1,LAJ4,LD,LH,LHQ4,LJ,LJC	
			1	(1)	-	-	LJS,LSJ,LTJ,LTJ,LTK1,LTR,LXU,LX2,LX4,L1,QA,QA2,QD,QH,QHQ4,QH26,QLL	
			1	(1)	-	-	QM,QMA4,QMA8,QME4,QMX2,QT,QXC9,QXU,QX2,QX26,QX4,QX7,Q1,RD,RD4	
			1	(1)	-	-	RHC,RHQ4,RX4,R1,SAJ,SAJ4,SCJ,SD,SD16,SD4,SE,SH,SHQ4,SJ,SMA7	
			1	(1)	-	-	SMW2,STP,STS,SXS4,SX4,SX7,TX2,TX26,TX4,UXU,VED,VET,VEX,VEX7	
			1	(1)	-	-	VMS4,VPR4,VSX1,VXU,VX4,VX7,WDA6,WD12,WJ,WJP,WKD6,WKT2,WKT4	
			1	(1)	-	-	WKT6,WMA3,WME2,WME4	
			1	(1)	-	-	QXC,QXG,QXS,UX,VA	
			1	(1)	-	-	4142273 QXS2	
			1	(1)	-	-	2186370 4142673 HX,LX,PX,QX,RX,SMJ,SX,UX,VA,VED1,VSX,VX	
	19610-ZE0-000ZE	*NH1*.....BLACK	1	-	-	-	HXQ,HX2,LX2,PX2,QA2,QH2,QMX2,QWA4,QXC9,QXG2,QXQ,QXS2,QX2,SG24	
	19610-ZE0-000ZF	*NH246*.....LOOSEY GRAY	1	-	-	-	SM11,SM12,SM14,SSK1,SSK2,SSK3,SSX2,SSX4,TX2,TX4,VED1,VED6,VSX	
	19610-ZE0-000ZG	*T51*.....JACOBSEN ORANGE	1	-	-	-	QX, TX	
	19610-ZE0-000ZH	*NH31*.....MCKINLEY WHITE	1	-	-	-	VPR4	
	19610-ZE0-000ZK	*NH105*...MAT BLACK (#15-#20)	1	-	-	-	2242263 QJG2,QXG2	
			1	-	-	-	2243557 QXG	
			1	-	-	-	VEK	
			1	-	-	-	LJD2,QJG2,SJD2,SWX2,SWX4	

Ref. No.	Part No.	Description	Reqd. QTY				Serial No.	Parts catalogue code
			(1)	(2)	(3)	(4)		
(4)	19610-ZE0-000ZL	COVER COMP., FAN						
		*Y131*.....LIGHTNING YELLOW	1	-	-	-	VSX1	
	19610-ZE0-000ZM	*T76*.....IRIS GREEN	1	-	-	-	WJP1	
	19610-ZE0-000ZN	*T77*.....SEC WINE RED	1	-	-	-	VSX,VSX1	
	19610-ZE0-000ZP	*T73*.....EXEN GRAY	1	-	-	-	VEE1	
	19610-ZE0-000ZQ	*T79*.....BOMBARDIER YELLOW	1	-	-	-	QB26	
	19610-ZE0-000ZR	*T80*.....BAKELITE ORANGE	1	-	-	3892283	VSX,VSX1	
	19610-ZH7-V90ZA	*R8*.....BRIGHT RED	1	-	-	-	KRT,KRT4,KRT6,LTA	
	19610-ZK7-V00ZA	*R8*.....BRIGHT RED	1	-	-	-	AR,DKR,KR,KRA4,KRF4,KRS4	
	19610-ZK7-V00ZB	*T73*.....EXEN GRAY	1	-	-	-	KR	
	19610-ZK7-V00ZC	*NH1*.....BLACK	1	-	-	-	AR,KR	
	19610-ZB0-601ZD	*R280*.....POWER RED	1	-	-	4162942	LSJ4,SJC1,SJC5	
	19610-ZE0-000ZS	*R280*.....POWER RED	1	(1)	-	4142674	DS,HHQ4,HTF2,HT2,HX,HXU,HX2,HX26,HX4,H1,LAJ4,LD,LH,LHQ4,LJ,LJC LJS,LSJ,LTJ,LTJ,LTK1,LTR,LX,LXU,LX2,LX4,L1,PX,QA,QA2,QD,QH,QHQ4 QH26,QLL,QM,QMA4,QMA8,QME4,QMX2,QT,QX,QXC9,QXU,QX2,QX26,QX4 QX7,Q1,RD,RD4,RHC,RHQ4,RX,RX4,R1,SAJ,SAJ4,SCJ,SD,SD16,SD4,SE SH,SHQ4,SJ,SMA7,SMJ,SMW2,STP,STS,SX,SXS4,SX4,SX7,TX,TX2,TX26 TX4,UXU,VED,VED1,VET,VEX,VEX7,VMS4,VPR4,VSX,VSX1,VX,VXU,VX4 VX7,WDA6,WD12,WJ,WJP,WKD6,WKT2,WKT4,WKT6,WMA3,WME2,WME4	
			1	-	-	-	LTS	
			1	-	-	4142274	QXS2	
5	19610-ZE0-810ZA	COVER COMP., FAN (OIL ALERT)						
		*R8*.....BRIGHT RED	1	-	-	-	2186369 HX,LX,PX,QX,QXC,QXG,QXS,RX,SMJ,SX,TX,UX,VA,VED1,VSX,VX	
			-	(1)	-	-	2186369	
6	19612-ZH7-000	PLATE, SIDE (STD.)	1	-	-	-	DS,EN,ET,HH,HHQ4,HT2,LD,LDB1,LDB3,LD4,LE,LEH4,LH,LHQ4,LJ,LJD2 LJT,LSJ,LSJ4,LTJ,LTK1,LTR,LTS,PH,PM,PM2,QA,QA2,QA26,QD,QE QEH,QH,QHQ4,QH2,QH26,QM,QMA4,QME4,QPU,QSJ,QT,RD,RD4,RH,RHQ4 SAJ,SAJ4,SCJ,SD,SDB1,SDB3,SD16,SD4,SE,SH,SHQ4,SJ,SJC,SJD2,SKR SM11,SN,SSK1,SSK2,SSK3,STP,STS,SW2,TH,UH,VED,VEK,VET,VH,VS,VS1 WDA6,WDJ,WD12,WJ,WJP,WJP1,WJ1,WMA3,WME4,WM1	
			1	-	-	2564425	QXG2	
			-	(1)	1	1		
	19612-ZH7-810	PLATE, SIDE (OIL ALERT)	1	(1)	-	-	H1,L1,QXG2,R1,U1	
			1	(1)	-	-	3084882 ETX,HTF2,HX,HXQ,HX2,HX26,HX4,LTA,LX,LX2,LX26,LX4,PX,PX2,QBU2 QJW1,QLL,QMA8,QMH,QMX2,QTC2,QX,QXC,QXC9,QXG,QXQ,QX2,QX26,QX4 Q1,RX,RX4,SAD2,SG24,SJC1,SJC5,SMA7,SMJ,SMW2,SSX4,SX,SX4,S1,TX TX2,TX26,TX4,UX,VA,VAX4,VED1,VEE1,VEX,VPR4,VSX,VSX1,VX,VX4,V1 WKT2,WME2,W1	
	19612-ZH7-811		1	(1)	-	-	3084883 ETX,HXQ,QBU2,QXG,QXQ,SAD2,VA,V1	
			1	(1)	-	-	3084883 3182937 HTF2,HX,HX2,HX26,HX4,LTA,LX,LX2,LX26,LX4,PX,PX2,QJW1,QLL,QMA8 QMH,QMX2,QTC2,QX,QXC,QXC9,QX2,QX26,QX4,Q1,RX,RX4,SG24,SJC1 SJC5,SMA7,SMJ,SMW2,SSX4,SX,SX4,S1,TX,TX2,TX26,TX4,UX,VAX4,VED1 VEE1,VEX,VPR4,VSX,VSX1,VX,VX4,WKT2,WME2,W1	
			1	-	-	-	3182937 VMS4	
	19612-ZH7-812	PLATE, SIDE	1	(1)	-	-	3182938 3257376 HTF2,HX,HX2,HX26,HX4,LTA,LX,LX2,LX26,LX4,PX,PX2,QJW1,QLL,QMA8 QMH,QMX2,QTC2,QX,QXC,QXC9,QX2,QX26,QX4,Q1,RX,RX4,SG24,SJC1 SJC5,SMA7,SMJ,SMW2,SSX4,SX,SX4,S1,TX,TX2,TX26,TX4,UX,VAX4,VED1 VEE1,VEX,VMS4,VPR4,VSX,VSX1,VX,VX4,WKT2,WME2,W1	
			1	-	-	-	LJC,QX7,SX7,VEX7,VX7,WKT4	
	19612-ZK7-V00		1	-	-	-	AR,DKR,KR,KRA4,KRF4,KRS4,KRT,KRT4,KRT6	
	19611-ZH7-810	PLATE COMP., SIDE (OIL ALERT)	1	(1)	-	-	3257377 HTF2,HX,HX2,HX26,HX4,LTA,LX,LX2,LX26,LX4,PX,PX2,QJW1,QLL,QMA8 QMH,QMX2,QTC2,QX,QXC,QXC9,QX2,QX26,QX4,Q1,RX,RX4,SG24,SJC1 SJC5,SMA7,SMJ,SMW2,SSX4,SX,SX4,S1,TX,TX2,TX26,TX4,UX,VAX4,VED1 VEE1,VEX,VMS4,VPR4,VSX,VSX1,VX,VX4,WKT2,WME2,W1	
			1	-	-	-	HXU,LJC,LXU,QWA4,QXU,QX7,SM12,SM14,SSX2,SWX2,SWX4,SXS4,SX7,UXU VED6,VEX7,VMT,VXU,VX7,WKD6,WKT6	



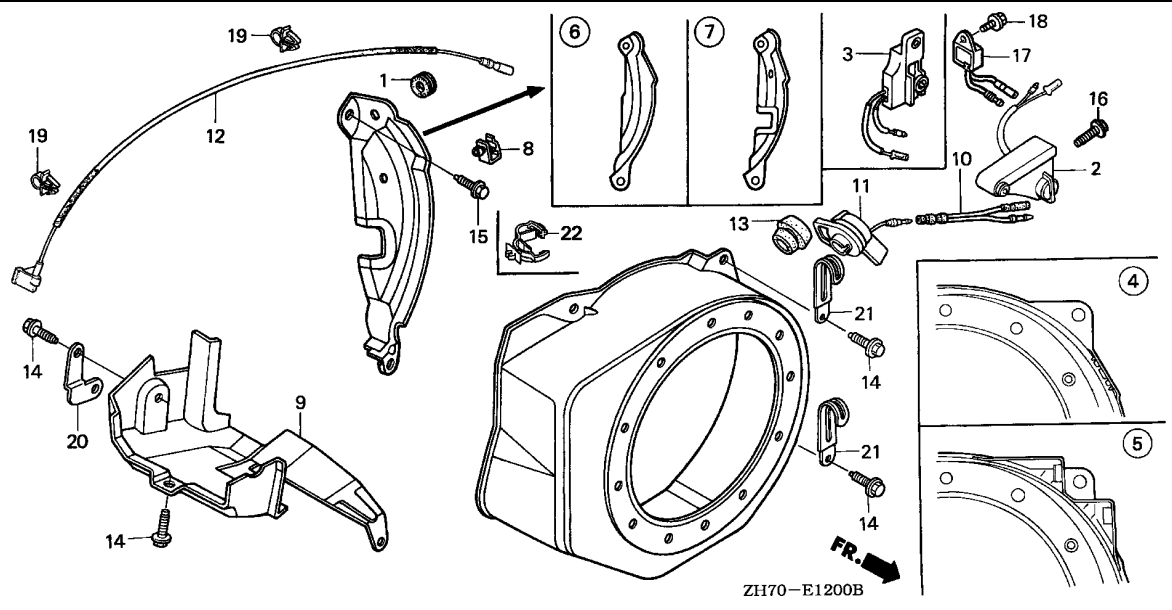

Ref. No.	Part No.	Description	Reqd. QTY				Serial No.	Parts catalogue code
			(1)	(2)	(3)	(4)		
7	19612-ZH7-820	PLATE, SIDE (LAMP)	1	(1)	-	-	-----	H1,LW2,U1,V1
			1	(1)	-	-	-----	3182937 L1,QB26,QJG2,Q1,RHC,R1,SKJ,S1,W1
			1	-	-	-	-----	3084883 QXS
			1	-	-	-	-----	3084883 3182937 QXS2
			1	-	-	-	-----	3182938 L1,QB26,QJG2,Q1,RHC,SKJ,S1,W1
19612-ZH7-821	PLATE, SIDE	1	(1)	-	-	-----	3182938 3257376 QXS2,R1	
		1	-	-	-	-----	LAJ4,LJS	
19612-ZH7-830	PLATE, SIDE (ALERT & LAMP)	1	-	-	-	-----	3084882 QXS,QXS2	
19611-ZH7-820	PLATE COMP., SIDE (ALERT & LAMP)	-	(1)	-	-	-	-	
8	19613-ZE1-000	CLAMPER, CORD	1	(1)	-	-	-----	3257377 QXS2,R1
			1	(1)	-	-	-----	ETX,H1,L1,U1
			1	(1)	-	-	-----	2867760 HTF2,HX,HXQ,HX2,HX26,HX4,LTA,LX,LX2,LX26,LX4,PX,PX2,QBU2,QLL,QMA8,QMX2,QTC2,QX,QXC,QXC9,QXG,QXQ,QXS,QXS2,QX2,QX26,QX4,Q1,RX,RX4,R1,SAD2,SG24,SJC1,SMA7,SMJ,SMW2,SSX4,SX, SX4,S1,TX,TX2,TX26,TX4,UX,VA,VAX4,VED1,VEX,VSX,VSX1,VX,VX4,V1,WKT2,WME2,W1
			1	-	-	-	-----	2569451 QXG2
			1	-	-	-	-----	3242876 VPR4
19613-ZE1-010	CLAMP, CORD	1	-	-	-	-----	3242877 3257376 VPR4	
19613-ZE1-020	.....	1	-	-	-	-----	3257377 VPR4	

Ref. No.	Part No.	Description	Reqd. QTY				Serial No.	Parts catalogue code
			(1)	GX120K1 (2)	(3)	(4)		
9	19630-ZH7-000	SHROUD COMP. ....	1	-	-	-	-----	DS,EN,ET,ETX,HH,HHQ4,HTF2,HT2,HX,HXQ,HXU,HX2,HX26,HX4,LAJ4,LD,LDB1,LDB3,LD4,LE,LEH4,LH,LHQ4,LJ,LJC,LJD2,LJS,LJT,LSJ,LSJ4,LTJ,LTJ1,LTR,LTS,LW2,LX,LXU,LX2,LX26,LX4,PH,PM,PM2,PX,FX2,QA,QA2,QA26,QBU2,QB26,QD,QE,QEH,QH,QHQ4,QH2,QH26,QJG2,QJW1,QLL,QM,QMA4,QMA8,QME4,QMH,QMX2,QPU,QSJ,QT,QTC2,QWA4,QX,QXC,QXC9,QXG,QXG2,QXQ,QXS,QXS2,QXU,QX2,QX26,QX4,QX7,RD,RD4,RH,RHC,RHQ4,RX,RX4,SAD2,SAJ,SAJ4,SCJ,SD,SDB1,SDB3,SD16,SD4,SE,SG24,SH,SHQ4,SJ,SJC,SJC1,SJC5,SJD2,SKJ,SKR,SMA7,SMJ,SMW2,SM11,SM12,SM14,SN,SSK1,SSK2,SSK3,SSX2,SSX4,STP,STS,SWX2,SWX4,SW2,SX,SXS4,SX4,SX7,TH,TX,TX2,TX26,TX4,UH,UX,UXU,VA,VAX4,VED,VED1,VED6,VEE1,VEK,VET,VEX,VEX7,VH,VMS4,VMT,VPR4,VS,VSX,VSX1,VS1,VX,VXU,VX4,VX7,WDA6,WDJ,WD12,WJ,WJP,WJP1,WJ1,WKD6,WKT2,WKT4,WKT6,WMA3,WME2,WME4,WM1
10	32197-ZH8-003	SUB HARNESS .....	1	-	-	-	-----	HTF2,HXQ,HXU,HX2,HX26,HX4,LTA,LXU,LX2,LX26,LX4,FX2,QBU2,QLL,QMA8,QMX2,QXC9,QXQ,QXS2,QXU,QX2,QX26,QX4,RX4,SAD2,SJC1,SMA7,SMW2,SSX4,SX4,TX2,TX26,TX4,UXU,VAX4,VEX,VPR4,VSX1,VXU,VX4,WKT2
			1	-	-	2186370	-----	ETX,LX,PX,RX,SMJ,SX,UX,VA,VED1,VSX,VX
			1	-	-	2564424	-----	QXG2
			1	-	-	2867760	-----	QTC2,SG24,WME2
			1	-	-	2186370	-----	2867760 HX,QX,QXC,QXG,QXS,TX
			-	1	-	-	-----	2186370
11	36100-ZE1-015	SWITCH ASSY., ENGINE STOP ...	1	-	-	-	-----	AR,DS,EN,HH,HT2,KR,KRT,KRT6,LD,LDB1,LDB3,LE,LH,LJ,LJS,LJT,LSJ,LTJ,LTJ1,LTR,LTS,LW2,PH,PM,PM2,QA,QA2,QA26,QH,QH26,QJG2,QM,QSJ,QT,QXG2,RD,RH,SAJ,SD,SDB1,SDB3,SD16,SH,SJ,SJC,SKJ,SM11,SN,SSK1,SSK2,SSK3,STP,STS,SW2,TH,UH,VED,VET,VH,VS,VS1,WDA6,WDJ,WD12,WJ,WJP,WJP1,WJ1,WM1
			1	-	-	2321890	-----	QE
			1	-	-	2476407	-----	QE,QLL,RHC,SE,VEX
			1	-	-	2867760	-----	HTF2,HXQ,HX2,HX26,LTA,LX2,LX26,PX2,QBU2,QMX2,QTC2,QXC9,QXQ,QXS2,QX2,QX26,SAD2,SJC1,SMW2,TX2,TX26,VSX1,WKT2,WME2
			1	-	-	2923168	-----	DKR
			1	-	-	2186370	-----	2867760 HX,LX,PX,QX,QXC,QXG,QXS,RX,SMJ,SX,TX,UX,VA,VED1,VSX,VX
			-	(1)	1	1	-----	
36100-ZH7-003	.....		1	-	-	-	-----	HXU,LJC,LXU,QJW1,QMH,QXU,SJC5,SM12,SSX2,SWX2,UXU,VED6,VEE1,VMT,VXU,WKD6,WKT6
			1	-	-	2867761	-----	HTF2,HX,HXQ,HX2,HX26,LTA,LX,LX2,LX26,PX,FX2,QBU2,QMX2,QTC2,QX,QXC,QXC9,QXG,QXQ,QXS,QXS2,QX2,QX26,RX,SAD2,SJC1,SMJ,SMW2,SX,TX,TX2,TX26,UX,VA,VED1,VSX,VSX1,VX,WKT2,WME2
36100-ZH8-W41	.....		1	-	-	-	-----	HHQ4,KRA4,KRF4,KRT4,LD4,LHQ4,LSJ4,QHQ4,QMA4,QME4,RD4,RHQ4,SAJ4,SD4,SHQ4,WMA3,WME4
			1	-	-	2476408	-----	QE,RHC,SE
			1	-	-	2923169	-----	DKR
			1	-	-	2867760	-----	HX4,LX4,QMA8,QX4,RX4,SG24,SMA7,SSX4,SX4,TX4,VAX4,VX4
			1	-	-	2476408	-----	2867760 QLL,VEX
36100-ZH7-W41	.....		1	-	-	-	-----	QWA4,QX7,SM14,SWX4,SXS4,SX7,VEX7,VMS4,VX7,WKT4
			1	-	-	2867761	-----	HX4,LX4,QLL,QMA8,QX4,RX4,SG24,SMA7,SSX4,SX4,TX4,VAX4,VEX,VX4
35120-Z0D-V81	.....		1	-	-	-	-----	KRS4



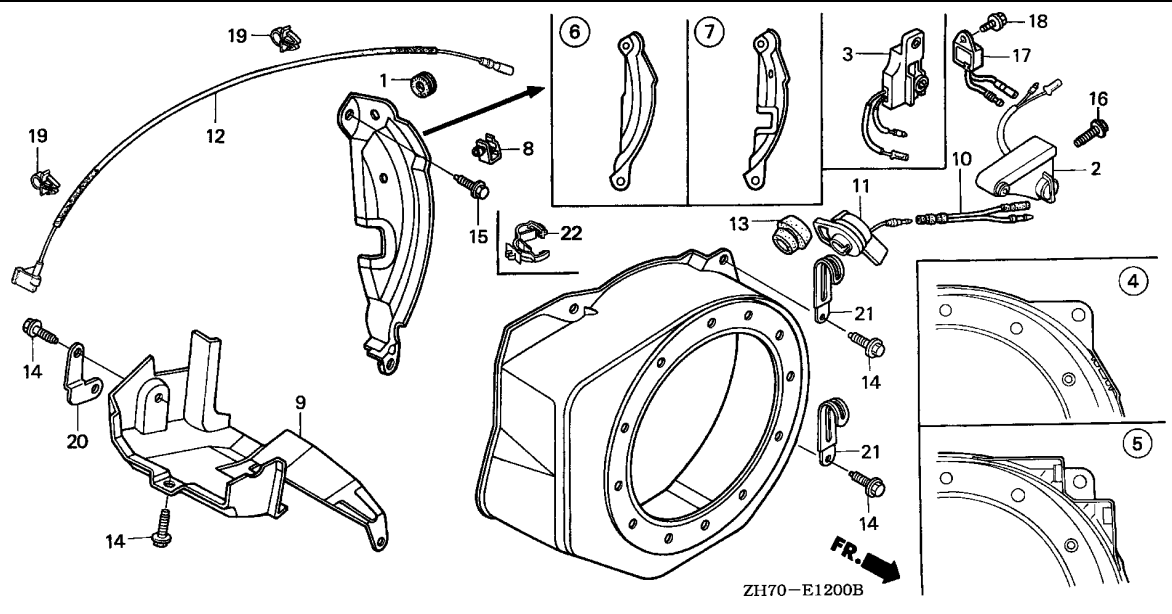

ZH70-E1200B

Ref. No.	Part No.	Description	Reqd. QTY				Serial No.	Parts catalogue code
			(1)	(2)	(3)	(4)		
			GX120K1					
12	36101-ZE1-010	CORD, STOP SWITCH (370MM) ...	1	-	-	-	-----	AR,DKR,DS,EN,ET,ETX,HH,HHQ4,HTF2,HT2,HX,HXQ,HXU,HX2,HX26,HX4 KR,KRA4,KRF4,KRS4,KRT,KRT4,KRT6,LAJ4,LD,LDB1,LDB3,LD4,LE,LEH4 LH,LHQ4,LJ,LJC,LJD2,LJS,LJT,LSJ,LSJ4,LTA,LTJ,LTK1,LTR,LTS,LW2 LX,LXU,LX2,LX26,LX4,PH,PM,PM2,PX,PX2,QA,QAA2,QA2,QA26,QBU2,QD QE,QEH,QH,QHQ4,QH2,QH26,QJG2,QJW1,QLL,QM,QMA4,QMA8,QME4,QMH QMX2,QPU,QSJ,QT,QTC2,QWA4,QX,QXC,QXC9,QXG,QXG2,QXQ,QXS,QXS2 QXU,QX2,QX26,QX4,QX7,RD,RD4,RH,RHC,RHQ4,RX,RX4,SAD2,SAJ,SAJ4 SCJ,SD,SDB1,SDB3,SD16,SD4,SE,SG24,SH,SHQ4,SJ,SJC,SJC1,SJC5 SJD2,SKJ,SKR,SMA7,SMJ,SMW2,SM11,SM12,SM14,SN,SSK1,SSK2,SSK3 SSX2,SSX4,STP,STS,SWX2,SWX4,SW2,SX,SXS4,SX4,SX7,TH,TX,TX2,TX26 TX4,UH,UX,UXU,VA,VAX4,VED,VED1,VED6,VEE1,VEK,VET,VEX,VEX7,VH VMS4,VMT,VPR4,VS,VSX,VSX1,VS1,VX,VXU,VX4,VX7,WDA6,WDJ,WD12,WJ WJP,WJP1,WJ1,WKD6,WKT2,WKT4,WKT6,WMA3,WME2,WME4,WM1
	36101-ZK7-U50	CORD, STOP SWITCH (BOMBARDIER)	1	-	-	-	-----	QB26
13	81329-567-020	GROMMET, DRAIN HOLE .....	1	-	-	-	-----	ET,ETX,LAJ4,LEH4,LJD2,QB26,QPU,SCJ,SJD2,SKR,VEK,VPR4
			1	-	-	-	2321891	QEH

Ref. No.	Part No.	Description	Reqd. QTY				Serial No.	Parts catalogue code
			(1)	GX120K1 (2)	(3)	(4)		
14	90013-883-000	BOLT, FLANGE, 6X12(CT200) ...	4 6	- -	- -	- -	AR,DKR,KRF4,KRS4 DS,EN,ET,ETX,HH,HHQ4,HTF2,HT2,HX,HXQ,HXU,HX2,HX26,HX4,KRA4 KRT4,LAJ4,LD,LDB1,LDB3,LD4,LE,LEH4,LH,LHQ4,LJ,LJC,LJD2,LJS,LJT LSJ,LSJ4,LTA,LTJ,LTK1,LTR,LTS,LW2,LX,LXU,LX2,LX26,LX4,PH,PM PM2,PX,PX2,QA,QAA2,QA2,QA26,QBU2,QB26,QD,QE,QEH,QH,QHQ4,QH2 QH26,QJG2,QJW1,QLL,QM,QMA4,QMA8,QME4,QMH,QMX2,QPU,QSJ,QT,QTC2 QWA4,QX,QXC,QXC9,QXG,QXG2,QXQ,QXS,QXS2,QXU,QX2,QX26,QX4,QX7,RD RD4,RH,RHC,RHQ4,RX,RX4,SAD2,SAJ,SAJ4,SCJ,SD,SDB1,SDB3,SD16,SD4 SE,SG24,SH,SHQ4,SJ,SJC,SJC1,SJC5,SJD2,SKJ,SKR,SMA7,SMJ,SMW2 SM11,SM12,SM14,SN,SSK1,SSK2,SSK3,SSX2,SSX4,STP,STS,SWX2,SWX4 SW2,SX,SXS4,SX4,SX7,TH,TX,TX2,TX26,TX4,UH,UX,UXU,VA,VAX4,VED VED1,VED6,VEE1,VEK,VET,VEX,VEX7,VH,VMS4,VMT,VPR4,VS,VSX,VSX1 VS1,VX,VXU,VX4,VX7,WDA6,WDJ,WD12,WJ,WJP,WJP1,WJ1,WKD6,WKT2 WKT4,WKT6,WMA3,WME2,WME4,WM1	
15	90022-888-010	BOLT, FLANGE, 6X20(CT200) ...	- 1	6 1	6 1	6 1		
16	95701-06008-00	BOLT, FLANGE, 6X8 .....	2 -	- (2)	- -	- -	2186369 HX,LX,PX,QX,QXC,QXG,QXS,RX,SMJ,SX,TX,UX,VA,VED1,VSX,VX 2186369	
17	34150-ZH7-003	ALERT UNIT, OIL .....	1	(1)	-	-	3257377 HX,HX26,HX4,LTA,LX,LX26,LX4,PX,QJW1,QLL,QMA8,QMH,QTC2,QX,QXC QX26,QX4,Q1,RX,RX4,R1,SG24,SJC1,SJC5,SMA7,SMJ,SSX4,SX,SX4,S1 TX,TX26,TX4,UX,VAX4,VED1,VEE1,VEX,VMS4,VPR4,VSX,VSX1,VX,VX4 WME2,W1 1 - - - HXU,LJC,LXU,QWA4,QXU,QX7,SM12,SM14,SSX2,SWX2,SWX4,SXS4,SX7,UXU VED6,VEX7,VMT,VXU,VX7,WKD6,WKT4,WKT6	
18	95701-06008-00	BOLT, FLANGE, 6X8 .....	1 1	- (1)	- -	- -	3259269 HX,HX26,HX4,LTA,LX,LX26,LX4,PX,QJW1,QLL,QMA8,QMH,QTC2,QX,QXC QX26,QX4,Q1,RX,RX4,R1,SG24,SJC1,SJC5,SMA7,SMJ,SSX4,SX,SX4,S1 TX,TX26,TX4,UX,VAX4,VED1,VEE1,VEX,VMS4,VPR4,VSX,VSX1,VX,VX4 WME2,W1 1 - - - HXU,LJC,LXU,QWA4,QXU,QX7,SM12,SM14,SSX2,SWX2,SWX4,SXS4,SX7,UXU VED6,VEX7,VMT,VXU,VX7,WKD6,WKT4,WKT6	
19	36103-ZE1-000	HOLDER, STOP SWITCH CORD .....	2	2	-	-	3259269 HTF2,HX2,LX2,PX2,QMX2,QXC9,QXS2,QX2,SMW2,TX2,WKT2 DS,HX,H1,LD,LJ,LTA,LTJ,LX,PH,PX,QD,QSJ,QX,Q1,RD,RX,R1,SD,SJ SKJ,SMJ,STS,SX,TH,UH,UX,U1,VET,VH,VX,V1,WJ,W1	
20	32303-ZE0-850	STAY, CORD CLIP .....	1	-	-	-	VEK	
21	91406-657-671	CLIP, WIRE HARNESS .....	2	-	-	-	SJD2	
22	90601-ZH7-003	CLIP, HARNESS .....	1	-	-	-	2867760 QMH	
	90601-ZH7-013	.....	1	(1)	-	-	2867761 HTF2,HX,HXQ,HX2,HX26,HX4,LTA,LX,LX2,LX26,LX4,PX,PX2,QBU2,QLL QMA8,QMH,QMX2,QTC2,QX,QXC,QXC9,QXG,QXQ,QXS,QXS2,QX2,QX26,QX4 Q1,RX,RX4,R1,SAD2,SG24,SJC1,SMA7,SMJ,SMW2,SSX4,SX,SX4,S1,TX TX2,TX26,TX4,UX,VA,VAX4,VED1,VEX,VSX,VSX1,VX,VX4,V1,WKT2,WME2 W1 1 - - - HXU,LJC,LXU,QJW1,QWA4,QXU,QX7,SJC5,SM12,SM14,SSX2,SWX2,SWX4 SXS4,SX7,UXU,VED6,VEE1,VEX7,VMS4,VMT,VXU,VX7,WKD6,WKT4,WKT6	



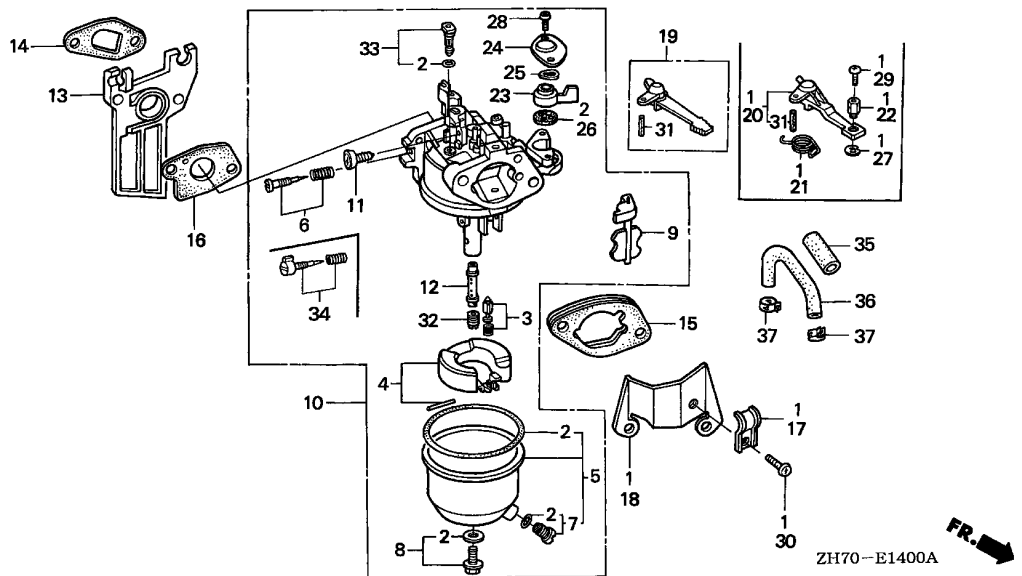

Ref. No.	L.O.N.	(Relative ref. Number) Description	F.R.T.
1	8101C4	CHOKE KIT, REMOTE CONTROL	0.2
2	3111B1	GASKET SET, CARBURETOR	0.3
3	3111E1	VALVE SET, FLOAT AND/OR FLOAT SET	0.3
6	3111D7	SCREW SET, PILOT	0.2
10	3111F3	CARBURETOR	0.2
13	3111C0	INSULATOR, CARBURETOR AND/OR PACKING, INSULATOR	0.2
16	3111C8	PACKING, CARBURETOR	0.2
19	8101F9	LEVER, CARBURETOR CHOKE	0.2
26	3101C5	PACKING, FUEL COCK	0.2
32	3111C3	JET, MAIN	0.3
36	3101F6	TUBE, FUEL	0.2

2

Ref. No.	Part No.	Description	Reqd. QTY				Serial No.	Parts catalogue code
			(1)	(2)	(3)	(4)		
1	06164-ZE0-000	CHOKE KIT, REMOTE CONTROL	-	(1)	-	-	U1	
	06164-ZE1-000	.....	-	(1)	-	-	2377547	H1,L1,Q1,R1,S1,V1,W1
2	16010-ZB1-015	GASKET SET	1	-	-	-	2377548	AR,DKR,KR,KRA4,KRF4,KRS4,KRT,KRT4,KRT6
	16010-ZE0-025	.....	1	-	-	-		LD,LDB1,LDB3,LD4,LE,LSJ4,LW2,PM,PM2,QD,QE,QM,RD,RD4,SD,SDB1,SDB3,SD16,SD4,SE,SW2,WMA3,WME4,WM1
3	16011-ZE0-005	VALVE SET, FLOAT	1	-	-	-		AR,DKR,KR,KRA4,KRF4,KRS4,KRT,KRT4,KRT6,LD,LDB1,LDB3,LD4,LE,LSJ4,LW2,PM,PM2,QD,QE,QM,RD,RD4,SD,SDB1,SDB3,SD16,SD4,SE,SW2,WMA3,WME4,WM1
4	16013-ZE0-005	FLOAT SET	1	-	-	-		AR,DKR,KR,KRA4,KRF4,KRS4,KRT,KRT4,KRT6,LD,LDB1,LDB3,LD4,LE,LSJ4,LW2,PM,PM2,QD,QE,QM,RD,RD4,SD,SDB1,SDB3,SD16,SD4,SE,SW2,WMA3,WME4,WM1
5	16015-ZE1-811	CHAMBER SET, FLOAT (CARBURETOR NO.)	1	(1)	-	-		AR,DKR,KR,KRA4,KRF4,KRS4,KRT,KRT4,KRT6,U1
	16015-ZE0-831	..... (CARBURETOR NO.)	1	(1)	-	-	BE12B B	H1,LD,LDB1,LDB3,LD4,LE,LW2,L1,PM,PM2,QD,QE,QM,Q1,RD,RD4,R1,SD,SDB1,SDB3,SD16,SD4,SE,SW2,S1,V1,WMA3,W1
		..... (CARBURETOR NO.)	1	(1)	-	-	BE12B C	H1,LD,LDB1,LDB3,LD4,LE,LW2,L1,PM,PM2,QD,QE,QM,Q1,RD,RD4,R1,SD,SDB1,SDB3,SD16,SD4,SE,SW2,S1,V1,WMA3,W1
6	16016-ZE0-005	SCREW SET, PILOT (CARBURETOR NO.)	1	-	-	-		KRA4,KRT6,LDB1,LD4,LE,LW2,PM,PM2,QM,SW2
	///	.....	1	-	-	-	BE12B C	LD,LDB3,LSJ4,QD,QE,RD,RD4,SD,SDB1,SDB3,SD16,SD4,SE,WMA3,WME4
	///	.....	1	-	-	-	BE61F A	WM1
	///	.....	1	-	-	-	BE62A A	AR,DKR,KR,KRT,KRT4
		.....	-	(1)	-	-		

Ref. No.	Part No.	Description	Reqd. QTY				Serial No.	Parts catalogue code
			(1)	GX120K1 (2)	(3)	(4)		
7	16024-ZE1-811	SCREW SET, DRAIN .....	1	-	-	-	AR,DKR,KR,KRA4,KRF4,KRS4,KRT,KRT4,KRT6,LD,LDB1,LDB3,LD4,LE LSJ4,LW2,PM,PM2,QD,QE,QM,RD,RD4,SD,SDB1,SDB3,SD16,SD4,SE,SW2 WMA3,WME4,WM1	
8	16028-ZE0-005	SCREW SET .....	1	(1)	-	-	AR,DKR,KR,KRA4,KRF4,KRS4,KRT,KRT4,KRT6,LD,LDB1,LDB3,LD4,LE LSJ4,LW2,PM,PM2,QD,QE,QM,RD,RD4,SD,SDB1,SDB3,SD16,SD4,SE,SW2 WMA3,WME4,WM1	
9	16044-ZE0-005	CHOKE SET .....	1	-	-	-	AR,DKR,KR,KRA4,KRF4,KRS4,KRT,KRT4,KRT6,LDB1,LDB3,LD4,LSJ4,RD4 SDB1,SDB3,SD16,SD4,WMA3,WME4,WM1	
		(CARBURETOR NO.)	1	-	-	BE12B B	LD,LE,LW2,PM,PM2,QD,QE,QM,RD,SD,SE,SW2	
10	16100-ZH7-810	CARBURETOR ASSY. (BE12B A) ..	1	(1)	-	BE12B B	2354502 LD,LE,LW2,PM,PM2,QD,QE,QM,RD,SD,SE,SW2 2354502	
	16100-ZH7-811	CARBURETOR ASSY. (BE12B B) ..	1	(1)	-	2354503	2724424 H1,LD,LE,LW2,L1,PM,PM2,QD,QE,QM,Q1,RD,R1,SD,SE,SW2,S1,V1,W1 2724424 LDB1,LDB3,LD4,RD4,SDB1,SDB3,SD16,SD4,WMA3	
	16100-ZH7-812	CARBURETOR ASSY. (BE12B C) ..	1	(1)	-	2354503	U1	
			1	(1)	-	2724425	H1,LDB1,LD4,LE,LW2,L1,PM,PM2,QM,Q1,R1,SW2,S1,V1,W1	
			1	-	-	3491424	LSJ4,WME4	
			1	-	-	2724425	2988646 SD16	
			1	-	-	2724425	3491424 LD,LDB3,QD,QE,RD,RD4,SD,SDB1,SDB3,SD4,SE,WMA3	
	16100-ZK7-801	CARBURETOR ASSY. (BE61F A) ..	1	-	-	3491424	WM1	
	16100-ZH7-W71	CARBURETOR ASSY. (BE61D B) ..	1	-	-	2988647	SD16	
			1	-	-	3491425	LD,LDB3,LSJ4,QD,RD,RD4,SD,SDB1,SDB3,SD4,WMA3,WME4,WM1	
	16100-ZH7-W81	CARBURETOR ASSY. (BE61G A) ..	1	-	-	3491425	QE,SE	
	16100-ZK7-V00	CARBURETOR ASSY. (BE62A A) ..	1	-	-	3220948	AR	
	16100-ZK7-V01	.....	1	-	-	.....	KRA4,KRT6	
			1	-	-	6276049	DKR,KR,KRT,KRT4	
	16100-ZK7-U31	CARBURETOR ASSY. (BE62C A) ..	1	-	-	.....	KRF4,KRS4	
			1	-	-	3220949	AR	
			1	-	-	6276050	DKR,KR,KRT,KRT4	
11	16124-ZE0-005	SCREW, THROTTLE STOP .....	1	-	-	-	AR,DKR,KR,KRA4,KRF4,KRS4,KRT,KRT4,KRT6,LD,LDB1,LDB3,LD4,LE LSJ4,LW2,PM,PM2,QD,QE,QM,RD,RD4,SD,SDB1,SDB3,SD16,SD4,SE,SW2 WMA3,WME4,WM1	
12	16166-ZH7-A50	NOZZLE, MAIN .....	1	(1)	-	-	AR,DKR,KR,KRA4,KRF4,KRS4,KRT,KRT4,KRT6	
	16166-ZH7-820	.....	1	-	-	-	AR,DKR,KR,KRA4,KRF4,KRS4,KRT,KRT4,KRT6	
		(CARBURETOR NO.)	1	-	-	BE12B A	LD,LE,LW2,PM,PM2,QD,QE,QM,RD,SD,SE,SW2	
			1	(1)	-	BE12B A	.....	
	16166-ZH7-W50	.....	1	-	-	.....	LDB1,LDB3,LD4,LSJ4,RD4,SDB1,SDB3,SD16,SD4,WMA3,WME4,WM1	
		(CARBURETOR NO.)	1	-	-	BE12B B	LD,LE,LW2,PM,PM2,QD,QE,QM,RD,SD,SE,SW2	
			1	(1)	-	BE12B B	.....	
13	16211-ZE0-000	INSULATOR, CARBURETOR .....	1	-	-	-	AR,DKR,KR,KRA4,KRF4,KRS4,KRT,KRT4,KRT6,LD,LDB1,LDB3,LD4,LE LSJ4,LW2,PM,PM2,QD,QE,QM,RD,RD4,SD,SDB1,SDB3,SD16,SD4,SE,SW2 WMA3,WME4,WM1	
14	16212-ZH7-000	PACKING, INSULATOR .....	1	-	-	-	2272434 LW2,PM,PM2,QM,SW2	
			1	(1)	-	-	2272434	
	16212-ZH7-800	.....	1	-	-	-	AR,DKR,KR,KRA4,KRF4,KRS4,KRT,KRT4,KRT6,LD,LDB1,LDB3,LD4,LE LSJ4,QD,QE,RD,RD4,SD,SDB1,SDB3,SD16,SD4,SE,WMA3,WME4,WM1	
			1	-	-	2272435	LW2,PM,PM2,QM,SW2	
			1	(1)	-	2272435	.....	
15	16220-ZE1-020	SPACER COMP., CARBURETOR .....	1	-	-	-	AR,DKR,KR,KRA4,KRF4,KRS4,KRT,KRT4,KRT6,LD,LDB1,LDB3,LD4,LE LSJ4,LW2,PM,PM2,QD,QE,QM,RD,RD4,SD,SDB1,SDB3,SD16,SD4,SE,SW2 WMA3,WME4,WM1	
			1	-	-	-	.....	





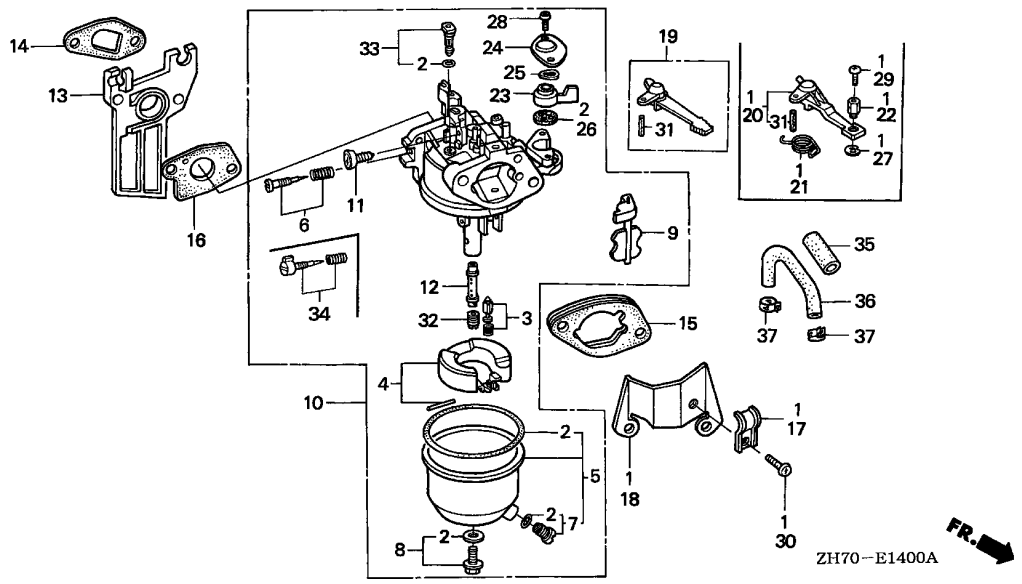

Ref. No.	Part No.	Description	Reqd. QTY				Serial No.	Parts catalogue code
			(1)	(2)	(3)	(4)		
16	16221-ZE1-000	PACKING, CARBURETOR	1	-	-	-	2272434 LW2,PM,PM2,QM,SW2	
	16221-ZH8-800		1	-	-	-	2272434	
			1	-	-	-	2533057 LD,LE,QD,QE,RD,SD,SE	
			1	-	-	-	2541043 LD4,RD4,SD4	
			1	-	-	-	2272435 LW2,PM,PM2,QM,SW2	
	16221-ZH8-801		1	(1)	-	-	AR,DKR,H1,KR,KRA4,KRF4,KRS4,KRT,KRT4,KRT6,LDB1,LDB3,LSJ4,Q1,R1	
			1	-	-	-	SDB1,SDB3,SD16,V1,WMA3,WME4,WM1	
			1	-	-	-	2533058 LD,LE,LW2,PM,PM2,QD,QE,QM,RD,SD,SE,SW2	
			1	-	-	-	2541044 LD4,RD4,SD4	
17	16582-883-300	HOLDER, CONTROL CABLE	-	(1)	-	-		
18	16598-ZE0-000	STAY, CHOKE CONTROL	-	(1)	-	-	U1	
	16598-ZE1-000		-	(1)	-	-	2377547 H1,L1,Q1,R1,S1,V1,W1	
			-	(1)	-	-	2377548 H1,L1,Q1,R1,S1,V1,W1	
19	16610-ZE1-000	LEVER COMP., CHOKE (STD.)	1	-	-	-	AR,DKR,KR,KRA4,KRF4,KRS4,KRT,KRT4,KRT6,LD,LDB1,LDB3,LD4,LE	
							LSJ4,LW2,PM,PM2,QD,QE,QM,RD,RD4,SD,SDB1,SDB3,SD16,SD4,SE,SW2	
							WMA3,WME4,WM1	
20	16610-ZE1-810	LEVER COMP., CHOKE (REMOTE)	-	(1)	-	-		
21	16615-ZE1-010	SPRING, RETURN	-	(1)	-	-		
22	16617-890-010	HOLDER, CABLE	-	(1)	-	-		
23	16953-ZE1-812	LEVER, COCK	1	-	-	-	LD,LDB1,LDB3,LD4,LE,LSJ4,LW2,PM,PM2,QD,QE,QM,RD,RD4,SD,SDB1	
							SDB3,SD16,SD4,SE,SW2,WMA3,WME4,WM1	
24	16954-ZE1-811	PLATE, LEVER SETTING	-	(1)	-	-	U1	
	16954-ZE1-812		1	(1)	-	-	H1,LD,LDB1,LDB3,LD4,LE,LSJ4,LW2,L1,PM,PM2,QD,QE,QM,Q1,RD,RD4	
							R1,SD,SDB1,SDB3,SD16,SD4,SE,SW2,S1,V1,WMA3,WME4,WM1,W1	

Ref. No.	Part No.	Description	Reqd. QTY				Serial No.	Parts catalogue code
			(1)	GX120K1 (2)	(3)	(4)		
25	16956-ZE1-811	SPRING, COCK LEVER .....	1	-	-	-	LD,LDB1,LDB3,LD4,LE,LSJ4,LW2,PM,PM2,QD,QE,QM,RD,RD4,SD,SDB1 SDB3,SD16,SD4,SE,SW2,WMA3,WME4,WM1	
			-	(1)	-	-		
26	16957-ZE1-812	PACKING, FUEL COCK .....	1	-	-	-	LD,LDB1,LDB3,LD4,LE,LSJ4,LW2,PM,PM2,QD,QE,QM,RD,RD4,SD,SDB1 SDB3,SD16,SD4,SE,SW2,WMA3,WME4,WM1	
			-	(1)	-	-		
27	90605-230-000	CIRCLIP, 5MM .....	-	(1)	-	-		
28	93500-03008-1G	SCREW, PAN, 3X8 .....	2	(2)	-	-	BE12B B H1,LD,LDB1,LDB3,LD4,LE,LW2,L1,PM,PM2,QD,QE,QM,Q1,RD,RD4,R1,SD SDB1,SDB3,SD16,SD4,SE,SW2,S1,V1,WMA3,W1	
		(CARBURETOR NO.)	-	(2)	-	-	U1	
	93500-03006-1H	SCREW, PAN, 3X6 .....	2	(2)	-	-	BE12B C H1,LD,LDB1,LDB3,LD4,LE,LW2,L1,PM,PM2,QD,QE,QM,Q1,RD,RD4,R1,SD SDB1,SDB3,SD16,SD4,SE,SW2,S1,V1,WMA3,W1	
		(CARBURETOR NO.)	2	-	-	-	LSJ4,WME4,WM1	
29	93500-04008-0A	SCREW, PAN, 4X8 .....	-	(1)	-	-		
30	93500-05008-0A	SCREW, PAN, 5X8 .....	-	(1)	-	-		
31	94305-20122	PIN, SPRING, 2X12 .....	1	-	-	-	AR,DKR,KR,KRA4,KRF4,KRS4,KRT,KRT4,KRT6,LD,LDB1,LDB3,LD4,LE LSJ4,LW2,PM,PM2,QD,QE,QM,RD,RD4,SD,SDB1,SDB3,SD16,SD4,SE,SW2 WMA3,WME4,WM1	
			-	(1)	-	-		
32	99101-ZF5-0550	JET, MAIN, #55 .....	(1)	(1)	-	-	LDB1,LD4,LE,LW2,PM2,SW2,U1,V1	
		(CARBURETOR NO.)	(1)	-	-	-	BE61D A SD16	
	99101-ZF5-0580	JET, MAIN, #58 .....	(1)	(1)	-	-	LDB1,LD4,LE,LW2,PM2,SW2,U1,V1	
		(CARBURETOR NO.)	(1)	-	-	-	BE61D A SD16	
	99101-ZF5-0600	JET, MAIN, #60 .....	1	-	-	-	BE12B A LD,LE,LW2,PM,PM2,QD,QE,QM,RD,SD,SE,SW2	
		(CARBURETOR NO.)	-	(1)	-	-	BE12B A	
	99101-ZH7-0600	/// .....	1	(1)	-	-	BE12B B LE,LW2,PM2,SW2,U1,V1	
		(CARBURETOR NO.)	1	-	-	-	LDB1,LD4	
			1	-	-	-	BE61D A SD16	
	99101-ZH8-0550	JET, MAIN, #55 .....	(1)	(1)	-	-	H1,L1,PM,QE,QM,Q1,R1,SE,S1,W1	
		(CARBURETOR NO.)	(1)	-	-	-	BE12B C LD,LDB3,LSJ4,QD,RD,RD4,SD,SDB1,SDB3,SD4,WMA3,WME4	
	99101-ZH8-0580	JET, MAIN, #58 .....	(1)	(1)	-	-	AR,DKR,H1,KR,KRA4,KRF4,KRS4,KRT,KRT4,KRT6,L1,PM,QE,QM,Q1,R1,SE S1,WM1,W1	
		(CARBURETOR NO.)	(1)	-	-	-	BE61D B SD16	
			(1)	-	-	-	BE12B C LD,LDB3,LSJ4,QD,RD,RD4,SD,SDB1,SDB3,SD4,WMA3,WME4	
	99101-ZH8-0600	JET, MAIN, #60 .....	1	(1)	-	-	BE12B B H1,L1,PM,QE,QM,Q1,R1,SE,S1,W1	
		(CARBURETOR NO.)	1	-	-	-	BE12B C WME4	
			1	-	-	-	BE12B B BE12B C LD,LDB3,LSJ4,QD,RD,RD4,SD,SDB1,SDB3,SD4,WMA3	
			(1)	-	-	-	AR,DKR,KR,KRA4,KRF4,KRS4,KRT,KRT4,KRT6,WM1	
			(1)	-	-	-	BE61D B SD16	
	99101-ZH8-0620	JET, MAIN, #62 .....	1	-	-	-	AR,DKR,KR,KRA4,KRF4,KRS4,KRT,KRT4,KRT6,WM1	
		(CARBURETOR NO.)	1	-	-	-	BE61D B SD16	
	99101-ZH8-0580	JET, MAIN, #58 .....	(1)	-	-	-	BE61D B LD,LDB3,LSJ4,QD,RD,RD4,SD,SDB1,SDB3,SD4,WMA3,WME4	
		(CARBURETOR NO.)	(1)	-	-	-	BE61D B LD,LDB3,LSJ4,QD,RD,RD4,SD,SDB1,SDB3,SD4,WMA3,WME4	
	99101-ZH8-0600	JET, MAIN, #60 .....	1	-	-	-	BE61D B LD,LDB3,LSJ4,QD,RD,RD4,SD,SDB1,SDB3,SD4,WMA3,WME4	
		(CARBURETOR NO.)	1	-	-	-	BE61D B LD,LDB3,LSJ4,QD,RD,RD4,SD,SDB1,SDB3,SD4,WMA3,WME4	
	99101-ZH8-0620	JET, MAIN, #62 .....	1	-	-	-	AR,DKR,KR,KRA4,KRF4,KRS4,KRT,KRT4,KRT6,LD,LDB1,LDB3,LD4,LE LSJ4,LW2,PM,PM2,QD,QE,QM,RD,RD4,SD,SDB1,SDB3,SD16,SD4,SE,SW2 WMA3,WME4,WM1	
33	99204-ZE0-0350	JET SET, PILOT, #35 .....	1	-	-	-		
			-	(1)	-	-		



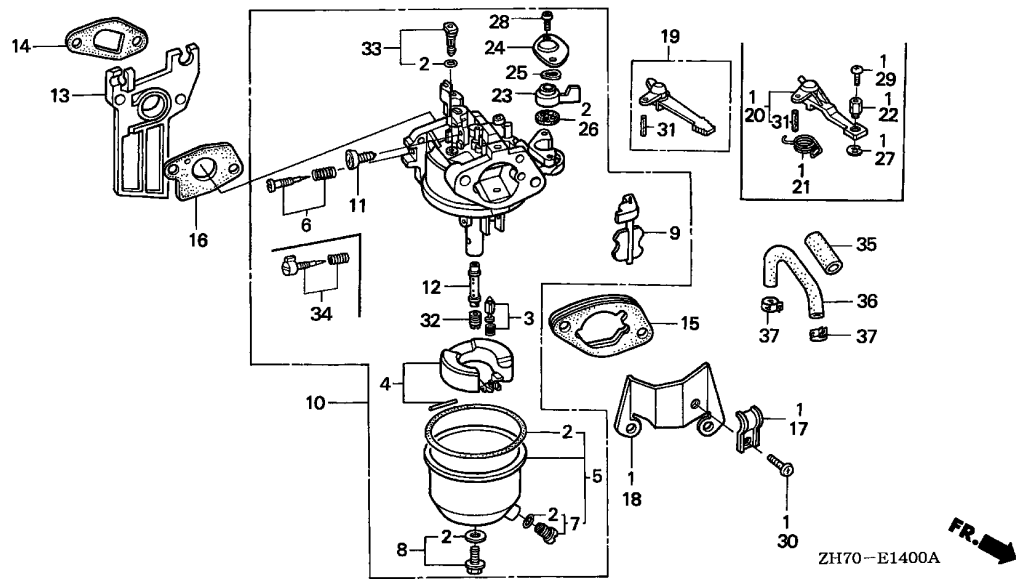

ZH70-E1400A

Ref. No.	Part No.	Description	Reqd. QTY				Serial No.	Parts catalogue code
			(1)	(2)	(3)	(4)		
34	16016-ZH7-W01	SCREW SET, PILOT (CARBURETOR NO.)	1	-	-	-	KRF4, KRS4	
		///	1	-	-	-	LD, LDB3, LSJ4, QD, RD, RD4, SD, SDB1, SDB3, SD16, SD4, WMA3, WME4, WM1	
		///	1	-	-	-	BE61D B ----- QE, SE	
35	16854-ZH8-000	RUBBER, SUPPORTER (107MM) ...	1	-	-	-	BE61G A ----- AR, DKR, KR, KRT, KRT4	
		///	1	-	-	-	BE62C A ----- AR, KRF4	
36	95001-45400-60	TUBE, FUEL, 4.5X400 (95001-45001-60M)	1	-	-	-	AR, KRF4	
37	95002-40800-08	CLAMP, TUBE (D8) .....	2	-	-	-	AR, KRF4	

2

# E-14-1

# CARBURETOR(2)

H11

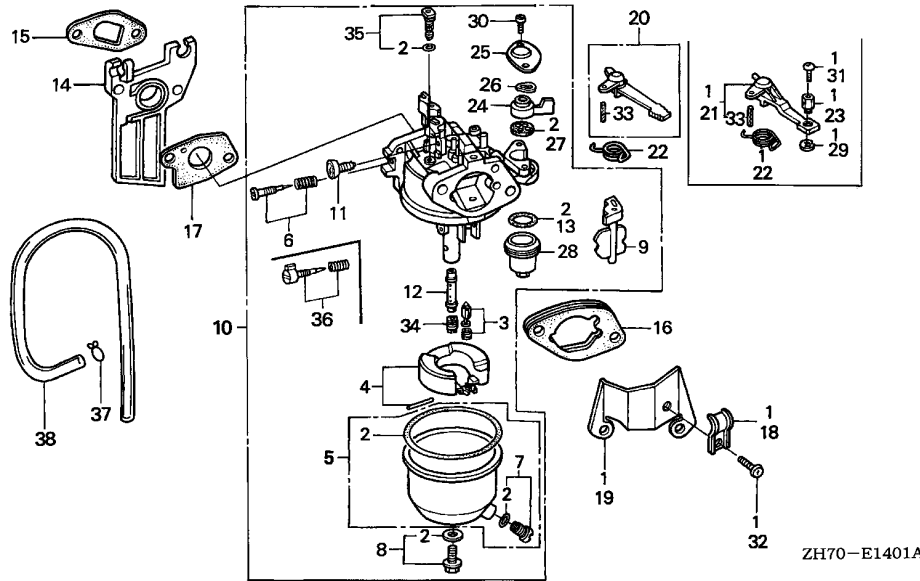

Ref. No.	L.O.N.	(Relative ref. Number) Description	F.R.T.
1	8101C4	CHOKE KIT, REMOTE CONTROL	0.2
2	3111B1	GASKET SET, CARBURETOR	0.3
3	3111E1	VALVE SET, FLOAT AND/OR FLOAT SET	0.3
6	3111D7	SCREW SET, PILOT	0.2
10	3111F3	CARBURETOR	0.2
14	3111C0	INSULATOR, CARBURETOR AND/OR PACKING, INSULATOR	0.2
17	3111C8	PACKING, CARBURETOR	0.2
20	8101F9	LEVER, CARBURETOR CHOKE	0.2
27	3101C5	PACKING, FUEL COCK	0.2
34	3111C3	JET, MAIN	0.3

Ref. No.	Part No.	Description	Reqd. QTY				Serial No.	Parts catalogue code
			(1)	(2)	(3)	(4)		
1	06164-ZE0-000	CHOKE KIT, REMOTE CONTROL	-	(1)	-	-	U1	
	06164-ZE1-000	.....	-	(1)	-	2377547	H1,L1,Q1,R1,S1,V1,W1	
2	16010-ZB1-015	GASKET SET	1	-	-	2377548	H1,L1,Q1,R1,S1,V1,W1	
	16010-ZE1-812	.....	1	-	-	-----	VMT,VPR4	
						-----	DS,EN,ET,ETX,HH,HHQ4,HTF2,HT2,HX,HXQ,HXU,HX2,HX26,HX4,LAJ4,LEH4,LH,LHQ4,LJ,LJC,LJD2,LJS,LJT,LSJ,LTA,LTJ,LTK1,LTR,LTS,LX,LXU,LX2,LX26,LX4,PH,PX,PX2,QA,QAA2,QA2,QA26,QBU2,QB26,QUEH,QHQ4,QH2,QH26,QJG2,QJW1,QLL,QMA4,QMA8,QME4,QMH,QMX2,QPU,QSJ,QT,QTC2,QWA4,QX,QXC,QXC9,QXG,QXG2,QXQ,QXS,QXS2,QXU,QX2,QX26,QX4,QX7,RH,RHC,RHQ4,RX,RX4,SAD2,SAJ,SAJ4,SCJ,SG24,SH,SHQ4,SJ,SJC,SJC1,SJC5,SJD2,SKJ,SKR,SMA7,SMJ,SMW2,SM11,SM12,SM14,SN,SSK1,SSK2,SSK3,SSX2,SSX4,STP,STS,SWX2,SWX4,SX,SXS4,SX4,SX7,TH,TX,TX2,TX26,TX4,UH,UX,UXU,VA,VAX4,VED,VED1,VED6,VEE1,VET,VEX,VEX7,VH,VMS4,VS,VSX,VSX1,VS1,VX,VXU,VX4,VX7,WDA6,WDJ,WD12,WJ,WJP,WJP1,WJ1,WKD6,WKT2,WKT4,WKT6,WME2	
	16010-ZH7-A20	.....	1	-	-	-----	VEK	
3	16011-ZE0-005	VALVE SET, FLOAT	1	-	-	-----	DS,EN,ET,ETX,HH,HHQ4,HTF2,HT2,HX,HXQ,HXU,HX2,HX26,HX4,LAJ4,LEH4,LH,LHQ4,LJ,LJC,LJD2,LJS,LJT,LSJ,LTA,LTJ,LTK1,LTR,LTS,LX,LXU,LX2,LX26,LX4,PH,PX,PX2,QA,QAA2,QA2,QA26,QBU2,QB26,QUEH,QHQ4,QH2,QH26,QJG2,QJW1,QLL,QMA4,QMA8,QME4,QMH,QMX2,QPU,QSJ,QT,QTC2,QWA4,QX,QXC,QXC9,QXG,QXG2,QXQ,QXS,QXS2,QXU,QX2,QX26,QX4,QX7,RH,RHC,RHQ4,RX,RX4,SAD2,SAJ,SAJ4,SCJ,SG24,SH,SHQ4,SJ,SJC,SJC1,SJC5,SJD2,SKJ,SKR,SMA7,SMJ,SMW2,SM11,SM12,SM14,SN,SSK1,SSK2,SSK3,SSX2,SSX4,STP,STS,SWX2,SWX4,SX,SXS4,SX4,SX7,TH,TX,TX2,TX26,TX4,UH,UX,UXU,VA,VAX4,VED,VED1,VED6,VEE1,VET,VEX,VEX7,VH,VMS4,VMT,VPR4,VS,VSX,VSX1,VS1,VX,VXU,VX4,VX7,WDA6,WDJ,WD12,WJ,WJP,WJP1,WJ1,WKD6,WKT2,WKT4,WKT6,WME2	
			-	(1)	1	1		



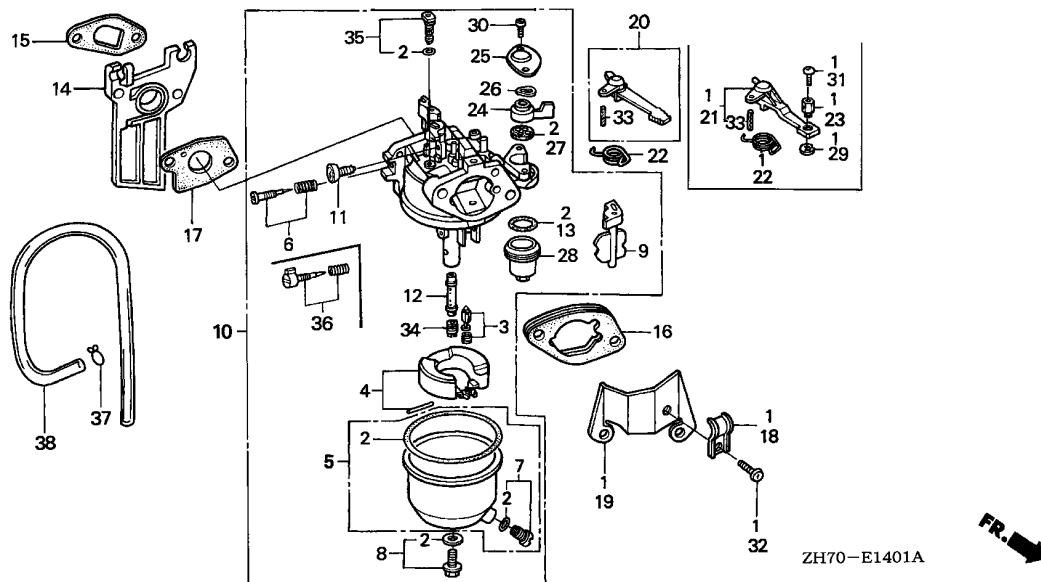

ZH70-E1401A

Ref. No.	Part No.	Description	Reqd. QTY				Serial No.	Parts catalogue code
			(1)	(2)	(3)	(4)		
4	16013-ZE0-005	FLOAT SET .....	1	-	-	-	-----	DS,EN,ET,ETX,HH,HHQ4,HTF2,HT2,HX,HXQ,HXU,HX2,HX26,HX4,LAJ4,LEH4,LH,LHQ4,LJ,LJC,LJD2,LJS,LJT,LSJ,LTA,LTJ,LTK1,LTR,LTS,LX,LXU,LX2,LX26,LX4,PH,PX,PX2,QA,QAA2,QA2,QA26,QBU2,QB26,QUEH,QHQ4,QH2,QH26,QJG2,QJW1,QLL,QMA4,QMA8,QME4,QMH,QMX2,QPU,QT,QT C2,QWA4,QX,QXC,QXC9,QXG,QXG2,QXQ,QXS,QXS2,QXU,QX2,QX26,QX4,QX7,RH,RHC,RHQ4,RX,RX4,SAD2,SAJ,SAJ4,SCJ,SG24,SH,SHQ4,SJ,SJC,SJC1,SJC5,SJD2,SKJ,SKR,SMA7,SMJ,SMW2,SM11,SM12,SM14,SN,SSK1,SSK2,SSK3,SSX2,SSX4,STP,STS,SWX2,SWX4,SX,SXS4, SX4, SX7, TH, TX, TX2, TX26, TX4, UH, UX, UXU, VA, VAX4, VED, VED1, VED6, VEE1, VEK, VET, VEX, VEX7, VH, VMS4, VMT, VPR4, VS, VSX, VSX1, VS1, VX, VXU, VX4, VX7, WDA6, WDJ, WD12, WJ, WJP, WJP1, WJ1, WKD6, WKT2, WKT4, WKT6, WME2
5	16015-ZE1-811	CHAMBER SET, FLOAT .....	1	(1)	1	-	-----	UIH,U1,VAX4
		(CARBURETOR NO.)	1	(1)	-	-	-----	BE12A B DS,EN,ET,ETX,HH,HHQ4,HX4,H1,LH,LHQ4,LJ,LTJ,LTR,LX,LX4,L1,PH,PX,QUEH,QH,QHQ4,QLL,QMA4,QMA8,QME4,QPU,QT,QX4,Q1,RH,RHC,RHQ4,RX,RX4,R1,SAJ,SCJ,SH,SHQ4,SJ,SJC,SKJ,SMA7,SMJ,SN,SSK1,SSK3,SSX4,STP,STS,SX, SX4, S1, TH, TX4, UH, UX, VA, VED, VED1, VET, VEX, VH, VS, VSX, VSX1, VS1, VX, VX4, V1, WDJ, WJ, WJP, WJP1, W1
	///		1	-	-	-	-----	BE12A A HX,QX,QXG,QXS,TX
	///		1	-	-	-	-----	BE13A A QXC
	///		1	-	-	-	-----	BE60A A HXQ,QXQ
	///		1	-	-	-	-----	BE60B A HTF2,HX2,HX26,LX2,LX26,PX2,QAA2,QBU2,QH2,QH26,QMX2,QT C2,QXG2,QXS2,QX2,QX26,SAD2,SG24,SMW2,SSK2,TX2,TX26
	///		1	-	-	-	-----	BE60C A QA2,QA26,WKT2,WME2
	///		1	-	-	-	-----	BE60F A QXC9
			-	-	-	1		

Ref. No.	Part No.	Description	Reqd. QTY				Serial No.	Parts catalogue code
			(1)	GX120K1 (2)	(3)	(4)		
(5)	16015-ZE0-831	CHAMBER SET, FLOAT .....	1	-	1	-	HT2, HXU, LAJ4, LEH4, LJC, LJD2, LJS, LJT, LSJ, LTA, LTK1, LTS, LXU, QA QB26, QIH1, QJG2, QJW1, QMH, QWA4, QXU, QX7, SAJ4, SJC1, SJC5, SJD2, SKR SM11, SM12, SM14, SSX2, SWX2, SWX4, SXS4, SX7, UXU, VED6, VEE1, VEX7, VMS4 VMT, VPR4, VXU, VX7, WDA6, WD12, WIH1, WJ1, WKD6, WKT4, WKT6	
		(CARBURETOR NO.)	1	-	1	-	BE12A C ----- DS, EN, ET, ETX, HH, HHQ4, HX4, LH, LHQ4, LJ, LTJ, LTR, LX, LX4, PH, PX, QEH QH, QHQ4, QLL, QMA4, QMA8, QME4, QPU, QT, QX4, RH, RHC, RHQ4, RX, RX4, SAJ SCJ, SH, SHQ4, SJ, SJC, SKJ, SMA7, SMJ, SN, SSK1, SSK3, SSX4, STP, STS, SX SX4, TH, TX4, UH, UIH, UX, VA, VED, VED1, VET, VEX, VH, VS, VSX, VSX1, VS1, VX VX4, WDJ, WJ, WJP, WJP1	
		//	1	-	-	-	BE12A B ----- HX, QX, QXG, QXS, TX	
		//	1	-	-	-	BE13A B ----- QXC	
		//	1	-	-	-	BE60A B ----- HXQ, QXQ	
		//	1	-	-	-	BE60B B ----- HTF2, HX2, HX26, LX2, LX26, PX2, QAA2, QBU2, QH2, QH26, QMX2, QTC2, QXG2 QXS2, QX2, QX26, SAD2, SG24, SMW2, SSK2, TX2, TX26	
		//	1	-	-	-	BE60C B ----- QA2, QA26, WKT2, WME2	
		//	1	-	-	-	BE60F B ----- QXC9	
		(CARBURETOR NO.)	-	(1)	-	-	BE12A C	
	16015-ZH7-A21	.....	1	-	-	-	VEK	
6	16016-ZE0-005	SCREW SET, PILOT .....	1	-	-	-	EN, ET, ETX, HH, LJC, LTA, LTK1, QA, QLL, QME4, QT, QXG, QXS, RH, RHC, SN, STP STS, VA, VAX4, VEK, VH, VMT, VPR4, VSX, VSX1, VS1	
		(CARBURETOR NO.)	1	-	-	-	BE60M A ----- QB26	
		//	1	-	-	-	BE12A B QXC	
		//	1	-	-	-	BE12A C HHQ4, HX, HXU, HX4, LAJ4, LEH4, LH, LHQ4, LJT, LX, LXU, LX4, PH, PX, QEH, QH QHQ4, QJW1, QMA4, QMA8, QMH, QPU, QX, QXU, QX4, RHQ4, RX, RX4, SAJ4, SH SHQ4, SMA7, SMJ, SSK1, SSK3, SSX4, SX, SX4, TH, TX, TX4, UH, UX, UXU, VEX VMS4, VS, VX, VXU, VX4	
		//	1	-	-	-	BE60K A WJ1	
		//	1	-	-	-	BE60L A DS, LJ, LSJ, LTJ, LTR, SAJ, SCJ, SJ, SJC, SJC1, SJC5, SKJ, SKR, VED, VED1 VEE1, VET, WDJ, WJ, WJP, WJP1	
		(CARBURETOR NO.)	-	(1)	1	-	BE12A C	
7	16024-ZE1-811	SCREW SET, DRAIN .....	1	-	-	-	DS, EN, ET, ETX, HH, HHQ4, HTF2, HT2, HX, HXQ, HXU, HX2, HX26, HX4, LAJ4 LEH4, LH, LHQ4, LJ, LJC, LJD2, LJS, LJT, LSJ, LTA, LTJ, LTK1, LTR, LTS, LX LXU, LX2, LX26, LX4, PH, PX, PX2, QA, QAA2, QA2, QA26, QBU2, QB26, QEH, QH QHQ4, QH2, QH26, QJG2, QJW1, QLL, QMA4, QMA8, QME4, QMH, QMX2, QPU, QSJ, QT QTC2, QWA4, QX, QXC, QXC9, QXG, QXG2, QXQ, QXS, QXS2, QXU, QX2, QX26, QX4 QX7, RH, RHC, RHQ4, RX, RX4, SAD2, SAJ, SAJ4, SCJ, SG24, SH, SHQ4, SJ, SJC SJC1, SJC5, SJD2, SKJ, SKR, SMA7, SMJ, SMW2, SM11, SM12, SM14, SN, SSK1 SSK2, SSK3, SSX2, SSX4, STP, STS, SWX2, SWX4, SX, SXS4, SX4, SX7, TH, TX TX2, TX26, TX4, UH, UX, UXU, VA, VAX4, VED, VED1, VED6, VEE1, VET, VEX, VEX7 VH, VMS4, VMT, VPR4, VS, VSX, VSX1, VS1, VX, VXU, VX4, VX7, WDA6, WDJ, WD12 WJ, WJP, WJP1, WJ1, WKD6, WKT2, WKT4, WKT6, WME2	
		(CARBURETOR NO.)	-	(1)	1	1	VEK	
	16024-ZH7-A20	.....	1	-	-	-	VEK	
8	16028-ZE0-005	SCREW SET .....	1	-	-	-	DS, EN, ET, ETX, HH, HHQ4, HTF2, HT2, HX, HXQ, HXU, HX2, HX26, HX4, LAJ4 LEH4, LH, LHQ4, LJ, LJC, LJD2, LJS, LJT, LSJ, LTA, LTJ, LTK1, LTR, LTS, LX LXU, LX2, LX26, LX4, PH, PX, PX2, QA, QAA2, QA2, QA26, QBU2, QB26, QEH, QH QHQ4, QH2, QH26, QJG2, QJW1, QLL, QMA4, QMA8, QME4, QMH, QMX2, QPU, QSJ, QT QTC2, QWA4, QX, QXC, QXC9, QXG, QXG2, QXQ, QXS, QXS2, QXU, QX2, QX26, QX4 QX7, RH, RHC, RHQ4, RX, RX4, SAD2, SAJ, SAJ4, SCJ, SG24, SH, SHQ4, SJ, SJC SJC1, SJC5, SJD2, SKJ, SKR, SMA7, SMJ, SMW2, SM11, SM12, SM14, SN, SSK1 SSK2, SSK3, SSX2, SSX4, STP, STS, SWX2, SWX4, SX, SXS4, SX4, SX7, TH, TX TX2, TX26, TX4, UH, UX, UXU, VA, VAX4, VED, VED1, VED6, VEE1, VET, VEX, VEX7, VH, VMS4, VMT, VPR4, VS, VSX, VSX1, VS1, VX, VXU, VX4, VX7, WDA6, WDJ WD12, WJ, WJP, WJP1, WJ1, WKD6, WKT2, WKT4, WKT6, WME2	
		(CARBURETOR NO.)	-	(1)	1	1	VEK	



E-14-1

CARBURETOR(2)

H14

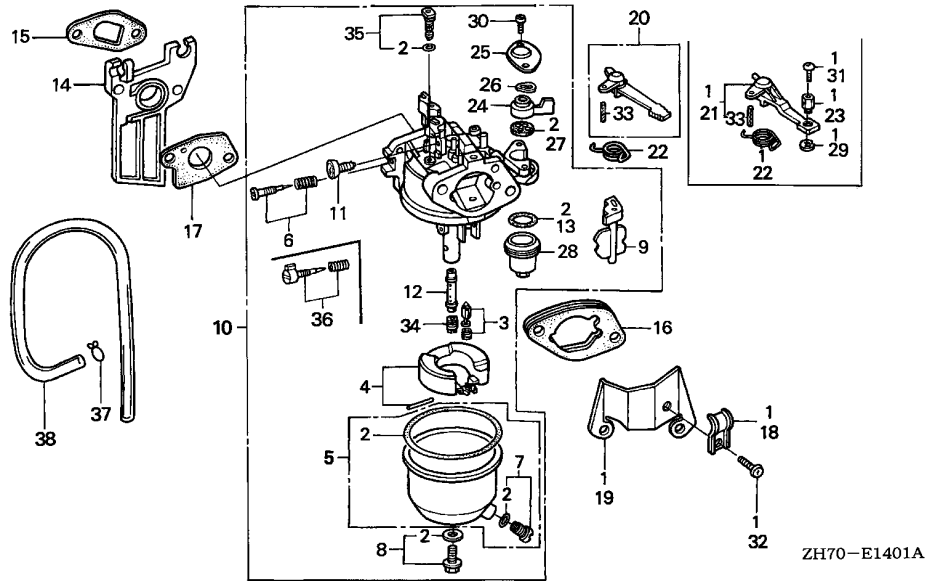

Ref. No.	Part No.	Description	Reqd. QTY				Serial No.	Parts catalogue code
			(1)	(2)	(3)	(4)		
9	16044-ZE0-005	CHOKE SET .....	1	-	1	-	-----	HHQ4,HTF2,HT2,HXQ,HXU,HX2,HX26,HX4,LAJ4,LEH4,LHQ4,LJC,LJD2,LJS LJT,LSJ,LTA,LTK1,LTR,LTS,LXU,LX2,LX26,LX4,PX2,QAA2,QA2,QA26 QBU2,QB26,QHQ4,QH2,QH26,QIH1,QJG2,QJW1,QLL,QMA4,QMA8,QME4,QMH QMX2,QSJ,QTC2,QWA4,QXC9,QXG2,QXQ,QXS2,QXU,QX2,QX26,QX4,QX7 RHQ4,RX4,SAD2,SAJ,SAJ4,SCJ,SG24,SHQ4,SJC,SJC1,SJC5,SJD2,SKR SMA7,SMW2,SM11,SM12,SM14,SSK1,SSK2,SSK3,SSX2,SSX4,STP,SWX2 SWX4,SXS4,SX4,SX7,TX2,TX26,TX4,UXU,VAX4,VED6,VEE1,VEK,VEX7 VMS4,VMT,VPR4,VXU,VX4,VX7,WDA6,WDJ,WD12,WIH1,WJP,WJP1,WJ1,WKD6 WKT2,WKT4,WKT6,WME2
		(CARBURETOR NO.)	1	-	1	-	BE12A B -----	DS,EN,ET,ETX,HH,HX,LH,LJ,LTJ,LX,PH,PX,QEH,QH,QPU,QT,QX,QXG,QXS RH,RHC,RX,SH,SJ,SKJ,SMJ,SN,SX,TH,TX,UH,UIH,UX,VA,VED,VED1,VET VEX,VH,VS,VSX,VSX1,VS1,VX,WJ
		///	1	-	-	-	BE13A B -----	QXC
		///	-	(1)	-	-	BE12A B -----	
10	16100-ZH7-V90	CARBURETOR ASSY. (BE12K A) ..	1	-	-	-	2733193	LTA
	16100-ZH7-W02	CARBURETOR ASSY. (BE60A A) ..	1	-	-	-	2724100	HXQ,QXQ
	16100-ZH7-W50	CARBURETOR ASSY. (BE60B A) ..	1	-	-	-	2728507	HTF2,HX2,LX2,FX2,QAA2,QH2,QMX2,QXG2,QXS2,QX2,SMW2,SSK2,TX2
	16100-ZH7-800	CARBURETOR ASSY. (BE13A A) ..	1	(1)	-	-	2724424	H1,L1,QXC,Q1,R1,S1,V1,W1
			1	-	-	-	2733193	STS
			-	(1)	-	-	-----	U1
	16100-ZH7-801	CARBURETOR ASSY. (BE13A B) ..	1	-	-	-	2724425	3491424 QXC
	16100-ZH7-820	CARBURETOR ASSY. (BE12A A) ..	1	-	-	-	2354880	DS,EN,ET,ETX,HH,HX,LH,LJ,LTJ,LX,PH,PX,QEH,QH,QPU,QT,QX,QXG,QXS RH,RHC,RX,SH,SJ,SKJ,SMJ,SN,SX,TH,TX,UH,UX,VA,VED,VED1,VET VH,VS,VSX,VSX1,VS1,VX,WJ
			-	(1)	-	-	2354880	-----
			-	-	1	-	-----	UIH
			-	-	-	1	-----	

E-14-1

CARBURETOR(2)

H15

Ref. No.	Part No.	Description	Reqd. QTY				Serial No.	Parts catalogue code
			(1)	GX120K1 (2)	(3)	(4)		
10)	16100-ZH7-821	CARBURETOR ASSY. (BE12A B) ..	1	(1)	-	-	2354881 2724891	DS,EN,ET,ETX,HH,HX,H1,LH,LJ,LTJ,LX,L1,PH,PX,QEH,QH,QPU,QT,QX,QXG,QXS,Q1,RH,RHC,RX,R1,SH,SJ,SKJ,SMJ,SN,SX,S1,TH,TX,UH,UX,VA,VED,VED1,VET,VEX,VH,VS,VSX,VSX1,VS1,VX,V1,WJ,W1
			1	-	-	-	2724891	HHQ4,HX4,LHQ4,LX4,QHQ4,QLL,QMA4,QMA8,QME4,QX4,RHQ4,RX4,SAJ,SCJ,SHQ4,SJC,SMA7,SSK1,SSK3,SSX4,STP,SX4,TX4,VAX4,VX4,WDJ,WJP
			-	(1)	-	-	2354881	U1
			-	-	1	-		UIH
	16100-ZH7-822	CARBURETOR ASSY. (BE12A C) ..	1	(1)	-	-	2724892	HH,H1,L1,QLL,QXG,QXS,Q1,RH,RHC,R1,STP,S1,VA,VAX4,VH,VSX,VSX1,VS1,V1,W1
			1	-	-	-	3056056	LSJ,LTR,QSJ,SJC1,SJC5,VEE1,WJP1
			1	-	-	-	3491424	HXU,LAJ4,LEH4,LJT,LXU,QJW1,QMH,QXU,SAJ4,UXU,VMS4,VXU
			1	-	-	-	2724892	DS,EN,ET,ETX,LJ,LTJ,QME4,QT,SAJ,SCJ,SJ,SJC,SN,VED,VED1,VET,WDJ,WJ,WJP
			1	-	-	-	2724892	3491424 HHQ4,HX,HX4,LH,LHQ4,LX,LX4,PH,PX,QEH,QH,QHQ4,QMA4,QMA8,QPU,QX,QX4,RHQ4,RX,RX4,SH,SHQ4,SMA7,SMJ,SSK1,SSK3,SSX4,SX,SX4,TH,TX,TX4,UH,UX,VEX,VS,VX,VX4
			-	-	1	-		UIH
	16100-ZH7-830	CARBURETOR ASSY. (BE12C A) ..	1	(1)	-	-	2743606	H1,L1,QA,Q1,R1,S1,V1,W1
			-	(1)	-	-		U1
	16100-ZH7-831	CARBURETOR ASSY. (BE12C B) ..	1	(1)	-	-	2743607	H1,L1,QA,Q1,R1,S1,V1,W1
	16100-ZH7-V21	CARBURETOR ASSY. (BE60F B) ..	1	-	-	-	3491425	QXC
	16100-ZH7-V91	CARBURETOR ASSY. (BE12K B) ..	1	-	-	-	2733194	LTA
	16100-ZH7-W03	CARBURETOR ASSY. (BE60A B) ..	1	-	-	-	2724101	HXQ,QXQ
	16100-ZH7-W50	CARBURETOR ASSY. (BE60B A) ..	1	-	-	-	2728507	HX26,LX26,QBU2,QH26,QTC2,QX26,SAD2,SG24,TX26
	16100-ZH7-W51	CARBURETOR ASSY. (BE60B B) ..	1	-	-	-	2728508	HT2,LJD2,LTS,QJG2,QWA4,QX7,SJD2,SM11,SM12,SM14,SSX2,SWX2,SWX4,SXS4, SX7,VEX7,VX7,WDA6
			1	-	-	-	2728508	HTF2,HX2,HX26,LX2,LX26,PX2,QAA2,QBU2,QH2,QH26,QMX2,QTC2,QXG2,QXS2,QX2,QX26,SAD2,SG24,SMW2,SSK2,TX2,TX26
			1	-	-	-	3093871	VEE1
			1	-	-	-	3491425	HHQ4,HX,HXU,HX4,LAJ4,LEH4,LH,LHQ4,LJT,LX,LXU,LX4,PH,PX,QEH,QH,QHQ4,QJW1,QMA4,QMA8,QMH,QPU,QX,QXU,QX4,RHQ4,RX,RX4,SAJ4,SH,SHQ4,SMA7,SMJ,SSK1,SSK3,SSX4,SX,SX4,TH,TX,TX4,UH,UX,UXU,VEX,VMS4,VS,VX,VXU,VX4
			1	-	-	-	3558049	LTJ
			1	-	-	-	3230227	QB26
	16100-ZH7-W60	CARBURETOR ASSY. (BE60C A) ..	1	-	-	-	2737528	QA2,QA26,WKT2,WME2
	16100-ZH7-801	CARBURETOR ASSY. (BE13A B) ..	1	-	-	-	2733194	STS
			-	(1)	-	-	2724425	H1,L1,Q1,R1,S1,V1,W1
	16100-ZH7-V20	CARBURETOR ASSY. (BE60F A) ..	1	-	-	-	2724100	QXC9
	16100-ZH7-W61	CARBURETOR ASSY. (BE60C B) ..	1	-	-	-	2737529	LJS,VED6,WD12,WKD6,WKT4,WKT6
			1	-	-	-	2737529	QA2,QA26,WKT2,WME2
			1	-	-	-	3491425	DS,LJ,LSJ,LTR,SAJ,SCJ,SJ,SJC,SJC1,SJC5,SKJ,SKR,VED,VED1,VET,WDJ,WJ,WJP,WJP1,WJ1
	16100-ZH7-841	CARBURETOR ASSY. (BE60L A) ..	1	-	-	-	3491425	3558048 LTJ
			1	-	-	-		LJC,LTK1
			1	-	-	-	3056057	EN,ET,ETX,QME4,QSJ,QT,SN
			1	-	-	-	3491424	SKR
			1	-	-	-	3056057	3093870 VEE1
			1	-	-	-	3056057	3491424 DS,LJ,LSJ,LTJ,LTR,SAJ,SCJ,SJ,SJC,SJC1,SJC5,SKJ,VED,VED1,VET,WDJ,WJ,WJP,WJP1
			-	-	1	-		
	16100-ZH7-V21	CARBURETOR ASSY. (BE60F B) ..	1	-	-	-	2724101	QXC9
	16100-ZK7-U51	CARBURETOR ASSY. (BE60M A) ..	1	-	-	-	3230226	QB26
	16100-ZK7-811	CARBURETOR ASSY. (BE60K A) ..	1	-	-	-	3491424	WJ1
	16100-ZH7-T01	CARBURETOR ASSY. (BE12H B) ..	1	-	-	-		VEK
	16100-ZK7-U51	CARBURETOR ASSY. (BE60M A) ..	1	-	-	-	3323433	QB26

2



E-14-1

CARBURETOR(2)

H16

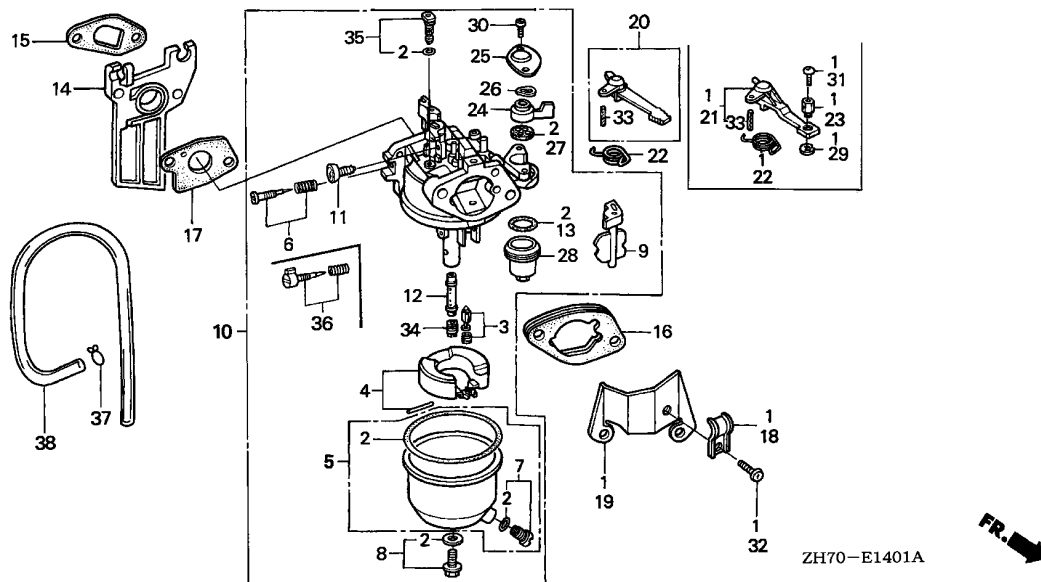

Ref. No.	Part No.	Description	Reqd. QTY				Serial No.	Parts catalogue code
			(1)	(2)	(3)	(4)		
10)	16100-ZK7-U11	CARBURETOR ASSY. (BE28B A) ..	1	-	-	-	-----	VMT,VPR4
11	16124-ZE0-005	SCREW, THROTTLE STOP .....	1	-	-	-	-----	DS,EN,ET,ETX,HH,HHQ4,HTF2,HT2,HX,HXQ,HXU,HX2,HX26,HX4,LAJ4,LEH4,LH,LHQ4,LJ,LJC,LJD2,LJS,LJT,LSJ,LTA,LTJ,LTK1,LTR,LTS,LX,LXU,LX2,LX26,LX4,PH,PX,PX2,QA,QAA2,QA2,QA26,QBU2,QB26,QUEH,QHQ4,QH2,QH26,QJG2,QJW1,QLL,QMA4,QMA8,QME4,QMH,QMX2,QPU,QSJ,QT,QTC2,QWA4,QX,QXC,QXC9,QXG,QXG2,QXQ,QXS,QXS2,QXU,QX2,QX26,QX4,QX7,RH,RHC,RHQ4,RX,RX4,SAD2,SAJ,SAJ4,SCJ,SG24,SH,SHQ4,SJ,SJC,SJC1,SJC5,SJD2,SKJ,SKR,SMA7,SMJ,SMW2,SM11,SM12,SM14,SN,SSK1,SSK2,SSK3,SSX2,SSX4,STP,STS,SWX2,SWX4,SX,SXS4,SX4,SX7,TH,TX,TX2,TX26,TX4,UH,UX,UXU,VA,VAX4,VED,VED1,VED6,VEE1,VEK,VET,VEX,VEX7,VH,VMS4,VMT,VPR4,VS,VSX,VSX1,VS1,VX,VXU,VX4,VX7,WDA6,WDJ,WD12,WJ,WJP,WJP1,WJ1,WKD6,WKT2,WKT4,WKT6,WME2
12	16166-ZH7-800	NOZZLE, MAIN .....	1	-	-	1	-----	STS
		(CARBURETOR NO.)	1	-	-	-	-----	BE13A B QXC
	16166-ZH7-820	.....	-	(1)	-	-	-----	
		(CARBURETOR NO.)	1	-	1	-	-----	BE12A A DS,EN,ET,ETX,HH,HX,LH,LJ,LTJ,LX,PH,PX,QUEH,QH,QPU,QT,QX,QXG,QXS,RH,RHC,RX,SH,SJ,SKJ,SMJ,SN,SX,TH,TX,UH,UIH,UX,VA,VED,VED1,VET,VEX,VH,VS,VSX,VSX1,VS1,VX,WJ
		(CARBURETOR NO.)	1	-	-	-	-----	LTA,QA,VEK
		(CARBURETOR NO.)	-	(1)	-	-	-----	
		(CARBURETOR NO.)	-	-	-	1	-----	BE12A A
	16166-ZH7-V20	.....	1	-	-	-	-----	QXC9
		(CARBURETOR NO.)	1	-	-	-	-----	BE60F B QXC
	16166-ZH7-W00	.....	1	-	-	-	-----	HXQ,QXQ

E-14-1

CARBURETOR(2)

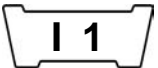

Ref. No.	Part No.	Description	Reqd. QTY				Serial No.	Parts catalogue code
			(1)	GX120K1 (2)	(3)	(4)		
12)	16166-ZH7-W50	NOZZLE, MAIN .....	1	-	1	-	-----	HHQ4,HTF2,HT2,HXU,HX2,HX26,HX4,LAJ4,LEH4,LHQ4,LJC,LJD2,LJS,LJT,LSJ,LTK1,LTR,LTS,LXU,LX2,LX26,LX4,PX2,QAA2,QA2,QA26,QBU2,QB26,QHQ4,QH2,QH26,QIH1,QJG2,QJW1,QLL,QMA4,QMA8,QME4,QMH,QMX2,QSJ,QTC2,QWA4,QXG2,QXS2,QXU,QX2,QX26,QX4,QX7,RHQ4,RX4,SAD2,SAJ,SAJ4,SCJ,SG24,SHQ4,SJC,SJC1,SJC5,SJD2,SKR,SMA7,SMW2,SM11,SM12,SM14,SSK1,SSK2,SSK3,SSX2,SSX4,STP,SWX2,SWX4,SXS4,SX4,SX7,TX2,TX26,TX4,UXU,VAX4,VED6,VEE1,VEX7,VMS4,VMT,VPR4,VXU,VX4,VX7,WDA6,WDJ,WD12,WIH1,WJP,WJP1,WJ1,WKD6,WKT2,WKT4,WKT6,WME2
		(CARBURETOR NO.)	1	-	1	-	BE12A B	DS,EN,ET,ETX,HH,HX,LH,LJ,LTJ,LX,PH,PX,QUEH,QH,QPU,QT,QX,QXG,QXS,RH,RHC,RX,SH,SJ,SKJ,SMJ,SN,SX,TH,TX,UH,UIH,UX,VA,VED,VED1,VET,VEX,VH,VS,VSX,VSX1,VS1,VX,WJ
13	16173-001-004	PACKING, FUEL STRAINER CUP ..	-	(1)	-	1	BE12A B	
			1	-	-	-	-----	DS,EN,ET,ETX,HH,HHQ4,HTF2,HT2,HX,HXQ,HXU,HX2,HX26,HX4,LAJ4,LEH4,LH,LHQ4,LJ,LJC,LJD2,LJS,LJT,LSJ,LTA,LTJ,LTK1,LTR,LTS,LX,LXU,LX2,LX26,LX4,PH,PX,PX2,QA,QAA2,QA2,QA26,QBU2,QB26,QUEH,QH,QHQ4,QH2,QH26,QJG2,QJW1,QLL,QMA4,QMA8,QME4,QMH,QMX2,QPU,QSJ,QT,QTC2,QWA4,QX,QXC,QXC9,QXG,QXG2,QXQ,QXS,QXS2,QXU,QX2,QX26,QX4,QX7,RH,RHC,RHQ4,RX,RX4,SAD2,SAJ,SAJ4,SCJ,SG24,SH,SHQ4,SJ,SJC,SJC1,SJC5,SJD2,SKJ,SKR,SMA7,SMJ,SMW2,SM11,SM12,SM14,SN,SSK1,SSK2,SSK3,SSX2,SSX4,STP,STS,SWX2,SWX4,SX,SXS4,SX4,SX7,TH,TX,TX2,TX26,TX4,UH,UX,UXU,VA,VAX4,VED,VED1,VED6,VEE1,VEK,VET,VEX,VEX7,VH,VMS4,VS,VSX,VSX1,VS1,VX,VXU,VX4,VX7,WDA6,WDJ,WD12,WJ,WJP,WJP1,WJ1,WKD6,WKT2,WKT4,WKT6,WME2
14	16211-ZE0-000	INSULATOR, CARBURETOR .....	-	(1)	1	1	-----	
			1	-	-	-	-----	DS,EN,ET,ETX,HH,HHQ4,HTF2,HT2,HX,HXQ,HXU,HX2,HX26,HX4,LAJ4,LEH4,LH,LHQ4,LJ,LJC,LJD2,LJS,LJT,LSJ,LTA,LTJ,LTK1,LTR,LTS,LX,LXU,LX2,LX26,LX4,PH,PX,PX2,QA,QAA2,QA2,QA26,QBU2,QB26,QUEH,QH,QHQ4,QH2,QH26,QJG2,QJW1,QLL,QMA4,QMA8,QME4,QMH,QMX2,QPU,QSJ,QT,QTC2,QWA4,QX,QXC,QXC9,QXG,QXG2,QXQ,QXS,QXS2,QXU,QX2,QX26,QX4,QX7,RH,RHC,RHQ4,RX,RX4,SAD2,SAJ,SAJ4,SCJ,SG24,SH,SHQ4,SJ,SJC,SJC1,SJC5,SJD2,SKJ,SKR,SMA7,SMJ,SMW2,SM11,SM12,SM14,SN,SSK1,SSK2,SSK3,SSX2,SSX4,STP,STS,SWX2,SWX4,SX,SXS4,SX4,SX7,TH,TX,TX2,TX26,TX4,UH,UX,UXU,VA,VAX4,VED,VED1,VED6,VEE1,VEK,VET,VEX,VEX7,VH,VMS4,VMT,VPR4,VS,VSX,VSX1,VS1,VX,VXU,VX4,VX7,WDA6,WDJ,WD12,WJ,WJP,WJP1,WJ1,WKD6,WKT2,WKT4,WKT6,WME2
15	16212-ZH7-000	PACKING, INSULATOR .....	-	1	1	1	-----	2272434 DS,EN,ET,ETX,LJ,LTA,QT,SJ,SKJ,SMJ,SN,STS,VET,WJ
	16212-ZH7-800	.....	-	(1)	-	-	-----	2272434
			1	-	-	-	-----	HH,HHQ4,HTF2,HT2,HX,HXQ,HXU,HX2,HX26,HX4,LAJ4,LEH4,LH,LHQ4,LJC,LJD2,LJS,LJT,LSJ,LTJ,LTK1,LTR,LTS,LX,LXU,LX2,LX26,LX4,PH,PX,PX2,QA,QAA2,QA2,QA26,QBU2,QB26,QUEH,QH,QHQ4,QH2,QH26,QJG2,QJW1,QLL,QMA4,QMA8,QME4,QMH,QMX2,QPU,QSJ,QTC2,QWA4,QX,QXC,QXC9,QXG,QXG2,QXQ,QXS,QXS2,QXU,QX2,QX26,QX4,QX7,RH,RHC,RHQ4,RX,SAJ,SAJ4,SCJ,SG24,SH,SHQ4,SJC,SJC1,SJC5,SJD2,SKR,SMA7,SMW2,SM11,SM12,SM14,SSK1,SSK2,SSK3,SSX2,SSX4,STP,SWX2,SWX4,SX,SXS4,SX4,SX7,TH,TX,TX2,TX26,TX4,UH,UX,UXU,VA,VAX4,VED,VED1,VED6,VEE1,VEK,VEX,VEX7,VH,VMS4,VMT,VPR4,VS,VSX,VSX1,VS1,VX,VXU,VX4,VX7,WDA6,WDJ,WD12,WJP,WJP1,WJ1,WKD6,WKT2,WKT4,WKT6,WME2
			1	-	-	-	2272435	-----
			-	(1)	-	-	2272435	-----
			-	-	1	1		
16	16220-ZE1-004	SPACER COMP., CARBURETOR ....	-	-	1	-		



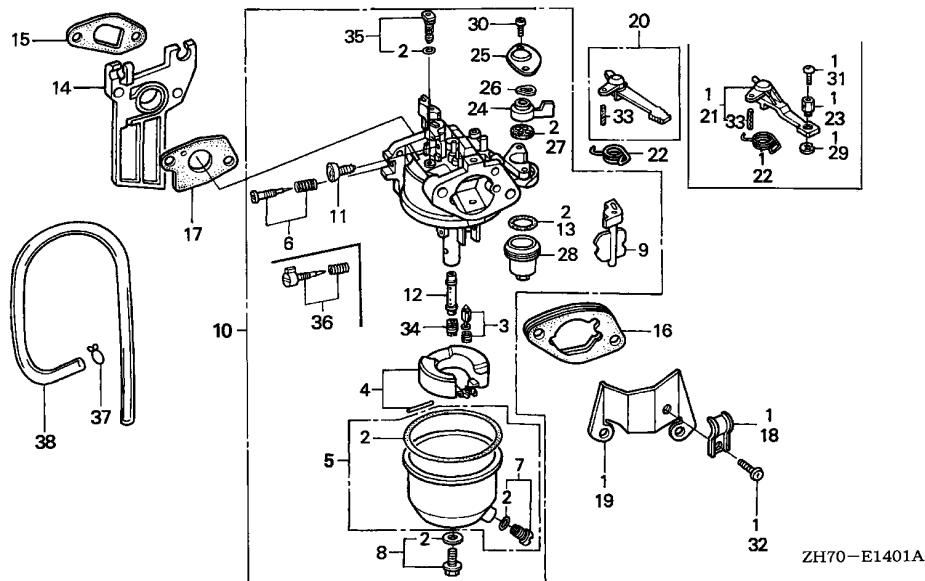

Ref. No.	Part No.	Description	Reqd. QTY				Serial No.	Parts catalogue code
			(1)	(2)	(3)	(4)		
16)	16220-ZE1-020	SPACER COMP., CARBURETOR .....	1	-	1	-	-----	DS,EN,ET,ETX,HH,HHQ4,HTF2,HT2,HX,HXQ,HXU,HX2,HX26,HX4,LAJ4,LEH4,LH,LHQ4,LJ,LJC,LJD2,LJS,LJT,LSJ,LTA,LTJ,LTK1,LTR,LTS,LX,LXU,LX2,LX26,LX4,PH,PX,PX2,QA,QAA2,QA2,QA26,QBU2,QB26,QEH,QH,QHQ4,QH2,QH26,QJG2,QJW1,QLL,QMA4,QMA8,QME4,QMH,QMX2,QPU,QSJ,QT,QT C2,QWA4,QX,QXC,QXC9,QXG,QXG2,QXQ,QXS,QXS2,QXU,QX2,QX26,QX4,QX7,RH,RHC,RHQ4,RX,RX4,SAD2,SAJ,SAJ4,SCJ,SG24,SH,SHQ4,SJ,SJC,SJC1,SJC5,SJD2,SKJ,SKR,SMA7,SMJ,SMW2,SM11,SM12,SM14,SN,SSK1,SSK2,SSK3,SSX2,SSX4,STP,STS,SWX2,SWX4,SX,SXS4, SX4, SX7, TH, TX, TX2, TX26, TX4, UH, UIH, UX, UXU, VA, VAX4, VED, VED1, VED6, VEE1, VEK, VET, VEX, VEX7, VH, VMS4, VS, VSX, VSX1, VS1, VX, VXU, VX4, VX7, WDA6, WDJ, WD12, WIH1, WJ, WJP, WJP1, WJ1, WKD6, WKT2, WKT4, WKT6, WME2
17	16221-ZE0-000	PACKING, CARBURETOR .....	1	-	1	-	-----	QA, QXC
	16221-ZE1-000	.....	1	-	1	-	-----	HH, HX, HXU, LH, LX, LXU, PH, PX, QEH, QH, QX, QXU, RH, RX, SH, SX, TH, UH, UIH, UX, UXU, VA, VH, VS, VSX, VXU
			1	-	-	-	2272434	DS, EN, ET, ETX, LJ, LTA, QT, SJ, SKJ, SMJ, SN, STS, VET, WJ
			1	-	-	-	2533057	VED, VED1
			-	(1)	-	-	2272434	
	16221-ZH8-800	.....	1	(1)	1	-	-----	2533057 H1, L1, QA, QLL, QPU, Q1, RHC, R1, S1, UIH, VEX, VSX1, VS1, V1, W1
			1	-	-	-	-----	2386441 QHQ4, SHQ4
			1	-	-	-	-----	2534176 LTJ, LX, PH, PX, RX, SCJ, SSK1, SX, TH, UH, UX, VH, VX, WJP
			1	-	-	-	-----	2539585 HXQ, HX2, LX2, QAA2, QA2, QH2, QXG2, QXQ, QXS2, QX2, TX2
			1	-	-	-	-----	2541043 HHQ4, HX4, LHQ4, LX4, QX4, RHQ4, RX4, SX4, TX4, VX4
			1	-	-	-	-----	2541695 HX, QX, QXG, QXS, TX
			1	-	-	2272435	-----	EN, ET, ETX, QT, SN
			1	-	-	2272435	-----	2534176 DS, LJ, LTA, SJ, SKJ, SMJ, STS, VET, WJ
			-	(1)	-	-	-----	U1
			-	-	-	1	-----	2533057

Ref. No.	Part No.	Description	Reqd. QTY			Serial No.	Parts catalogue code
			(1)	(2)	(3)		
17)	16221-ZH8-801	PACKING, CARBURETOR .....	1	(1)	1	-	2533058 ----- EN,ET,ETX,H1,L1,QA,QLL,QPU,QT,Q1,RHC,R1,SN,S1,UIH,VED,VED1,VEX VSX1,VS1,V1,W1
			1	-	1	-	----- HTF2,HT2,HX26,LAJ4,LEH4,LJC,LJD2,LJS,LJT,LSJ,LTK1,LTR,LTS,LX26 PX2,QA26,QBU2,QB26,QH26,QIH1,QJG2,QJW1,QMA4,QMA8,QME4,QMH,QMX2 QTC2,QWA4,QXC9,QX26,QX7,SAD2,SAJ,SAJ4,SG24,SJC,SJC5,SJD2,SKR SMA7,SMW2,SM11,SM12,SM14,SSK2,SSK3,SSX2,SSX4,STP,SWX2,SWX4 SXS4, SX7, TX26, VAX4, VED6, VEE1, VEK, VEX7, VMS4, VMT, VPR4, VX7, WDA6 WDJ,WD12,WIH1,WJP1,WJ1,WKD6,WKT2,WKT4,WKT6,WME2
			1	-	-	-	2386442 ----- QHQ4,SHQ4
			1	-	-	-	2534177 ----- DS,LJ,LTA,LTJ,LX,PH,PX,RX,SCJ,SJ,SKJ,SMJ,SSK1,STS,SX,TH,UH,UX VET,VH,VX,WJ,WJP
			1	-	-	-	2539586 ----- HXQ,HX2,LX2,QAA2,QA2,QH2,QXG2,QXQ,QXS2,QX2, TX2
			1	-	-	-	2541044 ----- HHQ4,HX4,LHQ4,LX4,QX4,RHQ4,RX4, SX4, TX4, VX4
			1	-	-	-	2541696 ----- HX,QX,QXG,QXS, TX
			-	-	1	-	2533058
18	16582-883-300	HOLDER, CONTROL CABLE .....	1	-	-	-	----- QB26
			-	(1)	-	-	
19	16598-ZE0-000	STAY, CHOKE CONTROL .....	-	(1)	-	-	----- U1
			-	(1)	-	-	2377547 ----- H1,L1,Q1,R1,S1,V1,W1
	16598-ZE1-000	.....	1	-	-	-	----- QB26
			-	(1)	-	-	2377548 ----- H1,L1,Q1,R1,S1,V1,W1
20	16610-ZB2-000	LEVER COMP., CHOKE .....	1	-	-	-	----- VMT,VPR4
	16610-ZE1-000	LEVER COMP., CHOKE (STD.) ...	1	-	-	-	----- DS,EN,ET,ETX,HH,HHQ4,HTF2,HT2,HX,HXQ,HXU,HX2,HX26,HX4,LAJ4 LEH4,LH,LHQ4,LJ,LJC,LJD2,LJS,LJT,LSJ,LTA,LTJ,LTK1,LTR,LTS,LX LXU,LX2,LX26,LX4,PH,PX,PX2,QA,QAA2,QA2,QA26,QBU2,QEH,QH,QHQ4 QH2,QH26,QJG2,QJW1,QLL,QMA4,QMA8,QME4,QMH,QMX2,QPU,QSJ,QT,QTC2 QWA4,QX,QXC,QXC9,QXG,QXG2,QXQ,QXS,QXS2,QXU,QX2,QX26,QX4,QX7,RH RHC,RHQ4,RX,RX4,SAD2,SAJ,SAJ4,SCJ,SG24,SH,SHQ4,SJ,SJC,SJC1 SJC5,SJD2,SKJ,SKR,SMA7,SMJ,SMW2,SM11,SM12,SM14,SN,SSK1,SSK2 SSK3,SSX2,SSX4,STP,STS,SWX2,SWX4,SX,SXS4, SX4, SX7, TH, TX, TX2 TX26, TX4, UH, UX, UXU, VA, VAX4, VED, VED1, VED6, VEE1, VEK, VET, VEX, VEX7 VH, VMS4, VS, VSX, VSX1, VS1, VX, VXU, VX4, VX7, WDA6, WDJ, WD12, WJ, WJP WJP1, WJ1, WKD6, WKT2, WKT4, WKT6, WME2
			-	(1)	1	1	
21	16610-ZE1-810	LEVER COMP., CHOKE (REMOTE) ..	1	-	-	-	----- QB26
			-	(1)	-	-	
22	16615-ZE1-010	SPRING, RETURN .....	1	-	-	-	----- QA
			-	(1)	-	-	
23	16617-890-010	HOLDER, CABLE .....	1	-	-	-	----- QB26
			-	(1)	-	-	
24	16953-ZE1-812	LEVER, COCK .....	1	-	-	-	----- DS,EN,ET,ETX,HH,HHQ4,HTF2,HT2,HX,HXQ,HXU,HX2,HX26,HX4,LAJ4 LEH4,LH,LHQ4,LJ,LJC,LJD2,LJS,LJT,LSJ,LTA,LTJ,LTK1,LTR,LTS,LX LXU,LX2,LX26,LX4,PH,PX,PX2,QA,QAA2,QA2,QA26,QBU2,QB26,QEH,QH QHQ4,QH2,QH26,QJG2,QJW1,QLL,QMA4,QMA8,QME4,QMH,QMX2,QPU,QSJ,QT QTC2,QWA4,QX,QXC,QXC9,QXG,QXG2,QXQ,QXS,QXS2,QXU,QX2,QX26,QX4 QX7,RH,RHC,RHQ4,RX,RX4,SAD2,SAJ,SAJ4,SCJ,SG24,SH,SHQ4,SJ,SJC SJC1,SJC5,SJD2,SKJ,SKR,SMA7,SMJ,SMW2,SM11,SM12,SM14,SN,SSK1 SSK2,SSK3,SSX2,SSX4,STP,STS,SWX2,SWX4,SX,SXS4, SX4, SX7, TH, TX TX2, TX26, TX4, UH, UX, UXU, VA, VAX4, VED, VED1, VED6, VEE1, VEK, VET, VEX VEX7, VH, VMS4, VS, VSX, VSX1, VS1, VX, VXU, VX4, VX7, WDA6, WDJ, WD12, WJ WJP, WJP1, WJ1, WKD6, WKT2, WKT4, WKT6, WME2
			-	(1)	1	1	



E-14-1

CARBURETOR(2)

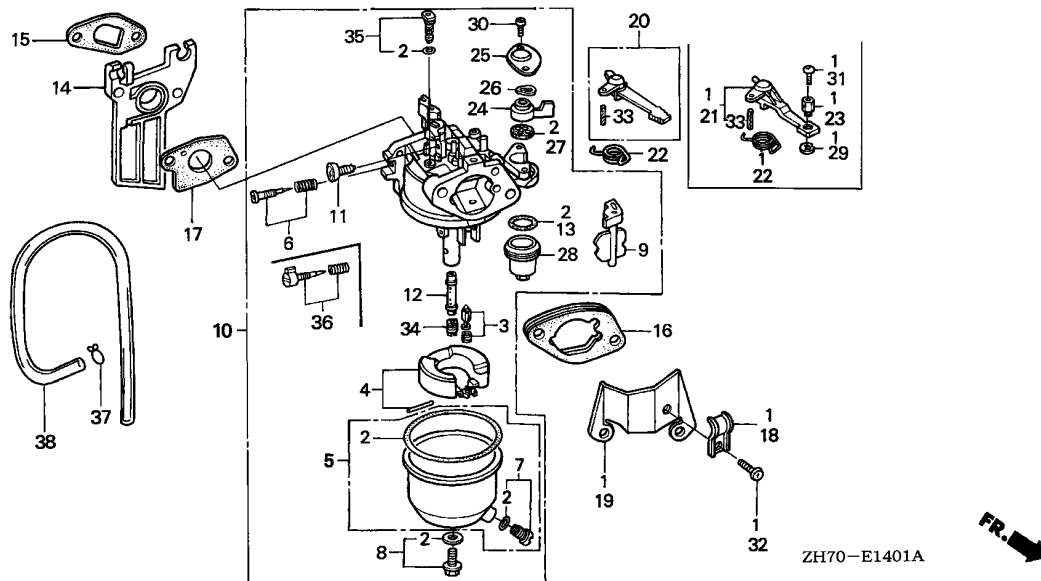

2

Ref. No.	Part No.	Description	Reqd. QTY				Serial No.	Parts catalogue code
			(1)	(2)	(3)	(4)		
25	16954-ZE1-811	PLATE, LEVER SETTING (CARBURETOR NO.)	1	-	-	-	BE12A B DS, LJ, LTA, LTJ, SAJ, SCJ, SJ, SJC, SKJ, SMJ, SSK1, SSK3, STP, STS, VET, WDJ WJ, WJP	
	///	///	1	-	-	-	BE60B A HTF2, HX2, LX2, PX2, QAA2, QH2, QMX2, QXG2, QXS2, QX2, SMW2, SSK2, TX2	
	///	///	1	-	-	-	BE60C A QA2, WKT2	
	16954-ZE1-812	.....	1	(1)	-	-	U1	
		(CARBURETOR NO.)	1	-	-	-	EN, ET, ETX, HH, HHQ4, HT2, HX, HXU, HX26, HX4, LAJ4, LEH4, LH, LHQ4, LJC LJD2, LJS, LJT, LSJ, LTK1, LTR, LTS, LX, LXU, LX26, LX4, PH, PX, QA, QA26 QBU2, QB26, QEH, QH, QHQ4, QH26, QJG2, QJW1, QLL, QMA4, QMA8, QME4, QMH QPU, QSJ, QT, QTC2, QWA4, QX, QXC, QXG, QXS, QXU, QX26, QX4, QX7, RH, RHC RHQ4, RX, RX4, SAD2, SAJ4, SG24, SH, SHQ4, SJC1, SJC5, SJD2, SKR, SMA7 SM11, SM12, SM14, SN, SSS2, SSS4, SWX2, SWX4, SX, SXS4, SX4, SX7, TH, TX TX26, TX4, UH, UX, UXU, VA, VAX4, VED, VED1, VED6, VEE1, VEK, VEX, VEX7, VH VMS4, VS, VSX, VSX1, VS1, VX, VXU, VX4, VX7, WDA6, WD12, WJP1, WJ1, WKD6 WKT4, WKT6, WME2	
	///	///	1	-	-	-	BE12A C ----- DS, LJ, LTA, LTJ, SAJ, SCJ, SJ, SJC, SKJ, SMJ, SSK1, SSK3, STP, STS, VET, WDJ WJ, WJP	
	///	///	1	-	-	-	BE60A B ----- HXQ, QXQ	
	///	///	1	-	-	-	BE60B B ----- HTF2, HX2, LX2, PX2, QAA2, QH2, QMX2, QXG2, QXS2, QX2, SMW2, SSK2, TX2	
	///	///	1	-	-	-	BE60C B ----- QA2, WKT2	
	///	///	1	-	-	-	BE60F B ----- QXC9	
	16954-ZF0-841	.....	-	(1)	1	1		
		(CARBURETOR NO.)	1	-	-	-	BE60A A HXQ, QXQ	
	///	///	1	-	-	-	BE60F A QXC9	

Ref. No.	Part No.	Description	Reqd. QTY				Serial No.	Parts catalogue code
			(1)	GX120K1 (2)	(3)	(4)		
26	16956-ZE1-811	SPRING, COCK LEVER .....	1	-	-	-	DS,EN,ET,ETX,HH,HHQ4,HTF2,HT2,HX,HXQ,HXU,HX2,HX26,HX4,LAJ4,LEH4,LH,LHQ4,LJ,LJC,LJD2,LJS,LJT,LSJ,LTA,LTJ,LTK1,LTR,LTS,LX,LXU,LX2,LX26,LX4,PH,PX,PX2,QA,QAA2,QA2,QA26,QBU2,QB26,QUEH,QHQ4,QH2,QH26,QJG2,QJW1,QLL,QMA4,QMA8,QME4,QMH,QMX2,QPU,QSJ,QT,QTC2,QWA4,QX,QXC,QXC9,QXG,QXG2,QXQ,QXS,QXS2,QXU,QX2,QX26,QX4,QX7,RH,RHC,RHQ4,RX,RX4,SAD2,SAJ,SAJ4,SCJ,SG24,SH,SHQ4,SJ,SJC,SJC1,SJC5,SJD2,SKJ,SKR,SMA7,SMJ,SMW2,SM11,SM12,SM14,SN,SSK1,SSK2,SSK3,SSX2,SSX4,STP,STS,SWX2,SWX4,SX,SXS4,SX4,SX7,TH,TX,TX2,TX26,TX4,UH,UX,UXU,VA,VAX4,VED,VED1,VED6,VEE1,VEK,VET,VEX,VEX7,VH,VMS4,VS,VSX,VSX1,VS1,VX,VXU,VX4,VX7,WDA6,WDJ,WD12,WJ,WJP,WJP1,WJ1,WKD6,WKT2,WKT4,WKT6,WME2	
			-	(1)	1	1		
27	16957-ZE1-812	PACKING, FUEL COCK .....	1	-	-	-	DS,EN,ET,ETX,HH,HHQ4,HTF2,HT2,HX,HXQ,HXU,HX2,HX26,HX4,LAJ4,LEH4,LH,LHQ4,LJ,LJC,LJD2,LJS,LJT,LSJ,LTA,LTJ,LTK1,LTR,LTS,LX,LXU,LX2,LX26,LX4,PH,PX,PX2,QA,QAA2,QA2,QA26,QBU2,QB26,QUEH,QHQ4,QH2,QH26,QJG2,QJW1,QLL,QMA4,QMA8,QME4,QMH,QMX2,QPU,QSJ,QT,QTC2,QWA4,QX,QXC,QXC9,QXG,QXG2,QXQ,QXS,QXS2,QXU,QX2,QX26,QX4,QX7,RH,RHC,RHQ4,RX,RX4,SAD2,SAJ,SAJ4,SCJ,SG24,SH,SHQ4,SJ,SJC,SJC1,SJC5,SJD2,SKJ,SKR,SMA7,SMJ,SMW2,SM11,SM12,SM14,SN,SSK1,SSK2,SSK3,SSX2,SSX4,STP,STS,SWX2,SWX4,SX,SXS4,SX4,SX7,TH,TX,TX2,TX26,TX4,UH,UX,UXU,VA,VAX4,VED,VED1,VED6,VEE1,VEK,VET,VEX,VEX7,VH,VMS4,VS,VSX,VSX1,VS1,VX,VXU,VX4,VX7,WDA6,WDJ,WD12,WJ,WJP,WJP1,WJ1,WKD6,WKT2,WKT4,WKT6,WME2	
			-	(1)	1	1		
28	16967-ZE0-811	CUP, FUEL STRAINER .....	1	-	-	-	DS,EN,ET,ETX,HH,HHQ4,HTF2,HT2,HX,HXQ,HXU,HX2,HX26,HX4,LAJ4,LEH4,LH,LHQ4,LJ,LJC,LJD2,LJS,LJT,LSJ,LTA,LTJ,LTK1,LTR,LTS,LX,LXU,LX2,LX26,LX4,PH,PX,PX2,QA,QAA2,QA2,QA26,QBU2,QB26,QUEH,QHQ4,QH2,QH26,QJG2,QJW1,QLL,QMA4,QMA8,QME4,QMH,QMX2,QPU,QSJ,QT,QTC2,QWA4,QX,QXC,QXC9,QXG,QXG2,QXQ,QXS,QXS2,QXU,QX2,QX26,QX4,QX7,RH,RHC,RHQ4,RX,RX4,SAD2,SAJ,SAJ4,SCJ,SG24,SH,SHQ4,SJ,SJC,SJC1,SJC5,SJD2,SKJ,SKR,SMA7,SMJ,SMW2,SM11,SM12,SM14,SN,SSK1,SSK2,SSK3,SSX2,SSX4,STP,STS,SWX2,SWX4,SX,SXS4,SX4,SX7,TH,TX,TX2,TX26,TX4,UH,UX,UXU,VA,VAX4,VED,VED1,VED6,VEE1,VEK,VET,VEX,VEX7,VH,VMS4,VS,VSX,VSX1,VS1,VX,VXU,VX4,VX7,WDA6,WDJ,WD12,WJ,WJP,WJP1,WJ1,WKD6,WKT2,WKT4,WKT6,WME2	
			-	(1)	1	1		
29	90605-230-000	CIRCLIP, 5MM .....	1	-	-	-	QB26	
			-	(1)	-	-		
30	93500-03008-1G	SCREW, PAN, 3X8 .....	2	(2)	2	-	UIH,U1,VAX4	
		(CARBURETOR NO.)	2	(2)	-	-	BE12C A H1,L1,QA,Q1,R1,S1,V1,W1	
		//	2	-	-	-	BE12A A HX,QX,QXG,QXS,TX	
		//	2	-	-	-	BE12A B DS,EN,ET,ETX,HH,HHQ4,HX4,LH,LHQ4,LJ,LTJ,LX,LX4,PH,PX,QUEH,QHQ4,QLL,QMA4,QMA8,QME4,QPU,QT,QX4,RH,RHC,RHQ4,RX,RX4,SAJ,SCJ,SH,SHQ4,SJ,SJC,SKJ,SMA7,SMJ,SN,SSK1,SSK3,SSX4,STP,SX,SX4,TH,TX4,UH,UX,VA,VED,VED1,VET,VEX,VH,VS,VSX,VSX1,VS1,VX,VX4,VX7,WDA6,WDJ,WJ,WJP	
		//	2	-	-	-	BE12K A LTA	
		//	2	-	-	-	BE13A A QXC,STS	
		//	2	-	-	-	BE60A A HXQ,QXQ	
		//	2	-	-	-	BE60B A HTF2,HX2,HX26,LX2,LX26,PX2,QAA2,QBU2,QH2,QH26,QMX2,QTC2,QXG2,QXS2,QX2,QX26,SAD2,SG24,SMW2,SSK2,TX2,TX26	
		//	2	-	-	-	BE60C A QA2,QA26,WKT2,WME2	
		//	2	-	-	-	BE60F A QXC9	
			-	-	-	2		



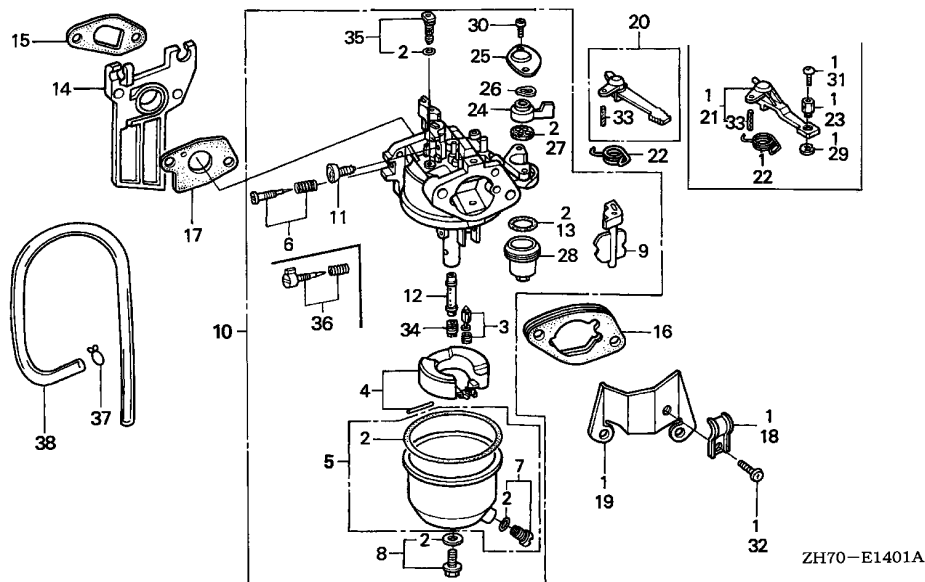

Ref. No.	Part No.	Description	Reqd. QTY				Serial No.	Parts catalogue code
			(1)	(2)	(3)	(4)		
30)	93500-03006-1H	SCREW, PAN, 3X6	2	-	2	-	HT2, HXU, LAJ4, LEH4, LJC, LJD2, LJS, LJT, LSJ, LTK1, LTS, LXU, QA, QB26, QIH1, QJG2, QJW1, QMH, QSJ, QWA4, QXU, QX7, SAJ4, SJC1, SJC5, SJD2, SKR, SM11, SM12, SM14, SSS2, SWX2, SWX4, SXS4, SX7, UXU, VED6, VEE1, VEK, VEX7, VMS4, VXU, VX7, WDA6, WD12, WIH1, WJ1, WKD6, WKT4, WKT6	
		(CARBURETOR NO.)	2	-	2	-	BE12A C ----- DS, EN, ET, ETX, HH, HHQ4, HX4, LH, LHQ4, LJ, LTJ, LX, LX4, PH, PX, QEH, QH, QHQ4, QLL, QMA4, QMA8, QME4, QPU, QT, QX4, RH, RHC, RHQ4, RX, RX4, SAJ, SCJ, SH, SHQ4, SJ, SJC, SKJ, SMA7, SMJ, SN, SSK1, SSK3, SSS4, STP, SX, SX4, TH, TX4, UH, UIH, UX, VA, VED, VED1, VET, VEX, VH, VS, VSX, VSX1, VS1, VX, VX4, WDJ, WJ, WJP	
	///		2	-	-	-	BE12A B ----- HX, QX, QXG, QXS, TX	
	///		2	-	-	-	BE12K B ----- LTA	
	///		2	-	-	-	BE13A B ----- QXC, STS	
	///		2	-	-	-	BE60A B ----- HXQ, QXQ	
	///		2	-	-	-	BE60B B ----- HTF2, HX2, HX26, LX2, LX26, PX2, QAA2, QBU2, QH2, QH26, QMX2, QTC2, QXG2, QXS2, QX2, QX26, SAD2, SG24, SMW2, SSK2, TX2, TX26	
	///		2	-	-	-	BE60C B ----- QA2, QA26, WKT2, WME2	
	///		2	-	-	-	BE60F B ----- QXC9	
	///		-	(2)	-	-	BE12C B ----- H1, L1, Q1, R1, S1, V1, W1	
	///		-	-	-	2	BE12A C	
31	93500-04008-0A	SCREW, PAN, 4X8	1	-	-	-	QB26	
			-	(1)	-	-		
32	93500-05008-0A	SCREW, PAN, 5X8	1	-	-	-	QB26	
			-	(1)	-	-		

Ref. No.	Part No.	Description	Reqd. QTY				Serial No.	Parts catalogue code
			(1)	GX120K1 (2)	(3)	(4)		
33	94305-20122	PIN, SPRING, 2X12 .....	1	-	-	-	-----	DS,EN,ET,ETX,HH,HHQ4,HTF2,HT2,HX,HXQ,HXU,HX2,HX26,HX4,LAJ4,LEH4,LH,LHQ4,LJ,LJC,LJD2,LJS,LJT,LSJ,LTA,LTJ,LTK1,LTR,LTS,LX,LXU,LX2,LX26,LX4,PH,PX,PX2,QA,QAA2,QA2,QA26,QBU2,QB26,QUEH,QH,QHQ4,QH2,QH26,QJG2,QJW1,QLL,QMA4,QMA8,QME4,QMH,QMX2,QPU,QSJ,QT,QT C2,QWA4,QX,QXC,QXC9,QXG,QXG2,QXQ,QXS,QXS2,QXU,QX2,QX26,QX4,QX7,RH,RHC,RHQ4,RX,RX4,SAD2,SAJ,SAJ4,SCJ,SG24,SH,SHQ4,SJ,SJC,SJC1,SJC5,SJD2,SKJ,SKR,SMA7,SMJ,SMW2,SM11,SM12,SM14,SN,SSK1,SSK2,SSK3,SSX2,SSX4,STP,STS,SWX2,SWX4,SX,SXS4,SX4,SX7,TH,TX,TX2,TX26,TX4,UH,UX,UXU,VA,VAX4,VED,VED1,VED6,VEE1,VEK,VET,VEX,VEX7,VH,VMS4,VMT,VPR4,VS,VSX,VSX1,VS1,VX,VXU,VX4,VX7,WDA6,WDJ,WD12,WJ,WJP,WJP1,WJ1,WKD6,WKT2,WKT4,WKT6,WME2
			-	(1)	1	1		
34	99101-ZF5-0550	JET, MAIN, #55 .....	(1)	-	(1)	-	-----	HH,QXG,QXS,RH,VA,VH,VS1,WIH1
		(CARBURETOR NO.)	(1)	-	(1)	-	-----	BE12A A EN,ET,ETX,QT,SN,UIH,VED,VED1
			-	(1)	-	-		
	99101-ZF5-0580	JET, MAIN, #58 .....	(1)	-	(1)	-	-----	HH,QXG,QXS,RH,VA,VH,VS1,WIH1
		(CARBURETOR NO.)	(1)	-	(1)	-	-----	BE12A A EN,ET,ETX,QT,SN,UIH,VED,VED1
			-	(1)	-	-		
	99101-ZF5-0600	JET, MAIN, #60 .....	1	-	1	-	-----	BE12A A EN,ET,ETX,HH,HX,LH,LX,PH,PX,QUEH,QH,QPU,QT,QX,QXG,QXS,RH,RHC,RX,SH,SN,SX,TH,TX,UH,UH,UX,VA,VED,VED1,VEX,VH,VS,VSX,VSX1,VS1,VX
		(CARBURETOR NO.)	-	1	-	1	-----	BE12A A
	99101-ZF5-0620	JET, MAIN, #62 .....	(1)	-	-	-	-----	VH
			-	(1)	-	-		
	99101-ZH7-0650	JET, MAIN, #65 .....	(1)	-	-	-	-----	BE60M A QB26
		(CARBURETOR NO.)	(1)	-	-	-	-----	BE60M A QB26
	99101-ZH7-0680	JET, MAIN, #68 .....	1	-	-	-	-----	QAA2,QBU2,SAD2,SSK2
		(CARBURETOR NO.)	(1)	-	-	-	-----	BE12A B BE12A C EN,ET,ETX
	99101-ZH7-0550	JET, MAIN, #55 .....	(1)	-	-	-	-----	HXQ,QAA2,QBU2,QS,JS,QXQ,SAD2,SSK2
		(CARBURETOR NO.)	(1)	-	-	-	-----	BE12A B BE12A C EN,ET,ETX
	99101-ZH7-0580	JET, MAIN, #58 .....	(1)	-	-	-	-----	HH,QXG,QXS,RH,U1,VA,VH,VS1,V1
		(CARBURETOR NO.)	1	1	-	-	-----	BE12A B BE12A C EN,ET,ETX,QT,SN,UIH,VED,VED1
		''	1	-	-	-	-----	QAA2,QBU2,SAD2,SSK2
		(CARBURETOR NO.)	1	-	-	-	-----	BE12A C QME4
			(1)	(1)	-	-	-----	HXQ,H1,QS,JS,QXQ,Q1,R1,W1
	99101-ZH7-0620	JET, MAIN, #62 .....	1	-	-	-	-----	HXQ,QS,JS,QXQ
		(CARBURETOR NO.)	(1)	-	-	-	-----	BE60M A QB26
	99101-ZH8-0550	JET, MAIN, #55 .....	(1)	-	-	-	-----	HHQ4,HTF2,HT2,HX,HXU,HX2,HX26,HX4,LAJ4,LEH4,LH,LHQ4,LJD2,LJT,LX,LXU,LX2,LX26,LX4,PH,PX,PX2,QA,QUEH,QH,QHQ4,QH2,QH26,QJG2,QJW1,QLL,QMA4,QMA8,QMH,QMX2,QPU,QT C2,QWA4,QX,QXG2,QXS2,QXU,QX2,QX26,QX4,QX7,RHC,RHQ4,RX,RX4,SAJ4,SG24,SH,SHQ4,SJD2,SMA7,SMJ,SMW2,SM11,SM12,SM14,SSK1,SSK3,SSX2,SSX4,STP,SWX2,SWX4,SX,SXS4,SX4,SX7,TH,TX,TX2,TX26,TX4,UH,UX,UXU,VAX4,VEE1,VEK,VEX,VEX7,VMS4,VS,VSX,VSX1,VX,VXU,VX4,VX7,WDA6
		(CARBURETOR NO.)	(1)	-	-	-	-----	BE12A C BE12A C EN,ET,ETX
		''	(1)	-	-	-	-----	BE60B B BE60B B QB26
			-	(1)	-	(1)		





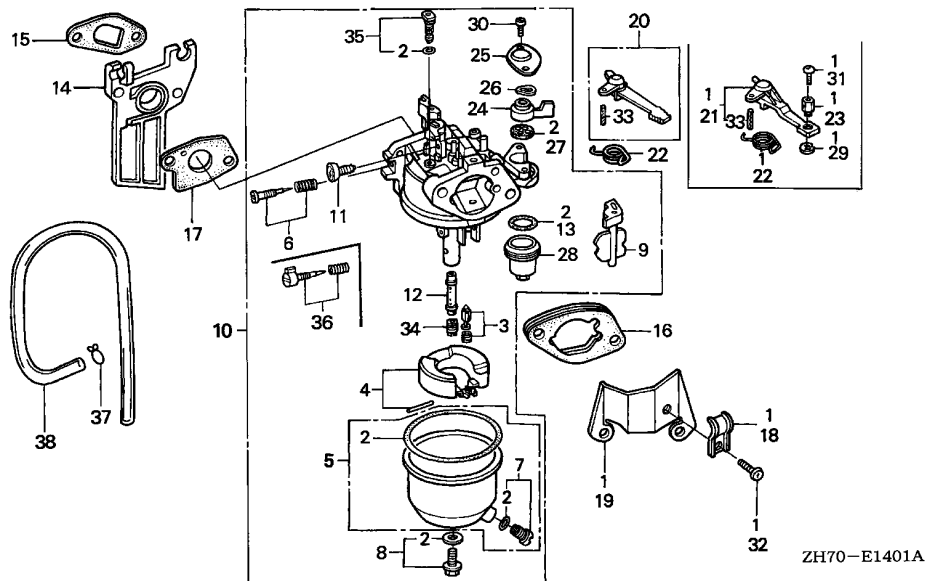

Ref. No.	Part No.	Description	Reqd. QTY				Serial No.	Parts catalogue code
			(1)	(2)	(3)	(4)		
			GX120K1					
34)	99101-ZH8-0580	JET, MAIN, #58 .....	(1)	-	(1)	-	-----	DS,HHQ4,HTF2,HT2,HX,HXU,HX2,HX26,HX4,LAJ4,LEH4,LH,LHQ4,LJ,LJC LJD2,LJS,LJT,LSJ,LTK1,LTR,LX,LXU,LX2,LX26,LX4,PH,PX,PX2,QA,QA2 QA26,QEH,QH,QHQ4,QH2,QH26,QIH1,QJG2,QJW1,QLL,QMA4,QMA8,QME4 QMH,QMX2,QPU,QSJ,QT2,QWA4,QX,QXC,QXC9,QXG2,QXS2,QXU,QX2,QX26 QX4,QX7,RHC,RHQ4,RX,RX4,SAJ,SAJ4,SCJ,SG24,SH,SHQ4,SJ,SJC,SJC1 SJC5,SJD2,SKJ,SKR,SMA7,SMJ,SMW2,SM11,SM12,SM14,SSK1,SSK3,SSX2 SSX4,STP,STS,SWX2,SWX4,SX,SXS4,SX4,SX7,TH,TX,TX2,TX26,TX4,UH UX,UXU,VAX4,VED6,VEE1,VEK,VET,VEX,VEX7,VMS4,VMT,VPR4,VS,VSX VSX1,VX,VXU,VX4,VX7,WDA6,WDJ,WD12,WIH1,WJ,WJP,WJP1,WJ1,WKD6 WKT2,WKT4,WKT6,WME2 QT,SN,UIH,VED,VED1
		(CARBURETOR NO.)	(1)	-	(1)	-	BE12A B -----	QT,SN,UIH,VED,VED1
		///	(1)	-	-	-	BE12A C -----	EN,ET,ETX
		///	(1)	-	-	-	BE60C B LTJ	
		///	(1)	-	-	-	BE60B B BE60B B QB26	
			-	(1)	-	(1)		

Ref. No.	Part No.	Description	Reqd. QTY				Serial No.	Parts catalogue code
			(1)	(2)	(3)	(4)		
34)	99101-ZH8-0600	JET, MAIN, #60 (CARBURETOR NO.)	1	-	(1)	-	BE12A B	HX, LH, LX, PH, PX, QEH, QH, QPU, QX, RHC, RX, SH, SX, TH, TX, UH, UIH, UX, VEX VS, VSX, VSX1, VX
			1	-	-	-		HHQ4, HTF2, HT2, HXU, HX2, HX26, HX4, LAJ4, LEH4, LHQ4, LJD2, LJT, LXU, LX2 LX26, LX4, PX2, QA, QHQ4, QH2, QH26, QJG2, QJW1, QLL, QMA4, QMA8, QMH, QMX2 QTC2, QWA4, QXG2, QXS2, QXU, QX2, QX26, QX4, QX7, RHQ4, RX4, SAJ4, SG24 SHQ4, SJD2, SMA7, SMJ, SMW2, SM11, SM12, SM14, SSK1, SSK3, SSS2, SSS4, STP SWX2, SWX4, SXS4, SX4, SX7, TX2, TX26, TX4, UXU, VAX4, VEE1, VEK, VEX7 VMS4, VXU, VX4, VX7, WDA6
		(CARBURETOR NO.)	1	-	-	-	BE60B B	QB26
			(1)	-	(1)	-		DS, LJ, LJC, LJS, LSJ, LTA, LTK1, LTR, QA2, QA26, QIH1, QME4, QSJ, QXC, QXC9 SAJ, SCJ, SJ, SJC, SJC1, SJC5, SKJ, SKR, STS, VED6, VET, VMT, VPR4, WDJ WD12, WIH1, WJ, WJP, WJP1, WJ1, WKD6, WKT2, WKT4, WKT6, WME2
		(CARBURETOR NO.)	(1)	-	-	-	BE12A B	QT, SN, VED, VED1
		//	(1)	-	-	-	BE60L A	EN, ET, ETX
		//	(1)	-	-	-	BE60C B	LTJ
		(CARBURETOR NO.)	-	1	-	-	BE12A B	
	99101-ZH8-0620	JET, MAIN, #62	1	-	-	-		WD12, WME2
	99101-ZH8-0600	JET, MAIN, #60 (CARBURETOR NO.)	1	-	-	-	BE12A C	BE12A C EN, ET, ETX
	99101-ZH8-0620	JET, MAIN, #62	1	-	1	-		DS, LJ, LJC, LJS, LSJ, LTK1, LTR, QA2, QA26, QIH1, QSJ, QXC, QXC9, SAJ, SCJ SJ, SJC, SJC1, SJC5, SKJ, SKR, STS, VED6, VET, VMT, VPR4, WDJ, WIH1, WJ, WJP WJP1, WJ1, WKD6, WKT2, WKT4, WKT6
		(CARBURETOR NO.)	1	-	1	-	BE60L A	EN, ET, ETX, QME4, QT, SN, UIH, VED, VED1
		//	1	-	-	-	BE60C B	LTJ
		(CARBURETOR NO.)	(1)	-	-	-		LTA
	99101-ZH8-0650	JET, MAIN, #65 (CARBURETOR NO.)	(1)	-	-	-	BE60M A	QB26
	99101-ZH8-0680	JET, MAIN, #68 (CARBURETOR NO.)	1	-	-	-	BE60M A	QB26
	99101-ZH8-0550	JET, MAIN, #55 (CARBURETOR NO.)	(1)	-	-	-		LTS
	99101-ZH8-0580	JET, MAIN, #58 (CARBURETOR NO.)	(1)	-	-	-	BE60B B	LTJ
	99101-ZH8-0600	JET, MAIN, #60 (CARBURETOR NO.)	(1)	-	-	-	BE60B B	LTJ
	99101-ZH8-0600	JET, MAIN, #60 (CARBURETOR NO.)	1	-	-	-		LTS, SJD2, VEK
		(CARBURETOR NO.)	1	-	-	-	BE60B B	LTJ
35	99204-ZE0-0350	JET SET, PILOT, #35	1	-	-	-		DS, EN, ET, ETX, HH, HHQ4, HTF2, HT2, HX, HXQ, HXU, HX2, HX26, HX4, LAJ4 LEH4, LH, LHQ4, LJ, LJC, LJD2, LJS, LJT, LSJ, LTA, LTJ, LTK1, LTR, LTS, LX LXU, LX2, LX26, LX4, PH, PX, PX2, QA, QAA2, QA2, QA26, QBU2, QB26, QEH, QH QHQ4, QH2, QH26, QJG2, QJW1, QLL, QMA4, QMA8, QME4, QMH, QMX2, QPU, QSJ, QT QT C2, QWA4, QX, QXG, QXG2, QXQ, QXS, QXS2, QXU, QX2, QX26, QX4, QX7, RH, RHC RHQ4, RX, RX4, SAD2, SAJ, SAJ4, SCJ, SG24, SH, SHQ4, SJ, SJC, SJC1, SJC5 SJD2, SKJ, SKR, SMA7, SMJ, SMW2, SM11, SM12, SM14, SN, SSK1, SSK2, SSK3 SSS2, SSS4, STP, STS, SWX2, SWX4, SX, SXS4, SX4, SX7, TH, TX, TX2, TX26, TX4 UH, UX, UXU, VA, VAX4, VED, VED1, VED6, VEE1, VEK, VET, VEX, VEX7, VH, VMS4 VMT, VPR4, VS, VSX, VSX1, VS1, VX, VXU, VX4, VX7, WDA6, WDJ, WD12, WJ, WJP WJP1, WJ1, WKD6, WKT2, WKT4, WKT6, WME2
		(CARBURETOR NO.)	1	-	-	-	BE13A B	QXC
	99204-ZE2-0380	JET SET, PILOT, #38 (CARBURETOR NO.)	1	-	(1)	1		QXC9
			1	-	-	-	BE60F B	QXC



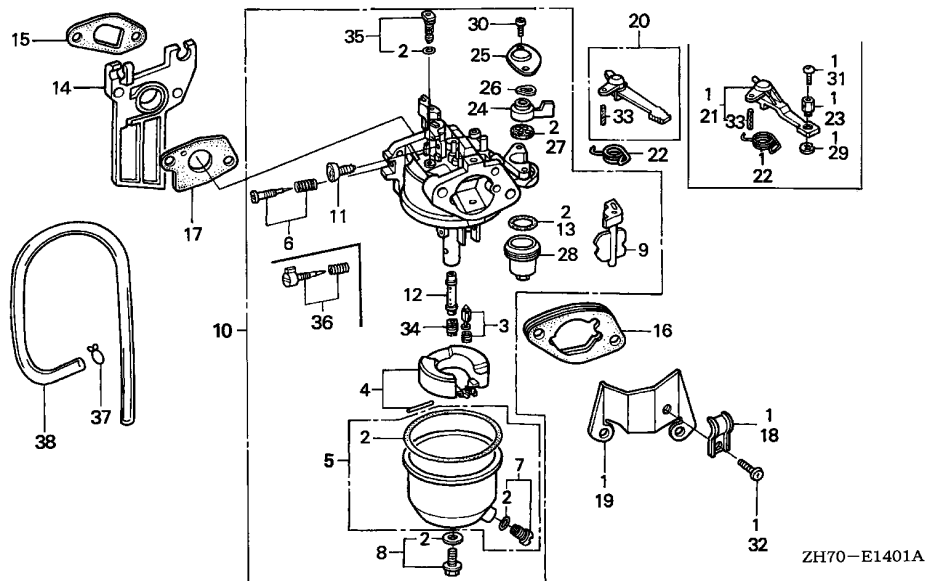

Ref. No.	Part No.	Description	Reqd. QTY				Serial No.	Parts catalogue code
			(1)	(2)	(3)	(4)		
36	16016-ZH7-W01	SCREW SET, PILOT .....	1	-	-	-	HTF2, HT2, HXQ, HX2, HX26, LJD2, LJS, LTS, LX2, LX26, PX2, QAA2, QA2, QA26, QBU2, QH2, QH26, QJG2, QMX2, QTC2, QWA4, QXC9, QXG2, QXQ, QXS2, QX2, QX26, QX7, SAD2, SG24, SJD2, SMW2, SM11, SM12, SM14, SSK2, SSX2, SWX2, SWX4, SXS4, SX7, TX2, TX26, VED6, VEX7, VX7, WDA6, WD12, WKD6, WKT2, WKT4, WKT6, WME2	
		(CARBURETOR NO.)	1	-	-	-	BE60B B ----- HHQ4, HX, HXU, HX4, LAJ4, LEH4, LH, LHQ4, LJT, LX, LXU, LX4, PH, PX, QEH, QH, QHQ4, QJW1, QMA4, QMA8, QMH, QPU, QX, QXU, QX4, RHQ4, RX, RX4, SAJ4, SH, SHQ4, SKR, SMA7, SMJ, SSK1, SSK3, SSX4, SX, SX4, TH, TX, TX4, UH, UX, UXU, VEE1, VEX, VMS4, VS, VX, VXU, VX4	
		//	1	-	-	-	BE60C B ----- DS, LJ, LSJ, LTJ, LTR, SAJ, SCJ, SJ, SJC, SJC1, SJC5, SKJ, VED, VED1, VET, WDJ, WJ, WJP, WJP1, WJ1	
		//	1	-	-	-	BE60F B ----- QXC	
		//	1	-	-	-	BE60B B BE60B B QB26	
37	95002-02080	CLIP, TUBE (B8) .....	1	-	-	-	LTA	
38	95003-09023-31	TUBE, VINYL, 4.5X8X230 (95003-09001-60M)	1	-	-	-	LTA	

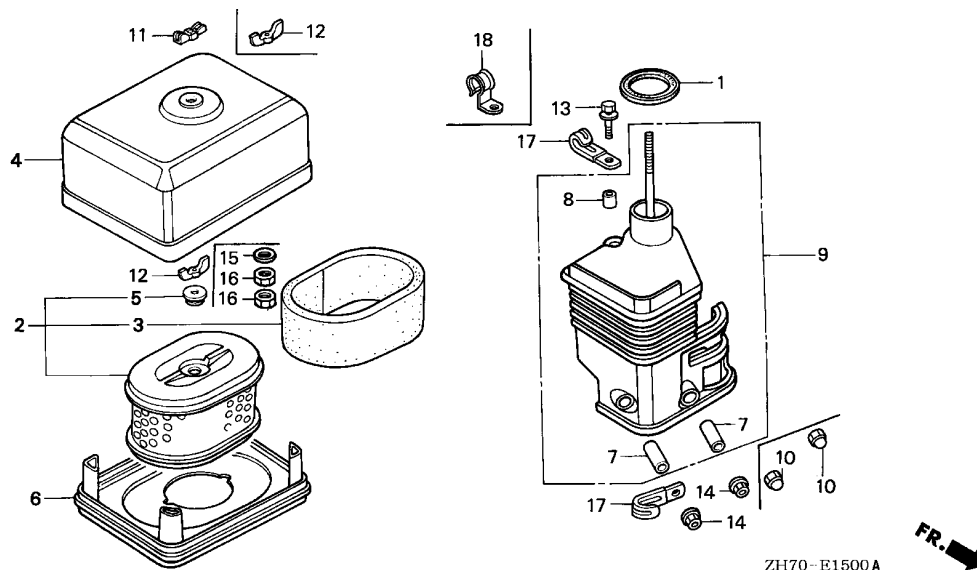

Ref. No.	L.O.N.	(Relative ref. Number) Description	F.R.T.
1	3121E1	PACKING, ELBOW .....	0.1
2	3121B8	ELEMENT, AIR CLEANER .....	0.1
3	3121C1	FILTER, OUTER .....	0.1
6	3121D6	NOSE, SILENCER .....	0.1
9	3121B4	ELBOW, AIR CLEANER .....	0.1

Ref. No.	Part No.	Description	Reqd. QTY				Serial No.	Parts catalogue code
			(1)	(2)	(3)	(4)		
1	16271-ZE1-000	PACKING, ELBOW .....	1	-	-	-	HH,HHQ4,HTF2,HT2,HX,HXQ,HXU,HX2,HX26,HX4,KRF4,KRS4,LAJ4,LE,LEH4,LH,LHQ4,LJD2,LJT,LTA,LTS,LX,LXU,LX2,LX26,LX4,PH,PX,PX2,QAA2,QBU2,QE,QEH,QH,QHQ4,QH2,QH26,QJG2,QJW1,QLL,QMA4,QMA8,QMX2,QPU,QTC2,QWA4,QX,QXG,QXG2,QXQ,QXS,QXS2,QXU,QX2,QX26,QX4,QX7,RH,RHC,RHQ4,RX,RX4,SAD2,SAJ4,SE,SG24,SH,SHQ4,SJD2,SMA7,SMJ,SMW2,SM11,SM12,SM14,SSK1,SSK2,SSK3,SSX2,SSX4,STP,SWX2,SWX4,SW2,SX,SXS4,SX4,SX7,TH,TX,TX2,TX26,TX4,UH,UX,UXU,VA,VAX4,VEK,VEX,VEX7,VH,VMS4,VS,VSX,VSX1,VS1,VX,VXU,VX4,VX7,WDA6	
			1	-	-	-	2965582	QMH
			1	-	-	-	3093871	VEE1
			1	-	-	-	3558049	LTJ
			1	-	-	-	3230227	3323432 QB26
			-	(1)	-	1		
2	17210-ZE0-822	ELEMENT, AIR CLEANER (DUAL) -	1	-	-	-	HH,HHQ4,HTF2,HT2,HX,HXQ,HXU,HX2,HX26,HX4,KRF4,KRS4,LAJ4,LE,LEH4,LH,LHQ4,LJD2,LJT,LTA,LTS,LX,LXU,LX2,LX26,LX4,PH,PX,PX2,QAA2,QBU2,QE,QEH,QH,QHQ4,QH2,QH26,QJG2,QJW1,QLL,QMA4,QMA8,QMX2,QPU,QTC2,QWA4,QX,QXG,QXG2,QXQ,QXS,QXS2,QXU,QX2,QX26,QX4,QX7,RH,RHC,RHQ4,RX,RX4,SAD2,SAJ4,SE,SG24,SH,SHQ4,SJD2,SMA7,SMJ,SMW2,SM11,SM12,SM14,SSK1,SSK2,SSK3,SSX2,SSX4,STP,SWX2,SWX4,SW2,SX,SXS4,SX4,SX7,TH,TX,TX2,TX26,TX4,UH,UX,UXU,VA,VAX4,VEK,VEX,VEX7,VH,VMS4,VS,VSX,VSX1,VS1,VX,VXU,VX4,VX7,WDA6	
			1	-	-	-	2965582	QMH
			1	-	-	-	3093871	VEE1
			1	-	-	-	3558049	LTJ
			1	-	-	-	3230227	3323432 QB26
			-	(1)	-	1		



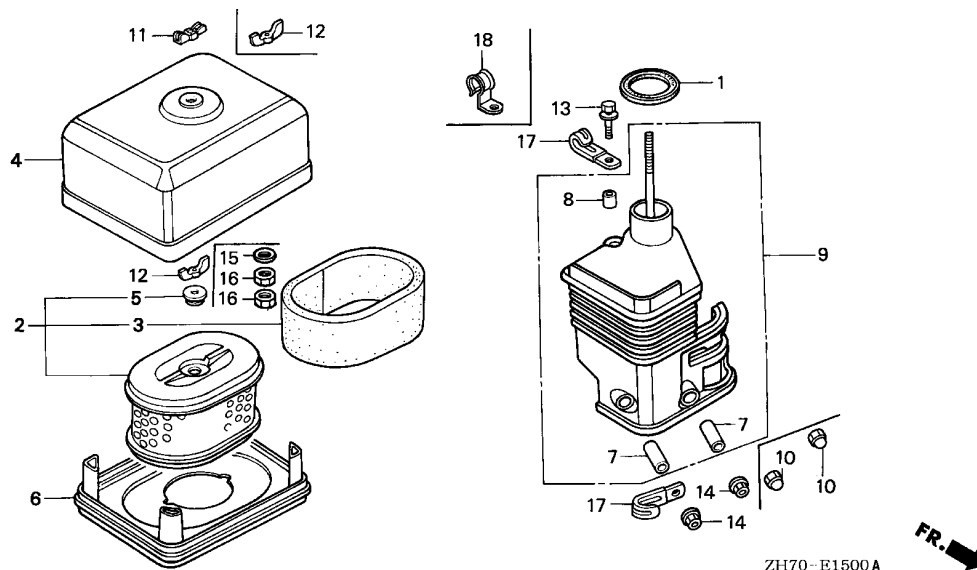

Ref. No.	Part No.	Description	Reqd. QTY				Serial No.	Parts catalogue code
			(1)	(2)	(3)	(4)		
3	17218-ZE0-821	FILTER, OUTER .....	1	-	-	-	HH,HHQ4,HTF2,HT2,HX,HXQ,HXU,HX2,HX26,HX4,KRF4,LAJ4,LE,LEH4,LH,LHQ4,LJD2,LJT,LTA,LTS,LX,LXU,LX2,LX26,LX4,PH,PX,PX2,QAA2,QBU2,QE,QEH,QH,QHQ4,QH2,QH26,QJG2,QJW1,QLL,QMA4,QMA8,QMX2,QPU,QTC2,QWA4,QX,QXG,QXG2,QXQ,QXS,QXS2,QXU,QX2,QX26,QX4,QX7,RH,RHC,RHQ4,RX,RX4,SAD2,SAJ4,SE,SG24,SH,SHQ4,SJD2,SMA7,SMJ,SMW2,SM11,SM12,SM14,SSK1,SSK2,SSK3,SSX2,SSX4,STP,SWX2,SWX4,SW2,SX,SXS4,SX4,SX7,TH,TX,TX2,TX26,TX4,UH,UX,UXU,VA,VAX4,VEK,VEX,VEX7,VH,VMS4,VS,VSX,VSX1,VS1,VX,VXU,VX4,VX7,WDA6	
			1	-	-	-	2965582	QMH
			1	-	-	-	3093871	VEE1
			1	-	-	-	3558049	LTJ
			1	-	-	-	3230227	3323432 QB26
			-	(1)	-	1		
	17218-ZE1-821	.....	1	-	-	-		KRS4
4	17230-ZE0-820	COVER, AIR CLEANER (DUAL) ...	1	-	-	-	HH,HHQ4,HTF2,HT2,HX,HXQ,HXU,HX2,HX26,HX4,KRF4,LAJ4,LE,LEH4,LH,LHQ4,LJD2,LJT,LTA,LTS,LX,LXU,LX2,LX26,LX4,PH,PX,PX2,QAA2,QBU2,QE,QEH,QH,QHQ4,QH2,QH26,QJG2,QJW1,QLL,QMA4,QMA8,QMX2,QPU,QTC2,QWA4,QX,QXG,QXG2,QXQ,QXS,QXS2,QXU,QX2,QX26,QX4,QX7,RH,RHC,RHQ4,RX,RX4,SAD2,SAJ4,SE,SG24,SH,SHQ4,SJD2,SMA7,SMJ,SMW2,SM11,SM12,SM14,SSK1,SSK2,SSK3,SSX2,SSX4,STP,SWX2,SWX4,SW2,SX,SXS4,SX4,SX7,TH,TX,TX2,TX26,TX4,UH,UX,UXU,VA,VAX4,VEK,VEX,VEX7,VH,VMS4,VS,VSX,VSX1,VS1,VX,VXU,VX4,VX7,WDA6	
			1	-	-	-	2965582	QMH
			1	-	-	-	3093871	VEE1
			1	-	-	-	3230227	QB26
			1	-	-	-	3558049	LTJ
			-	(1)	-	1		
	17230-ZE1-820	.....	1	-	-	-		KRS4

Ref. No.	Part No.	Description	Reqd. QTY				Serial No.	Parts catalogue code
			(1)	GX120K1 (2)	(3)	(4)		
5	17232-891-000	GROMMET, AIR CLEANER .....	1	-	-	-	-----	HH,HHQ4,HTF2,HT2,HX,HXQ,HXU,HX2,HX26,HX4,KRF4,KRS4,LAJ4,LE LEH4,LH,LHQ4,LJD2,LJT,LTA,LTS,LX,LXU,LX2,LX26,LX4,PH,PX,PX2 QAA2,QBU2,QE,QEH,QH,QHQ4,QH2,QH26,QJG2,QJW1,QLL,QMA4,QMA8,QMX2 QPU,QTC2,QWA4,QX,QXG,QXG2,QXQ,QXS,QXS2,QXU,QX2,QX26,QX4,QX7,RH RHC,RHQ4,RX,RX4,SAD2,SAJ4,SE,SG24,SH,SHQ4,SJD2,SMA7,SMJ,SMW2 SM11,SM12,SM14,SSK1,SSK2,SSK3,SSX2,SSX4,STP,SWX2,SWX4,SW2,SX SXS4,SX4,SX7,TH,TX,TX2,TX26,TX4,UH,UX,UXU,VA,VAX4,VEK,VEX,VEX7 VH,VMS4,VS,VSX,VSX1,VS1,VX,VXU,VX4,VX7,WDA6
			1	-	-	-	2965582	----- QMH
			1	-	-	-	3093871	----- VEE1
			1	-	-	-	3558049	----- LTJ
			1	-	-	-	3230227	3323432 QB26
			-	(1)	-	1		
6	17235-ZE1-830	NOSE, SILENCER .....	1	-	-	-	-----	2535087 QMA8,SMA7
			1	-	-	-	-----	2538119 SSK1,SSK3
			1	-	-	-	-----	2555889 LE,QE,QLL,SE
			-	(1)	-	-	-----	H1,L1,R1,U1,V1,W1
			-	(1)	-	-	-----	2549774 Q1,S1
	17235-ZE1-831	.....	1	-	-	-	-----	KRS4,LJD2,QBU2,QTC2,QWA4,QX7,SAD2,SG24,SJD2,SM11,SM12,SM14 SSX2,SSX4,STP,SX7,VEK,VEX7,VMS4,VX7
			1	-	-	-	2535088	----- QMA8,SMA7
			1	-	-	-	2538120	----- SSK1,SSK3
			1	-	-	-	2555890	----- LE,QE,QLL,SE
			1	-	-	-	3093871	----- VEE1
			1	-	-	-	2622722	QMX2,SSK2
			-	(1)	-	-	2549775	----- Q1,S1
7	17238-ZE0-010	COLLAR, AIR CLEANER .....	2	-	-	-	-----	HH,HHQ4,HTF2,HT2,HX,HXQ,HXU,HX2,HX26,HX4,KRF4,LAJ4,LE,LEH4,LH LHQ4,LJD2,LJT,LTA,LTS,LX,LXU,LX2,LX26,LX4,PH,PX,PX2,QAA2,QBU2 QB26,QE,QEH,QH,QHQ4,QH2,QH26,QJG2,QJW1,QLL,QMA4,QMA8,QMX2,QPU QTC2,QWA4,QX,QXG,QXG2,QXQ,QXS,QXS2,QXU,QX2,QX26,QX4,QX7,RH,RHC RHQ4,RX,RX4,SAD2,SAJ4,SE,SG24,SH,SHQ4,SJD2,SMA7,SMJ,SMW2,SM11 SM12,SM14,SSK1,SSK2,SSK3,SSX2,SSX4,STP,SWX2,SWX4,SW2,SX,SXS4 SX4,SX7,TH,TX,TX2,TX26,TX4,UH,UX,UXU,VA,VAX4,VEK,VEX,VEX7,VH VMS4,VS,VSX,VSX1,VS1,VX,VXU,VX4,VX7,WDA6
			2	-	-	-	2965582	----- QMH
			2	-	-	-	3093871	----- VEE1
			2	-	-	-	3558049	----- LTJ
			-	(2)	-	2		
	17238-ZE7-010	.....	2	-	-	-	-----	KRS4
8	17239-ZE1-000	COLLAR B, AIR CLEANER .....	1	-	-	-	-----	HH,HHQ4,HTF2,HT2,HX,HXQ,HXU,HX2,HX26,HX4,KRF4,KRS4,LAJ4,LE LEH4,LH,LHQ4,LJD2,LJT,LTA,LTS,LX,LXU,LX2,LX26,LX4,PH,PX,PX2 QAA2,QBU2,QB26,QE,QEH,QH,QHQ4,QH2,QH26,QJG2,QJW1,QLL,QMA4,QMA8 QMX2,QPU,QTC2,QWA4,QX,QXG,QXG2,QXQ,QXS,QXS2,QXU,QX2,QX26,QX4 QX7,RH,RHC,RHQ4,RX,RX4,SAD2,SAJ4,SE,SG24,SH,SHQ4,SJD2,SMA7,SMJ SMW2,SM11,SM12,SM14,SSK1,SSK2,SSK3,SSX2,SSX4,STP,SWX2,SWX4,SW2 SX,SXS4,SX4,SX7,TH,TX,TX2,TX26,TX4,UH,UX,UXU,VA,VAX4,VEK,VEX VEX7,VH,VMS4,VS,VSX,VSX1,VS1,VX,VXU,VX4,VX7,WDA6
			1	-	-	-	2965582	----- QMH
			1	-	-	-	3093871	----- VEE1
			1	-	-	-	3558049	----- LTJ
			-	(1)	-	1		



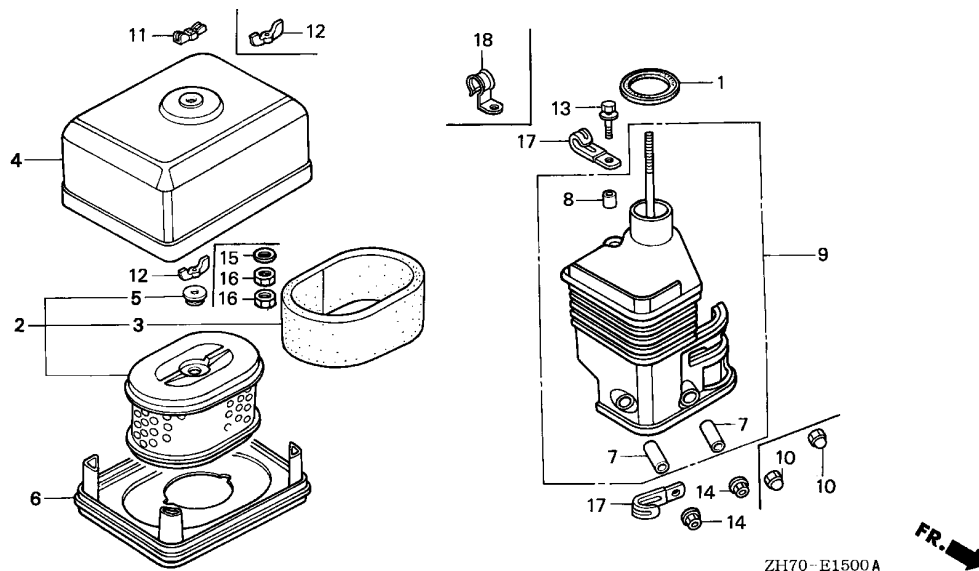

Ref. No.	Part No.	Description	Reqd. QTY				Serial No.	Parts catalogue code
			(1)	(2)	(3)	(4)		
9	17410-ZE0-030	ELBOW COMP., AIR CLEANER	1	-	-	-	HH,HHQ4,HTF2,HT2,HX,HXQ,HXU,HX2,HX26,HX4,KRF4,LAJ4,LE,LEH4,LH,LHQ4,LJD2,LJT,LTA,LTS,LX,LXU,LX2,LX26,LX4,PH,PX,PX2,QAA2,QBU2,QB26,QE,QEH,QH,QHQ4,QH2,QH26,QJG2,QJW1,QLL,QMA4,QMA8,QMX2,QPU,QTC2,QWA4,QX,QXG,QXG2,QXQ,QXS,QXS2,QXU,QX2,QX26,QX4,QX7,RH,RHC,RHQ4,RX,RX4,SAD2,SAJ4,SE,SG24,SH,SHQ4,SJD2,SMA7,SMJ,SMW2,SM11,SM12,SM14,SSK1,SSK2,SSK3,SSX2,SSX4,STP,SWX2,SWX4,SW2,SX,SXS4,SX4,SX7,TH,TX,TX2,TX26,TX4,UH,UX,UXU,VA,VAX4,VEK,VEX,VEX7,VH,VMS4,VS,VSX,VSX1,VS1,VX,VXU,VX4,VX7,WDA6	
			1	-	-	-	2965582	QMH
			1	-	-	-	3093871	VEE1
			1	-	-	-	3558049	LTJ
	17410-ZE1-020	.....	-	(1)	-	1		
10	90201-415-000	NUT, CAP, 6MM	1	-	-	-	KRS4	
			2	-	-	-	2299856	HH,HX,HXQ,HX2,LE,LH,LTA,LX,LX2,PH,PX,QE,QEH,QH,QH2,QX,QXG,QXG2,QXQ,QXS,QXS2,QX2,RH,RX,SE,SH,SMJ,SW2,SX,TH,TX,TX2,UH,UX,VA,VEX,VH,VS,VSX,VSX1,VS1,VX
			-	2	-	-	2299856	
			-	-	-	2		
11	90203-PB2-000	NUT, AIR CLEANER COVER (DACRO COATING)	1	-	-	-	2185869	HH,HX,LE,LH,LX,PH,PX,QE,QEH,QH,QX,QXG,QXS,RH,RX,SE,SH,SMJ,SW2,SX,TH,TX,UH,UX,VA,VH,VS,VSX,VX
			-	(1)	-	-	2185869	

Ref. No.	Part No.	Description	Reqd. QTY				Serial No.	Parts catalogue code	
			(1)	GX120K1 (2)	(3)	(4)			
11)	90203-ZA0-800	NUT, WING, 6MM(BLACK) .....	1	-	-	-	2299856	HXQ,HX2,LX2,QH2,QXG2,QXQ,QXS2,QX2,TX2	
			1	-	-	-	2336263	LTA,VEX,VSX1,VS1	
			1	-	-	-	2185870	HX,QX,QXG,QXS,TX	
			1	-	-	-	2185870	2336263	HH,LE,LH,LX,PH,PX,QE,QEH,QH,RH,RX,SE,SH,SMJ,SW2,SX,TH,UH,UX,VA VH,VS,VSX,VX
			-	(1)	-	-	2185870	2336263	
12	90325-044-000	NUT, TOOL BOX SETTING .....	1	(1)	-	-	2336263	H1,LTA,LX,PH,PX,Q1,RX,R1,SMJ,SX,TH,UH,UX,U1,VH,VX,V1,W1	
			1	-	-	-	-----	QJW1,SSK1,SSK3,STP	
			1	-	-	-	2299856	HXQ,HX2,LX2,QH2,QXG2,QXQ,QXS2,QX2,TX2	
			1	-	-	-	2329087	HX,QX,QXG,QXS,TX	
			1	-	-	-	3230226	QB26	
			1	-	-	-	3558048	LJT	
			2	-	-	-	3230227	3323432	QB26
			1	-	-	-	-----	LJT,QJW1,SJC1,SSK1,SSK3,STP	
			1	-	-	-	3323433	QB26	
			2	-	-	-	-----	HHQ4,HTF2,HT2,HXU,HX26,HX4,KRF4,KRS4,LAJ4,LEH4,LHQ4,LJD2,LTS LXU,LX26,LX4,PX2,QAA2,QBU2,QH4,QH26,QJG2,QLL,QMA4,QMA8,QMX2 QPU,QTC2,QWA4,QXU,QX26,QX4,QX7,RHC,RHQ4,RX4,SAD2,SAJ4,SG24 SHQ4,SJD2,SMA7,SMW2,SM11,SM12,SM14,SSK2,SSX2,SSX4,SWX2,SWX4 SXS4,SX4,SX7,TX26,TX4,UXU,VAX4,VEK,VEX7,VMS4,VXU,VX4,VX7,WDA6	
			2	-	-	-	2299857	-----	HXQ,HX2,LX2,QH2,QXG2,QXQ,QXS2,QX2,TX2
			2	-	-	-	2329088	-----	HX,QX,QXG,QXS,TX
			2	-	-	-	2336264	-----	HH,LE,LH,LTA,LX,PH,PX,QE,QEH,QH,RH,RX,SE,SH,SMJ,SW2,SX,TH,UH UX,VA,VEX,VH,VS,VSX,VSX1,VS1,VX
			2	-	-	-	2965582	-----	QMH
			2	-	-	-	3093871	-----	VEE1
			2	-	-	-	3558049	-----	LTJ
			-	(2)	-	-	2336264	-----	
13	93494-06020-08	BOLT-WASHER, 6X20 .....	1	-	-	-	-----	HH,HXU,LE,LH,LX,LXU,PH,PX,QE,QEH,QH,QXU,RH,RX,SE,SH,SW2,SX,TH UH,UX,UXU,VA,VH,VS,VSX,VXU	
			-	1	-	1	-----		
			1	-	-	-	2519854	HHQ4,HX,HXQ,HX2,HX4,LHQ4,LTA,LX2,LX4,QAA2,QHQ4,QH2,QLL,QPU,QX QXG,QXG2,QXQ,QXS,QXS2,QX2,QX4,RHC,RHQ4,RX4,SHQ4,SMJ,SSK1,SX4 TX,TX2,TX4,VEX,VSX1,VS1,VX4	
			1	-	-	-	-----	HTF2,HT2,HX26,KRF4,KRS4,LAJ4,LEH4,LJD2,LJT,LTS,LX26,PX2,QBU2 QB26,QH26,QJG2,QJW1,QMA4,QMA8,QMX2,QTC2,QWA4,QX26,QX7,SAD2 SAJ4,SG24,SJD2,SMA7,SMW2,SM11,SM12,SM14,SSK2,SSK3,SSX2,SSX4 STP,SWX2,SWX4,SXS4,SX7,TX26,VAX4,VEK,VEX7,VMS4,VX,VX7,WDA6	
			1	-	-	-	2519855	-----	HHQ4,HX,HXQ,HX2,HX4,LHQ4,LTA,LX2,LX4,QAA2,QHQ4,QH2,QLL,QPU,QX QXG,QXG2,QXQ,QXS,QXS2,QX2,QX4,RHC,RHQ4,RX4,SHQ4,SMJ,SSK1,SX4 TX,TX2,TX4,VEX,VSX1,VS1,VX4
1	-	-	-	2965582	-----	QMH			
1	-	-	-	3093871	-----	VEE1			
1	-	-	-	3558049	-----	LTJ			





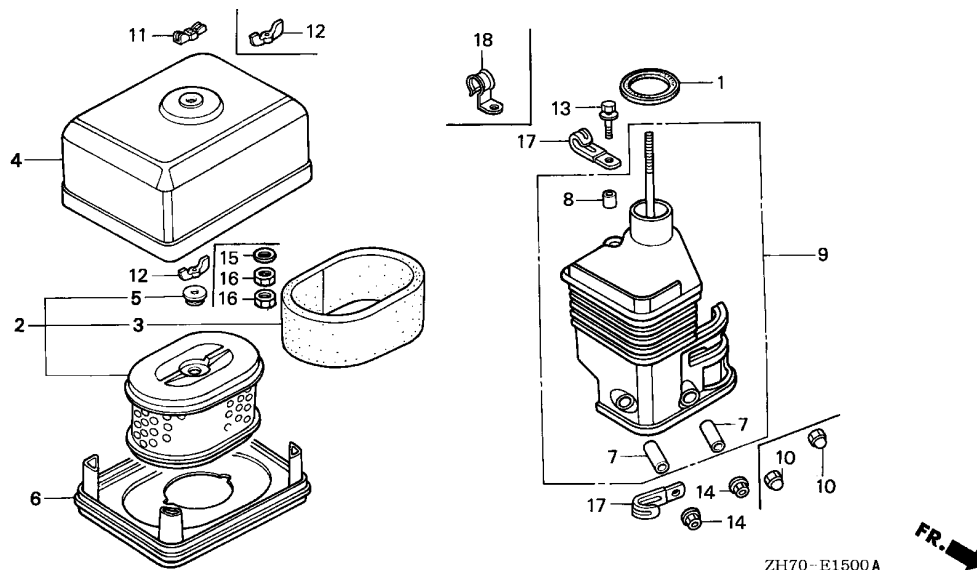

Ref. No.	Part No.	Description	Reqd. QTY				Serial No.	Parts catalogue code	
			(1)	(2)	(3)	(4)			
14	94050-06000	NUT, FLANGE, 6MM .....	2	-	-	-	-----	HHQ4,HTF2,HT2,HXU,HX26,HX4,KRF4,KRS4,LAJ4,LEH4,LHQ4,LJD2,LJT LTS,LXU,LX26,LX4,PX2,QAA2,QBU2,QB26,QHQ4,QH26,QJG2,QJW1,QLL QMA4,QMA8,QMX2,QPU,QTC2,QWA4,QXU,QX26,QX4,QX7,RHQ4,RX4,SAD2 SAJ4,SG24,SHQ4,SJD2,SMA7,SMW2,SM11,SM12,SM14,SSK1,SSK2,SSK3 SSX2,SSX4,STP,SWX2,SWX4,SXS4,SX4,SX7,TX26,TX4,UXU,VAX4,VEK VEX7,VMS4,VXU,VX4,VX7,WDA6	
			2	-	-	-	2299857	-----	HH,HX,HXQ,HX2,LE,LH,LTA,LX,LX2,PH,PX,QE,QEH,QH,QH2,QX,QXG,QXG2 QXQ,QXS,QXS2,QX2,RH,RHC,RX,SE,SH,SMJ,SW2,SX,TH,TX,TX2,UH,UX,VA VEX,VH,VS,VSX,VSX1,VS1,VX
			2	-	-	-	2965582	-----	QMH
			2	-	-	-	3093871	-----	VEE1
			2	-	-	-	3558049	-----	LTJ
			-	2	-	-	2299857	-----	
			-	-	-	2		-----	
15	94101-06800	WASHER, PLAIN, 6MM .....	1	-	-	-	-----	HXU,LXU,QXU,UXU,VXU	
			2	-	-	-	-----	HHQ4,HTF2,HX26,HX4,LAJ4,LEH4,LHQ4,LJT,LTS,LX26,LX4,PX2,QAA2 QBU2,QB26,QHQ4,QH26,QJG2,QJW1,QLL,QMA4,QMA8,QMX2,QPU,QTC2,QWA4 QX26,QX4,RHQ4,RX4,SAD2,SAJ4,SG24,SHQ4,SMA7,SMW2,SM11,SM12,SSK1 SSK2,SSK3,SSX2,SSX4,STP,SWX2,SWX4,SXS4,SX4,TX26,TX4,VAX4,VX4 WDA6	
			2	-	-	-	2299857	-----	HH,HX,HXQ,HX2,LE,LH,LTA,LX,LX2,PH,PX,QE,QEH,QH,QH2,QX,QXG,QXG2 QXQ,QXS,QXS2,QX2,RH,RHC,RX,SE,SH,SMJ,SW2,SX,TH,TX,TX2,UH,UX,VA VEX,VH,VS,VSX,VSX1,VS1,VX
			2	-	-	-	2965582	-----	QMH
			2	-	-	-	3093871	-----	VEE1
			2	-	-	-	3558049	-----	LTJ
			-	2	-	-	2299857	-----	
			-	-	-	1		-----	

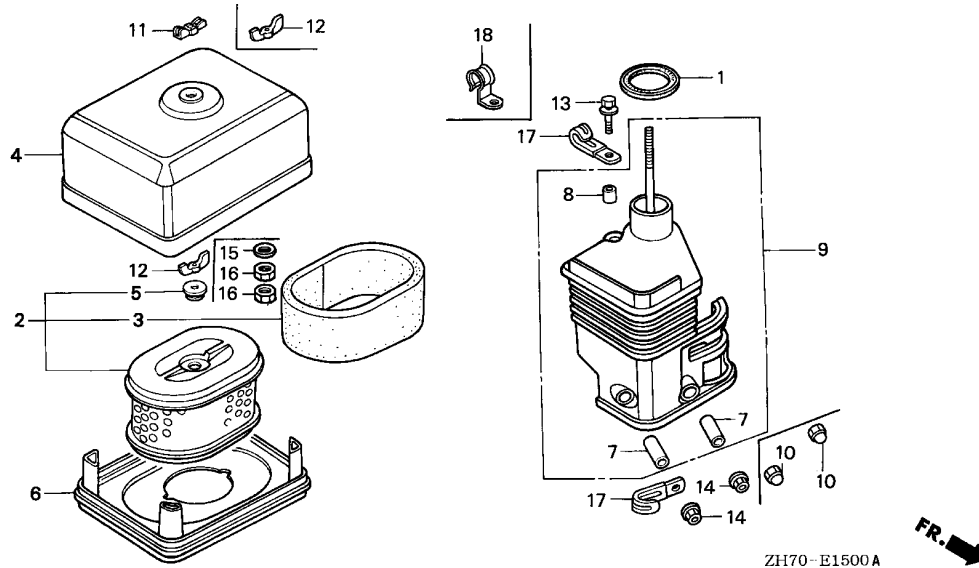

Ref. No.	Part No.	Description	Reqd. QTY				Serial No.	Parts catalogue code
			(1)	(2)	(3)	(4)		
			GX120K1					
16	94001-06000-0S	NUT, HEX., 6MM .....	2	-	-	-	3323433	----- QB26
17	91403-881-000	CLIP B, CORD .....	2	-	-	-	2368680	----- LTA
	35210-MA6-000	CLAMP, SWITCH CORD .....	2	-	-	-	2368681	----- LTA
18	16106-KW7-900	CLIP B, TUBE .....	1	-	-	-	-----	----- KRS4



E-15-1

AIR CLEANER(2)

J 2

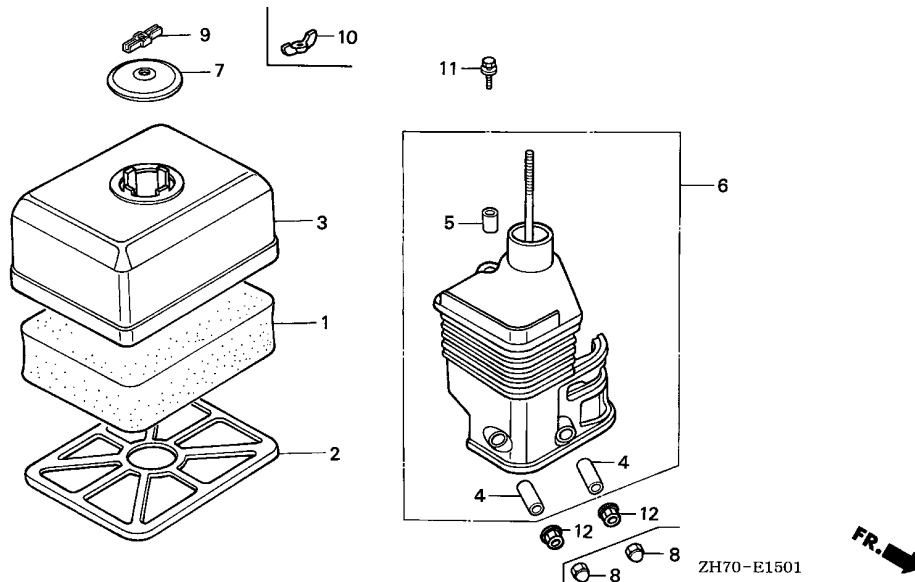

Ref. No.	L.O.N.	(Relative ref. Number) Description	F.R.T.
1	3121B8	ELEMENT, AIR CLEANER .....	0.1
6	3121B4	ELBOW, AIR CLEANER .....	0.1

Ref. No.	Part No.	Description	Reqd. QTY				Serial No.	Parts catalogue code
			(1)	(2)	(3)	(4)		
1	17211-ZE1-000	ELEMENT, AIR CLEANER (SEMI DRY)	1	-	1	-	-----	DS,EN,ET,ETX,LD,LDB1,LDB3,LD4,LJ,LJC,LJS,LSJ,LSJ4,LTR,PM,PM2
			1	-	-	-	-----	3093870 VEE1
2	17212-ZE1-000	GRID, AIR CLEANER (SEMI DRY)	-	(1)	-	-	-----	3558048 LTJ
			1	-	1	-	-----	DS,EN,ET,ETX,LD,LDB1,LDB3,LD4,LJ,LJC,LJS,LSJ,LSJ4,LTR,PM,PM2
3	17231-ZE0-000	COVER, AIR CLEANER (SEMI DRY)	1	-	1	-	-----	QD,QM,QSJ,RD,RD4,SAJ,SCJ,SD,SDB1,SDB3,SD16,SD4,SJ,SJC,SJC1
			1	-	-	-	-----	3093870 VEE1
4	17238-ZE0-010	COLLAR, AIR CLEANER .....	-	(1)	-	-	-----	3558048 LTJ
			2	-	2	-	-----	DS,EN,ET,ETX,LD,LDB1,LDB3,LD4,LJ,LJC,LJS,LSJ,LSJ4,LTR,PM,PM2
			2	-	-	-	-----	3093870 VEE1
			2	-	-	-	-----	3558048 LTJ
			-	(2)	-	-	-----	

2

E-15-1

AIR CLEANER(2)



Ref. No.	Part No.	Description	Reqd. QTY				Serial No.	Parts catalogue code
			(1)	GX120K1 (2)	(3)	(4)		
5	17239-ZE1-000	COLLAR B, AIR CLEANER .....	1	-	1	-	DS,EN,ET,ETX,LD,LDB1,LDB3,LD4,LJ,LJC,LJS,LSJ,LSJ4,LTR,PM,PM2,QD,QM,QSJ,RD,RD4,SAJ,SCJ,SD,SDB1,SDB3,SD16,SD4,SJ,SJC,SJC1,SJC5,SKJ,SKR,SN,UIH,VED,VED1,VED6,VET,WDJ,WD12,WIH1,WJ,WJP,WJP1,WJ1,WKD6,WKT2,WKT4,WKT6,WMA3,WME2,WME4,WM1	
			1	-	-	-	3093870 VEE1	
			1	-	-	-	3558048 LTJ	
			-	(1)	-	-		
6	17410-ZE0-030	ELBOW COMP., AIR CLEANER ....	1	-	1	-	DS,EN,ET,ETX,LD,LDB1,LDB3,LD4,LJ,LJC,LJS,LSJ,LSJ4,LTR,PM,PM2,QD,QM,QSJ,RD,RD4,SAJ,SCJ,SD,SDB1,SDB3,SD16,SD4,SJ,SJC,SJC1,SJC5,SKJ,SKR,SN,UIH,VED,VED1,VED6,VET,WDJ,WD12,WIH1,WJ,WJP,WJP1,WJ1,WKD6,WKT2,WKT4,WKT6,WMA3,WME2,WME4,WM1	
			1	-	-	-	3093870 VEE1	
			1	-	-	-	3558048 LTJ	
			-	(1)	-	-		
	17410-ZE0-811	.....	-	(1)	-	-	H1,Q1,R1,U1,V1,W1	
7	17421-ZE1-000	CAP, CLEANER .....	1	-	1	-	DS,EN,ET,ETX,LD,LDB1,LDB3,LD4,LJ,LJC,LJS,LSJ,LSJ4,LTR,PM,PM2,QD,QM,QSJ,RD,RD4,SAJ,SCJ,SD,SDB1,SDB3,SD16,SD4,SJ,SJC,SJC5,SKJ,SKR,SN,UIH,VED,VED1,VED6,VET,WDJ,WD12,WIH1,WJ,WJP,WJP1,WJ1,WKD6,WKT2,WKT4,WKT6,WMA3,WME2,WME4,WM1	
			1	-	-	-	3093870 VEE1	
			1	-	-	-	3558048 LTJ	
			-	(1)	-	-		
8	90201-415-000	NUT, CAP, 6MM .....	2	-	-	-	2299856 DS,EN,ET,ETX,LD,LJ,LTJ,PM,PM2,QD,QM,QSJ,RD,SD,SJ,SKJ,SN,VED,VED1,VET,WJ	
			-	2	-	-	2299856	
			-	-	2	-	UIH	
9	90203-PB2-000	NUT, AIR CLEANER COVER (DACRO COATING)	1	-	-	-	2185869 EN,ET,ETX,LD,PM,PM2,QD,QM,RD,SD,SN,VED,VED1	
			-	(1)	-	-	2185869	
	90203-ZA0-800	NUT, WING, 6MM(BLACK) .....	1	-	1	-	2336263 LTJ,SKJ,UIH	
			1	-	-	-	2185870 2336263 DS,EN,ET,ETX,LD,LJ,PM,PM2,QD,QM,QSJ,RD,SD,SJ,SN,VED,VED1,VET,WJ	
			-	(1)	-	-	2185870 2336263	
10	90325-044-000	NUT, TOOL BOX SETTING .....	1	-	1	-	LDB1,LDB3,LD4,LJC,LJS,LSJ,LSJ4,LTR,RD4,SAJ,SCJ,SDB1,SDB3,SD16,SD4,SJC,SJC1,SJC5,SKR,VED6,WDJ,WD12,WIH1,WJP,WJP1,WJ1,WKD6,WKT2,WKT4,WKT6,WMA3,WME2,WME4,WM1	
			1	-	1	-	2336264 DS,EN,ET,ETX,LD,LJ,PM,PM2,QD,QM,QSJ,RD,SD,SJ,SKJ,SN,UIH,VED,VED1,VET,WJ	
			1	-	-	-	3093870 VEE1	
			1	-	-	-	3558048 LTJ	
			-	(1)	-	-	2336264	
11	93494-06020-08	BOLT-WASHER, 6X20 .....	1	-	1	-	DS,LD,LJ,PM,PM2,QD,QM,RD,SD,SJ,SN,UIH,VET,WJ	
			-	1	-	-		
	93404-06020-08	.....	1	-	-	-	2519854 EN,ET,ETX,LD4,LTJ,QSJ,RD4,SCJ,SD4,SKJ,VED,VED1,WJP	
	95701-06020-00	BOLT, FLANGE, 6X20 .....	1	-	1	-	LDB1,LDB3,LJC,LJS,LSJ,LSJ4,LTR,SAJ,SDB1,SDB3,SD16,SJC,SJC1,SJC5,SKR,VED6,WDJ,WD12,WIH1,WJP1,WJ1,WKD6,WKT2,WKT4,WKT6,WMA3,WME2,WME4,WM1	
			1	-	-	-	2519855 EN,ET,ETX,LD4,QSJ,RD4,SCJ,SD4,SKJ,VED,VED1,WJP	
			1	-	-	-	3093870 VEE1	
			1	-	-	-	3558048 LTJ	
			-	(1)	-	-	2519855	
12	94050-06000	NUT, FLANGE, 6MM .....	2	-	2	-	LDB1,LDB3,LD4,LJC,LJS,LSJ,LSJ4,LTR,RD4,SAJ,SCJ,SDB1,SDB3,SD16,SD4,SJC,SJC1,SJC5,SKR,UIH,VED6,WDJ,WD12,WJP,WJP1,WJ1,WKD6,WKT2,WKT4,WKT6,WMA3,WME2,WME4,WM1	
			2	-	-	-	2299857 DS,EN,ET,ETX,LD,LJ,PM,PM2,QD,QM,QSJ,RD,SD,SJ,SKJ,SN,VED,VED1,VET,WJ	
			2	-	-	-	3093870 VEE1	
			2	-	-	-	2299857 3558048 LTJ	
			-	2	-	-	2299857	



E-15-2

AIR CLEANER(3)

J 4

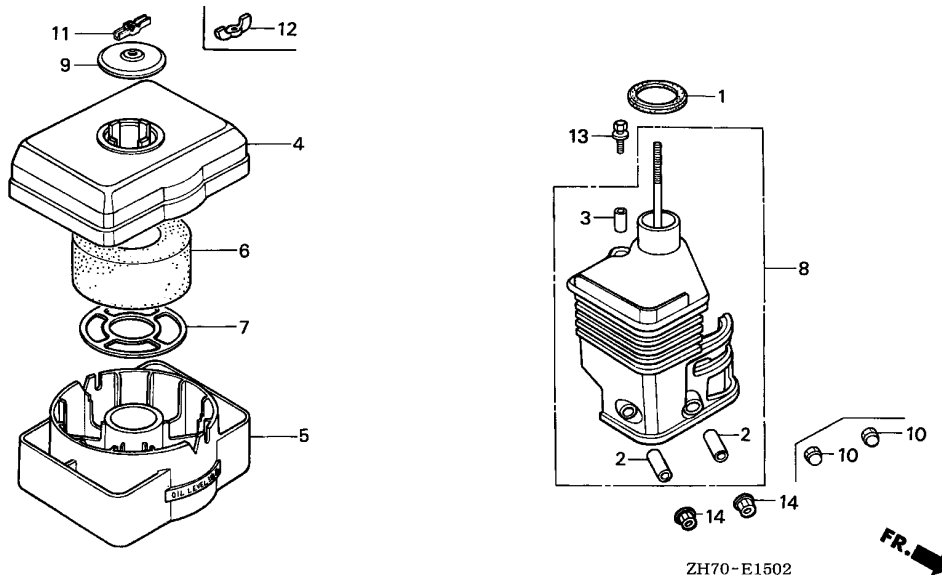

Ref. No.	L.O.N.	(Relative ref. Number) Description	F.R.T.
1	3121E1	PACKING, ELBOW .....	0.1
5	3121E5	PAN, AIR CLEANER OIL .....	0.1
6	3121B8	ELEMENT, AIR CLEANER .....	0.1
8	3121B4	ELBOW, AIR CLEANER .....	0.1

2

Ref. No.	Part No.	Description	Reqd. QTY				Serial No.	Parts catalogue code
			(1)	(2)	(3)	(4)		
1	16271-ZE1-000	PACKING, ELBOW .....	1	-	1	-	LTK1,LW2,QA,QA2,QA26,QIH1,QME4,QT 2965581 QMH	
2	17238-ZE0-010	COLLAR, AIR CLEANER .....	2	(1)	-	-	LTK1,LW2,QA,QA2,QA26,QIH1,QME4,QT 2965581 QMH	
3	17239-ZE1-000	COLLAR B, AIR CLEANER .....	1	(2)	-	-	LTK1,LW2,QA,QA2,QA26,QIH1,QME4,QT 2965581 QMH	
4	17401-ZE1-810	BODY, CLEANER (OIL BATH) ....	1	(1)	-	-	LTK1,LW2,QA,QA2,QA26,QIH1,QME4,QT 2965581 QMH	
5	17402-ZE1-810	PAN, CLEANER OIL (OIL BATH) -	1	(1)	-	-	LTK1,LW2,QA,QA2,QA26,QIH1,QME4,QT 2965581 QMH	
6	17403-ZE1-810	ELEMENT, AIR CLEANER (OIL BATH)	1	-	1	-	LTK1,LW2,QA,QA2,QA26,QIH1,QME4,QT 2965581 QMH	
7	17404-841-000	GRID, AIR CLEANER .....	1	(1)	-	-	LTK1,LW2,QA,QA2,QA26,QIH1,QME4,QT 2965581 QMH	
8	17410-ZE0-811	ELBOW COMP., AIR CLEANER ....	1	(1)	-	-	LTK1,LW2,QA,QA2,QA26,QIH1,QME4,QT 2965581 QMH	
9	17421-ZE1-000	CAP, CLEANER .....	1	(1)	-	-	LTK1,LW2,QA,QA2,QA26,QIH1,QME4,QT 2965581 QMH	

E-15-2

AIR CLEANER(3)

J 5

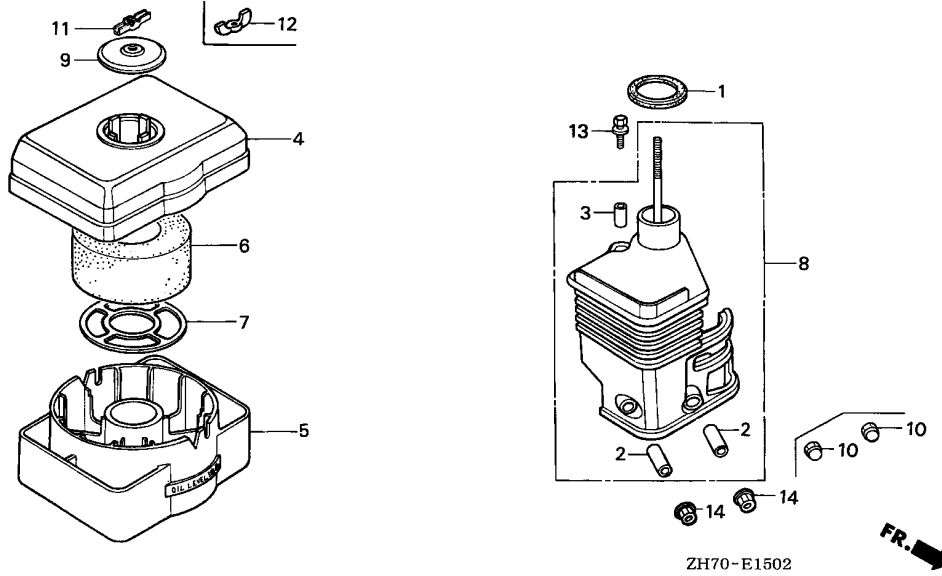

Ref. No.	Part No.	Description	Reqd. QTY				Serial No.	Parts catalogue code
			(1)	(2)	(3)	(4)		
10	90201-415-000	NUT, CAP, 6MM .....	2	-	-	-	2299856 LW2,QA,QA2,QT	
			-	2	-	-	2299856	
11	90203-PB2-000	NUT, AIR CLEANER COVER (DACRO COATING)	1	-	-	-	2185869 LW2,QA,QT	
			-	(1)	-	-	2185869	
	90203-ZA0-800	NUT, WING, 6MM(BLACK) .....	1	-	-	-	QA2	
			1	-	-	2185870	2336263 LW2,QT	
			1	-	-	2185870	3228266 QA	
			-	(1)	-	2185870	2336263	
12	90325-044-000	NUT, TOOL BOX SETTING .....	1	-	1	-	LTK1,QA26,QIH1,QME4	
			1	-	-	2336264	LW2,QT	
			1	-	-	3228267	QA	
			1	-	-	-	2965581 QMH	
			-	(1)	-	2336264	-	
13	93404-06020-08	BOLT-WASHER, 6X20 .....	1	-	-	-	2519854 QA,QA2	
	93494-06020-08	.....	1	-	-	-	LW2,QT	
			-	1	-	-	-	
	95701-06020-00	BOLT, FLANGE, 6X20 .....	1	-	1	-	QA26,QIH1,QME4	
			1	-	-	2519855	QA,QA2	
			1	-	-	-	2965581 QMH	
14	94050-06000	NUT, FLANGE, 6MM .....	2	-	2	-	LTK1,QA26,QIH1,QME4	
			2	-	-	2299857	LW2,QA,QA2,QT	
			2	-	-	-	2965581 QMH	
			-	2	-	2299857	-	

2

E-15-3

AIR CLEANER(4)

J 6

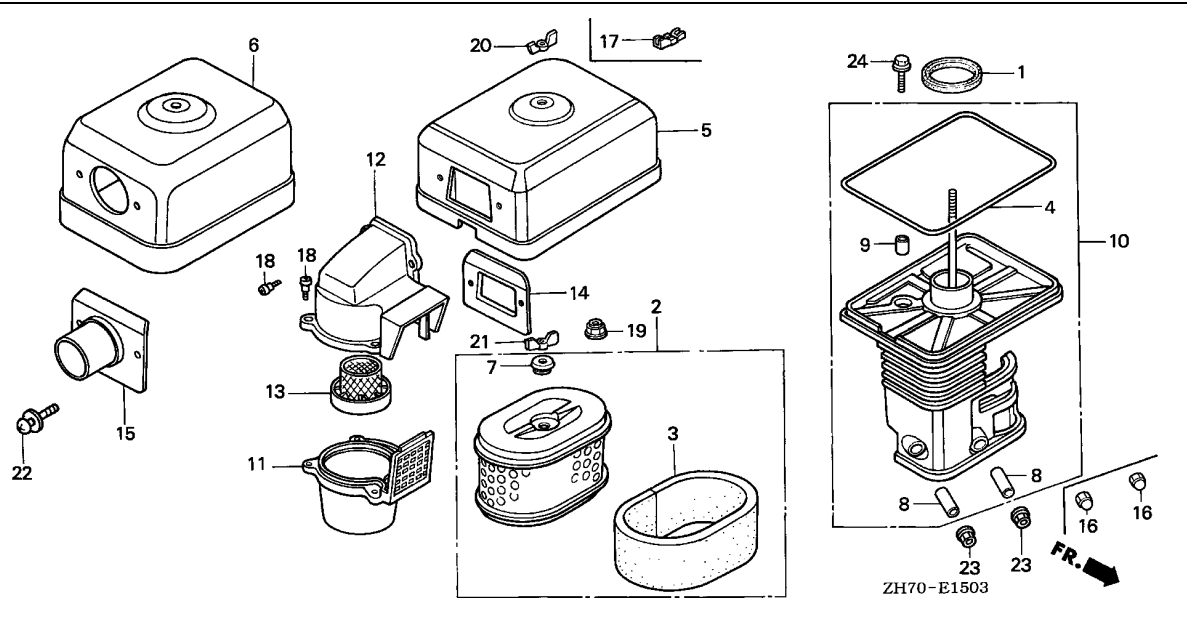

Ref. No.	L.O.N.	(Relative ref. Number) Description	F.R.T.
1	3121E1	PACKING, ELBOW .....	0.1
2	3121B8	ELEMENT, AIR CLEANER .....	0.1
3	3121C1	FILTER, OUTER .....	0.1
4	3121E0	PACKING, AIR CLEANER COVER ...	0.1
10	3121B4	ELBOW, AIR CLEANER .....	0.1
11	3121A6	CASE, PRE AIR CLEANER .....	0.1
12	3121A4	CAP, PRE AIR CLEANER .....	0.1
13	3121C8	GUIDE, PRE AIR CLEANER .....	0.1

2

Ref. No.	Part No.	Description	Reqd. QTY				Serial No.	Parts catalogue code
			(1)	(2)	(3)	(4)		
1	16271-ZE1-000	PACKING, ELBOW .....	1	-	-	-	----- QXC,QXC9,STS	
2	17210-ZE1-822	ELEMENT, AIR CLEANER (DUAL) ..	1	-	-	-	----- QXC,QXC9,STS	
3	17218-ZE1-821	FILTER, OUTER .....	1	-	-	-	----- QXC,QXC9,STS	
4	17219-733-010	PACKING, AIR CLEANER COVER ..	1	-	-	-	----- QXC,QXC9,STS	
5	17230-ZE1-841	COVER, AIR CLEANER (DUAL) ...	1	-	-	-	----- QXC,QXC9	
6	17230-ZE1-850	COVER, AIR CLEANER .....	1	-	-	-	----- STS	
7	17232-891-000	GROMMET, AIR CLEANER .....	1	-	-	-	----- QXC,QXC9,STS	
8	17238-ZE0-010	COLLAR, AIR CLEANER .....	2	-	-	-	----- QXC,QXC9,STS	
9	17239-733-000	COLLAR B, AIR CLEANER .....	1	-	-	-	----- QXC,QXC9,STS	
10	17410-ZE0-840	ELBOW COMP., AIR CLEANER ....	1	-	-	-	----- QXC,QXC9,STS	
11	17470-ZE1-841	CASE, PRE AIR CLEANER .....	-	(1)	-	-	----- U1,V1	
	17470-ZE1-842	.....	1	(1)	-	-	----- H1,L1,QXC,QXC9,Q1,R1,S1,W1	
12	17475-ZE1-841	CAP, PRE AIR CLEANER .....	1	-	-	-	----- QXC,QXC9	
		.....	-	(1)	-	-		
13	17476-ZE1-841	GUIDE, PRE AIR CLEANER .....	1	-	-	-	----- QXC,QXC9	
		.....	-	(1)	-	-		
14	17478-ZE1-841	PLATE, PRE AIR CLEANER .....	1	-	-	-	----- QXC,QXC9	
		.....	-	(1)	-	-		

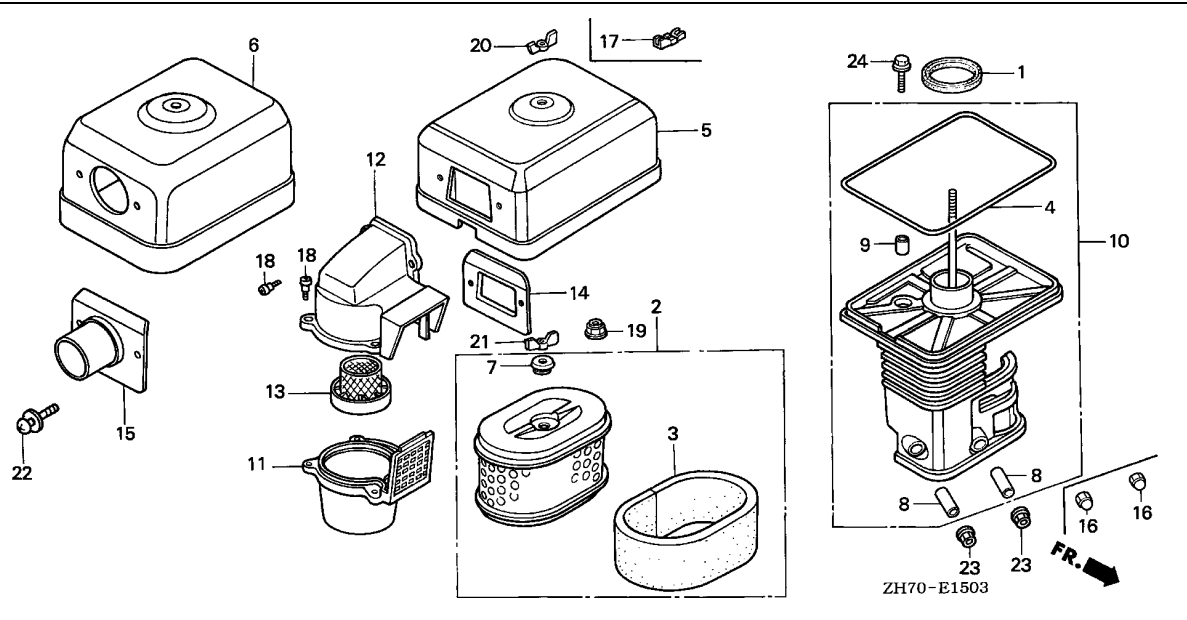

Ref. No.	Part No.	Description	Reqd. QTY				Serial No.	Parts catalogue code
			(1)	(2)	(3)	(4)		
15	17478-ZE1-850	PLATE, PRE AIR CLEANER	1	-	-	-	----- STS	
16	90201-415-000	NUT, CAP, 6MM	2	-	-	-	----- 2299856 QXC,STS	
17	90203-PB2-000	NUT, AIR CLEANER COVER (DACRO COATING)	1	-	-	-	----- 2185869 QXC	
			-	(1)	-	-	----- 2185869	
	90203-ZA0-800	NUT, WING, 6MM(BLACK)	1	-	-	-	----- 2336263 STS	
			1	-	-	-	----- 2185870 2329087 QXC	
			-	(1)	-	-	----- 2185870 2336263	
18	90300-GB0-900	BOLT, MUDGUARD	5	-	-	-	----- QXC,QXC9	
			-	(5)	-	-	-----	
19	90301-473-003	NUT, U, 6MM	1	-	-	-	----- STS	
20	90325-044-000	NUT, TOOL BOX SETTING	1	-	-	-	----- QXC9	
			1	-	-	-	----- 2336264 STS	
			-	(1)	-	-	----- 2336264	
			1	-	-	-	----- 2329088 QXC	
21	90325-044-000	NUT, TOOL BOX SETTING	1	-	-	-	----- QXC,QXC9	
			-	(1)	-	-	-----	
22	93893-04012-07	SCREW-WASHER, 4X12	2	-	-	-	----- STS	
23	94050-06000	NUT, FLANGE, 6MM	2	-	-	-	----- QXC9	
			2	-	-	-	----- 2299857 QXC,STS	
			-	2	-	-	----- 2299857	
24	95700-06020-00	BOLT, FLANGE, 6X20	1	(1)	-	-	----- H1,QXC,Q1,R1,STS,U1,V1,W1	
	95701-06020-00		1	-	-	-	----- QXC9	
			-	(1)	-	-	-----	





E-15-4

AIR CLEANER(5)

J 8

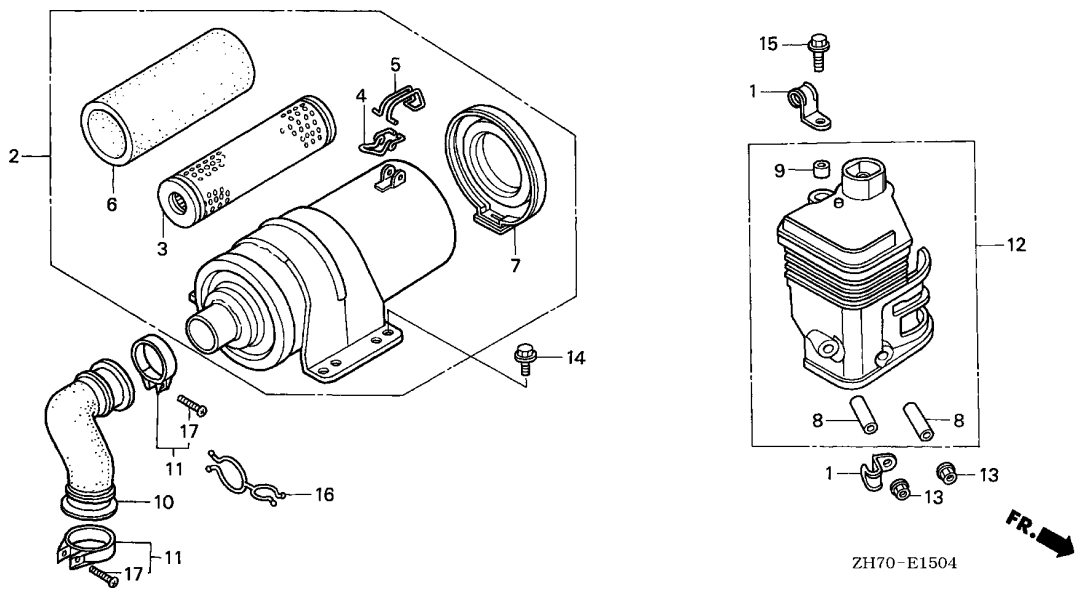

Ref. No.	L.O.N.	(Relative ref. Number) Description	F.R.T.
2	3121B0	CLEANER, AIR .....	0.1
3	3121B8	ELEMENT, AIR CLEANER .....	0.1
6	3121C1	FILTER, OUTER .....	0.1
10	3121F9	TUBE, AIR CLEANER INTAKE .....	0.1
12	3121B4	ELBOW, AIR CLEANER .....	0.1

2

Ref. No.	Part No.	Description	Reqd. QTY				Serial No.	Parts catalogue code
			(1)	(2)	(3)	(4)		
1	16106-KW7-900	CLIP B, TUBE .....	1	-	-	-	AR,DKR,KRA4	
2	17200-ZK7-V01	CLEANER ASSY., AIR .....	1	-	-	-	AR,DKR,KR,KRA4,KRT,KRT4,KRT6	
3	17210-ZK7-V01	ELEMENT COMP., AIR CLEANER ..	1	-	-	-	AR,DKR,KR,KRA4,KRT,KRT4,KRT6	
4	17216-PM4-300	CLIP A, WIRE .....	1	-	-	-	AR,DKR,KR,KRA4,KRT,KRT4,KRT6	
5	17217-PM4-300	CLIP B, WIRE .....	1	-	-	-	AR,DKR,KR,KRA4,KRT,KRT4,KRT6	
6	17218-ZK7-V01	FILTER, OUTER .....	1	-	-	-	AR,DKR,KR,KRA4,KRT,KRT4,KRT6	
7	17230-ZK7-V01	COVER COMP., AIR CLEANER .....	1	-	-	-	AR,DKR,KR,KRA4,KRT,KRT4,KRT6	
8	17238-ZE7-010	COLLAR, AIR CLEANER .....	2	-	-	-	AR,DKR,KR,KRA4,KRT,KRT4,KRT6	
9	17239-ZE1-000	COLLAR B, AIR CLEANER .....	1	-	-	-	AR,DKR,KR,KRA4,KRT,KRT4,KRT6	
10	17251-ZE0-S10	TUBE, AIR CLEANER CONNECTING	1	-	-	-	AR,DKR,KR,KRA4,KRT,KRT4,KRT6	
11	17255-758-000	BAND, AIR CLEANER CONNECTING TUBE	2	-	-	-	AR,DKR,KR,KRA4,KRT,KRT4,KRT6	
12	17410-ZE1-P30	ELBOW COMP., AIR CLEANER .....	1	-	-	-	AR,DKR,KR,KRA4,KRT,KRT4,KRT6	
13	94050-06000	NUT, FLANGE, 6MM .....	2	-	-	-	AR,DKR,KR,KRA4,KRT,KRT4,KRT6	
14	95701-06016-00	BOLT, FLANGE, 6X16 .....	2	-	-	-	AR,DKR,KR,KRA4,KRT,KRT4,KRT6	
15	95701-06020-00	BOLT, FLANGE, 6X20 .....	1	-	-	-	KRT,KRT4,KRT6	
	90013-883-000	BOLT, FLANGE, 6X12(CT200) .....	1	-	-	-	AR,DKR,KR,KRA4	
16	91473-PA1-003	CLIP, WATER HOSE .....	1	-	-	-	AR,DKR,KR,KRA4,KRT,KRT4,KRT6	
17	93500-04020-0A	SCREW, PAN, 4X20 .....	2	-	-	-	AR,DKR,KR,KRA4,KRT,KRT4,KRT6	

E-15-5

AIR CLEANER(6)

J 9

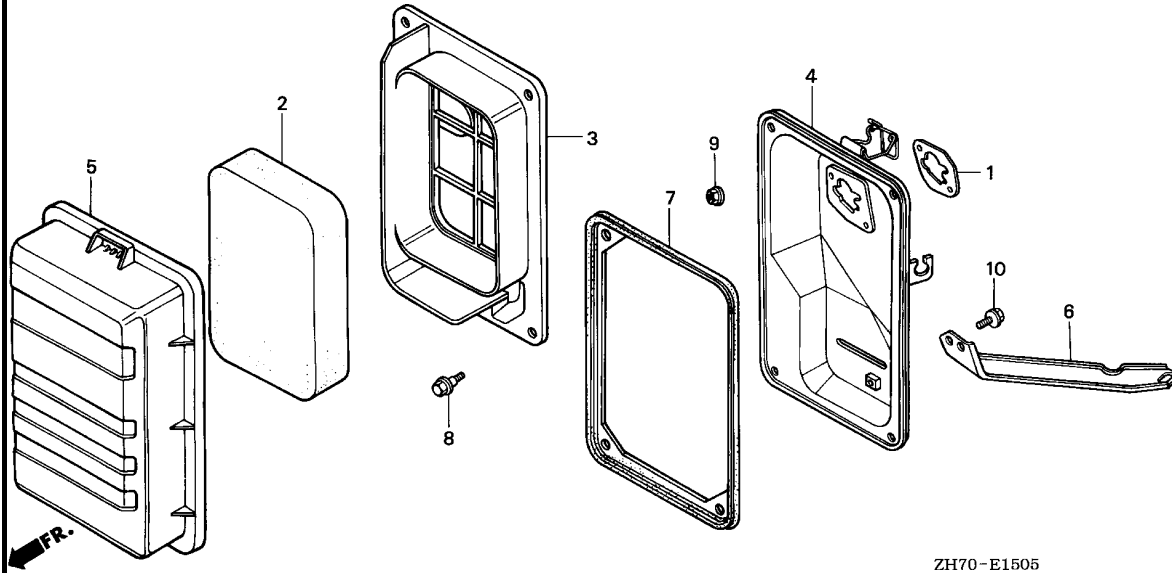

Ref. No.	L.O.N.	(Relative ref. Number) Description	F.R.T.
1	3121D9	PACKING, AIR CLEANER .....	0.1
2	3121B8	ELEMENT, AIR CLEANER .....	0.1
3	3121F0	SEPARATOR, AIR CLEANER .....	0.1
4	3121A5	CASE, AIR CLEANER .....	0.1
7	3121E8	SEAL, AIR CLEANER CASE .....	0.1

Ref. No.	Part No.	Description	Reqd. QTY				Serial No.	Parts catalogue code
			(1)	(2)	(3)	(4)		
1	16269-ZE1-800	PACKING, AIR CLEANER .....	1	-	-	-	-----	VMT,VPR4
2	17211-ZB2-000	ELEMENT, AIR CLEANER .....	1	-	-	-	-----	VMT,VPR4
3	17212-ZB2-000	SEPARATOR, AIR CLEANER .....	1	-	-	-	-----	VMT,VPR4
4	17220-ZB2-000	CASE COMP., AIR CLEANER .....	1	-	-	-	-----	VMT,VPR4
5	17231-ZB2-000	COVER, AIR CLEANER .....	1	-	-	-	-----	VMT,VPR4
6	17239-ZB2-000	STAY, AIR CLEANER .....	1	-	-	-	-----	VMT,VPR4
7	17252-ZB2-000	SEAL, AIR CLEANER .....	1	-	-	-	-----	VMT,VPR4
8	90115-459-770	BOLT, WINKER SETTING .....	4	-	-	-	-----	VMT,VPR4
9	94050-06080	NUT, FLANGE, 6MM .....	2	-	-	-	-----	VMT,VPR4
10	95701-06010-00	BOLT, FLANGE, 6X10 .....	1	-	-	-	-----	VMT,VPR4

2

E-16

MUFFLER(1)

J10

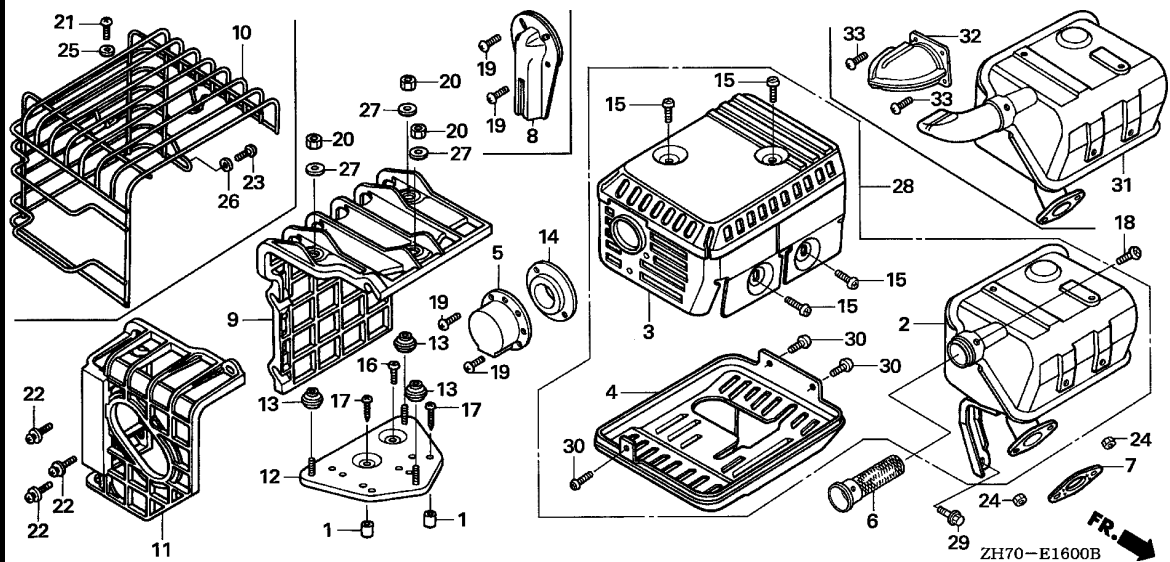

Ref. No.	L.O.N.	(Relative ref. Number) Description	F.R.T.
2	3131C5	(31) MUFFLER, EXHAUST .....	0.2
3	3131D5	PROTECTOR, EXHAUST MUFFLER :UPPER .....	0.2
4	3131D2	PROTECTOR, EXHAUST MUFFLER :LOWER .....	0.2
6	3131A1	ARRESTER, SPARK .....	0.2
7	3131B4	GASKET, EXHAUST MUFFLER .....	0.2
9	3131A7	COVER, EXHAUST MUFFLER .....	0.1
11	3131A6	COVER, EXHAUST MUFFLER :REAR ..	0.1
12	3131A2	BASE, EXHAUST MUFFLER COVER ..	0.2

Ref. No.	Part No.	Description	Reqd. QTY				Serial No.	Parts catalogue code
			(1)	(2)	(3)	(4)		
1	17233-896-701	COLLAR, AIR CLEANER CASE .....	(2)	-	-	-	HHQ4, HX4, LAJ4, LD4, LEH4, LHQ4, LSJ4, LX4, QEH, QHQ4, QLL, QMA4, QME4, QPU, QX4, QX7, RD4, RHQ4, RX4, SAJ4, SD4, SHQ4, SXS4, SX4, SX7, TX4, VEX, VEX7, VX4, VX7, WDA6, WD12, WKT4, WMA3, WM1	
2	18310-ZF1-000	MUFFLER COMP. (STD) .....	1	-	-	-	DS, EN, ET, ETX, HH, HHQ4, HTF2, HT2, HX, HXQ, HXU, HX2, HX26, HX4, LAJ4, LD, LDB1, LDB3, LD4, LEH4, LH, LHQ4, LJ, LJC, LJD2, LJS, LJT, LSJ, LSJ4, LTJ, LTK1, LTR, LTS, LW2, LX, LXU, LX2, LX26, LX4, PH, PM, PM2, PX, PX2, QD, QEH, QH, QHQ4, QH2, QH26, QJG2, QJW1, QLL, QM, QMA4, QME4, QMH, QPU, QSJ, QT, QX, QXG, QXG2, QXQ, QXS, QXS2, QXU, QX2, QX26, QX4, RD, RD4, RH, RHQ4, RX, RX4, SAJ, SAJ4, SCJ, SD, SDB1, SDB3, SD16, SD4, SH, SHQ4, SJ, SJC, SJC1, SJC5, SKJ, SKR, SMJ, SN, SWX2, SWX4, SW2, SX, SX4, TH, TX, TX2, TX26, TX4, UH, UX, UXU, VED, VET, VEX, VH, VS, VS1, VX, VXU, VX4, WDA6, WDJ, WJ, WJP, WJP1, WJ1, WMA3, WME4, WM1	
			1	-	-	3230227	QB26	
			1	-	-	2119399	STS	
			1	-	-	3904652	SXS4	
			(1)	1	1			
	18310-ZH8-810	MUFFLER COMP. (ARRESTER) .....	1	-	-	-	HX26, QA, QAA2, QA2, QA26, QMX2, QTC2, QX26, QX7, RHC, SMW2, SX7, TX26, VA, VED1, VED6, VEX7, VX7, WD12, WKD6, WKT2, WKT4, WKT6, WME2	
			(1)	-	-	-	HTF2, HT2, HX, HXQ, HX2, HX4, QJG2, QJW1, QLL, QX, QXG, QXG2, QXQ, QXS, QXS2, QX2, QX4, SWX2, SWX4, TX, TX2, TX4	
			(1)	-	-	3904653	SXS4	
			(1)	-	-			
	18310-ZE1-900	MUFFLER COMP. ....	1	-	-	-	STP	
			1	-	-	2119400	STS	
			1	-	-	2249340	LTA	
	18310-ZH7-V90	.....	1	-	-	-	SM11, SM14	
			1	-	-	2249341	LTA	
	18310-ZH8-T30	MUFFLER COMP. (SAKAI-ARRESTER)	1	-	-	-	SSK1, SSK2, SSK3, SSX2, SSX4	
	18310-ZK8-V50	MUFFLER COMP. ....	1	-	-	-	SM12	

Ref. No.	Part No.	Description	Reqd. QTY				Serial No.	Parts catalogue code
			(1)	GX120K1 (2)	(3)	(4)		
3	18321-ZH8-000	PROTECTOR, UPPER .....	1	-	-	-	2029904 DS,HH,HX,LD,LH,LJ,LW2,LX,PH,PM,PM2,PX,QA,QD,QH,QM,QT,QX,QXG,QXS,RD,RH,RX,SD,SH,SJ,SN,SW2,SX,TH,TX,UH,UX,VA,VED,VED1,VET,VH,VX,WJ	
	18320-ZF1-H00	PROTECTOR, MUFFLER (STD.) ...	1	(1)	-	-	2029905 2470940 DS,HH,HX,H1,LD,LH,LJ,LW2,LX,L1,PH,PM,PM2,PX,QA,QD,QH,QM,QT,QX,QXG,QXS,Q1,RD,RH,RX,R1,SD,SH,SJ,SN,SW2,SX,S1,TH,TX,UH,UX,VA,VED,VED1,VET,VH,VX,V1,WJ,W1	
			1	-	-	-	2119399 STS	
			1	-	-	-	2470940 EN,ET,ETX,HXQ,HX2,LTJ,LX2,QAA2,QA2,QEH,QH2,QLL,QPU,QSJ,QXG2,QXQ,QXS2,QX2,RHC,SCJ,SKJ,SMJ,SSK1,TX2,VEX,VS,VS1	
	18320-ZE1-000	PROTECTOR, UPPER .....	1	-	-	-	2249341 2470940 LTA	
			1	(1)	-	-	2029905 U1	
			1	-	-	-	2249340 LTA	
	18320-ZF1-H00	PROTECTOR, MUFFLER (STD.) ...	1	-	-	-	2119400 2432207 STS	
	18320-ZF1-H01	PROTECTOR, MUFFLER (STD.) (BLACK)	1	(1)	-	-	2432208 STS	
			1	(1)	-	-	2470941 DS,EN,ET,ETX,HH,HX,HXQ,HX2,H1,LD,LH,LJ,LTA,LTJ,LW2,LX,LX2,L1,PH,PM,PM2,PX,QA,QAA2,QA2,QD,QEH,QH,QH2,QLL,QM,QPU,QSJ,QT,QX,QXG,QXG2,QXQ,QXS,QXS2,QX2,Q1,RD,RH,RHC,RX,R1,SCJ,SD,SH,SJ,SKJ,SMJ,SN,SSK1,SW2,SX,S1,TH,TX,TX2,UH,UX,VA,VED,VED1,VET,VEX,VH,VS,VS1,VX,V1,WJ,W1	
			1	-	-	-	HHQ4,HTF2,HT2,HXU,HX26,HX4,LAJ4,LDB1,LDB3,LD4,LEH4,LHQ4,LJC,LJD2,LJS,LJT,LSJ,LSJ4,LTK1,LTR,LTS,LXU,LX26,LX4,PX2,QA26,QHQ4,QH26,QJG2,QJW1,QMA4,QME4,QMH,QMX2,QTC2,QXU,QX26,QX4,QX7,RD4,RHQ4,RX4,SAJ,SAJ4,SDB1,SDB3,SD16,SD4,SHQ4,SJC,SJC1,SJC5,SKR,SMW2,SM11,SM12,SM14,SSK2,SSK3,SSX2,SSX4,STP,SWX2,SWX4,SXS4,SX4,SX7,TX26,TX4,UXU,VED6,VEK,VEX7,VXU,VX4,VX7,WDA6,WDJ,WD12,WJP,WJP1,WKD6,WKT2,WKT4,WKT6,WMA3,WME2,WME4	
			1	-	-	-	2477101 STS	
			1	-	-	-	3230227 3303356 QB26	
			-	-	-	1	2029905	
	18320-ZH8-W01	PROTECTOR, MUFFLER (ALUMINAIZED)	1	-	-	-	WJ1,WM1	
	18320-ZE1-T02	PROTECTOR, UPPER (CHROME) ...	-	-	1	-		
	18320-ZF1-H01	PROTECTOR, MUFFLER (STD.) (BLACK)	-	-	1	-	QIH1,WIH1	
4	18325-ZE1-010	PROTECTOR, LOWER .....	1	-	-	-	DS,LJ,LJC,LJS,LJT,LSJ,LTJ,LTK1,LTR,LTS,QSJ,QXS,QXS2,SAJ,SCJ,SJ,SJC,SJC1,SJC5,SKJ,SKR,SMJ,VEK,VET,WJ,WJP,WJP1	
			1	-	-	-	2119399 STS	
5	18340-ZE1-010	DEFLECTOR COMP. ....	1	(1)	-	-	HTF2,LAJ4,LEH4,LJD2,LJS,LJT,LSJ,LSJ4,LTJ,LTK1,LTR,LW2,QA,QAA2,QA2,QA26,QEH,QIH1,QJW1,QLL,QMA4,QMH,QMX2,QPU,QT,QTC2,SAJ,SAJ4,SCJ,SJC,SJC1,SJC5,SMW2,SM11,SM12,SM14,SSK1,SSK2,SSK3,SSX2,SSX4,STP,STS,SW2,SXS4,VEX,VEX7	
			1	-	-	-	2249341 LTA	
			1	-	-	-	3475742 SKR	
			1	-	-	-	2077061 QXG	
	18340-ZH7-U20	.....	1	(1)	-	-	QJG2,QXG2	
			1	-	-	-	2077062 QXG	
6	18355-ZE1-000	ARRESTER, SPARK .....	1	-	-	-	QA,QAA2,QA2,QA26,QMX2,QTC2,QX7,RHC,SMW2,SM12,SSK1,SSK2,SSK3,SSX2,SSX4,SX7,VA,VED1,VED6,VEX7,VX7,WD12,WKD6,WKT2,WKT4,WKT6,WME2	
			1	-	-	-	3904653 SXS4	
			(1)	-	-	-	HTF2,HT2,HX,HXQ,HXU,HX2,HX26,HX4,QJG2,QJW1,QLL,QX,QXG,QXG2,QXQ,QXS,QXS2,QXU,QX2,QX26,QX4,SWX2,SWX4,TX,TX2,TX26,TX4	
			-	(1)	-	-		



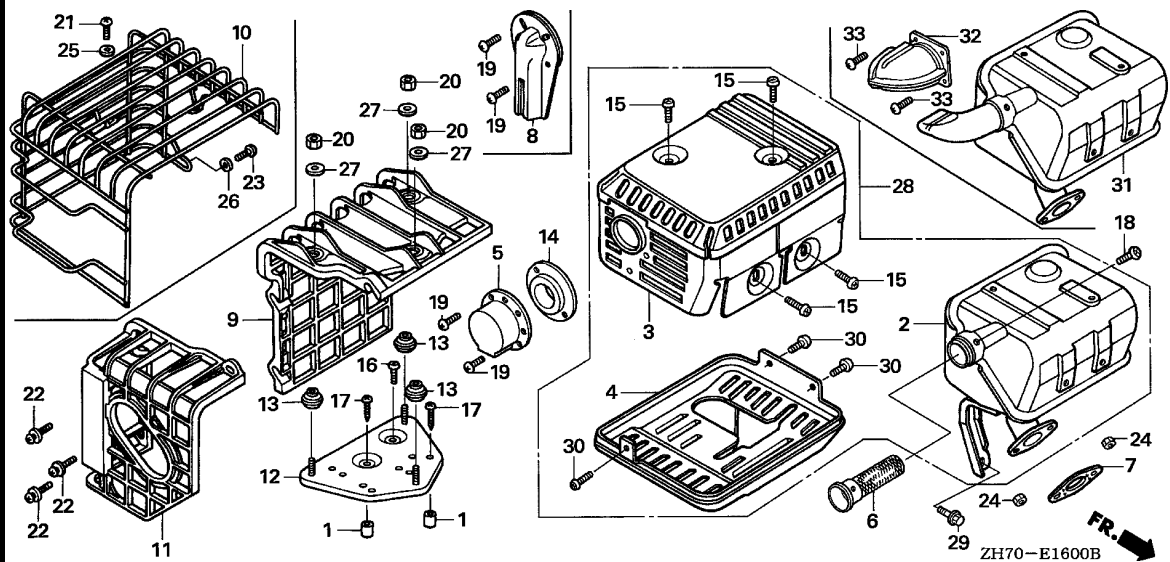

Ref. No.	Part No.	Description	Reqd. QTY				Serial No.	Parts catalogue code
			(1)	(2)	(3)	(4)		
7	18381-ZH8-000	GASKET, MUFFLER	1	-	-	-	2157159 DS,EN,ET,ETX,LJ,LW2,PM,PM2,QM,QSJ,QT,SJ,SMJ,SN,STS,SW2,VET,WJ	
	18381-ZH8-800		-	(1)	-	-	2157159 HH,HHQ4,HTF2,HT2,HX,HXQ,HXU,HX2,HX26,HX4,LAJ4,LD,LDB1,LDB3,LD4,LEH4,LH,LHQ4,LJC,LJD2,LJS,LJT,LSJ,LSJ4,LTA,LTJ,LTJ1,LTR,LTS,LX,LXU,LX2,LX26,LX4,PH,PX,PX2,QA,QAA2,QA2,QA26,QB26,QD,QEH,QH,QHQ4,QH2,QH26,QJG2,QJW1,QLL,QMA4,QME4,QMH,QMX2,QPU,QTC2,QX,QXG,QXG2,QXQ,QXS,QXS2,QXU,QX2,QX26,QX4,QX7,RD,RD4,RH,RHC,RHQ4,RX,RX4,SAJ,SAJ4,SCJ,SD,SDB1,SDB3,SD16,SD4,SH,SHQ4,SJC,SJC1,SJC5,SKJ,SKR,SMW2,SM11,SM12,SM14,SSK1,SSK2,SSK3,SSX2,SSX4,STP,SWX2,SWX4,SX,SXS4,SX4,SX7,TH,TX,TX2,TX26,TX4,UH,UX,UXU,VA,VAX4,VED,VED1,VED6,VEK,VEX,VEX7,VH,VS,VS1,VX,VXU,VX4,VX7,WDA6,WDJ,WD12,WJP,WJP1,WJ1,WKD6,WKT2,WKT4,WKT6,WMA3,WME2,WME4,WM1	
			1	-	-	-	2157160 DS,EN,ET,ETX,LJ,LW2,PM,PM2,QM,QSJ,QT,SJ,SMJ,SN,STS,SW2,VET,WJ	
			-	(1)	-	-	2157160	
8	18431-ZH8-W50	DEFLECTOR, MUFFLER	(1)	-	-	-	LEH4,QEH,QLL,QMA4,QPU,SXS4,VEX,VEX7,WDA6,WD12,WMA3,WME4,WM1	
9	18433-ZH8-W40	COVER COMP., MUFFLER	(1)	-	-	-	HHQ4,HX4,LAJ4,LD4,LEH4,LHQ4,LSJ4,LX4,QEH,QHQ4,QLL,QMA4,QME4,QPU,QX4,QX7,RD4,RHQ4,RX4,SAJ4,SD4,SHQ4,SXS4,SX4,SX7,TX4,VEX,VEX7,VX4,VX7,WDA6,WD12,WKT4,WMA3,WM1	
10	18433-ZH8-W60	COVER, MUFFLER	(1)	-	-	-	LEH4,QEH,QPU	
11	18434-ZH8-W40	COVER COMP., MUFFLER RR.	(1)	-	-	-	HHQ4,HX4,LAJ4,LD4,LEH4,LHQ4,LSJ4,LX4,QEH,QHQ4,QLL,QMA4,QME4,QPU,QX4,QX7,RD4,RHQ4,RX4,SAJ4,SD4,SHQ4,SXS4,SX4,SX7,TX4,VEX,VEX7,VX4,VX7,WDA6,WD12,WKT4,WMA3,WM1	
12	18436-ZH8-W40	BASE COMP., MUFFLER COVER	(1)	-	-	-	HHQ4,HX4,LAJ4,LD4,LEH4,LHQ4,LSJ4,LX4,QEH,QHQ4,QLL,QMA4,QME4,QPU,QX4,QX7,RD4,RHQ4,RX4,SAJ4,SD4,SHQ4,SXS4,SX4,SX7,TX4,VEX,VEX7,VX4,VX7,WDA6,WD12,WKT4,WMA3,WM1	

Ref. No.	Part No.	Description	Reqd. QTY			Serial No.	Parts catalogue code
			(1)	GX120K1 (2)	(3)		
13	18466-ZH8-W40	SPACER, MUFFLER COVER .....	(3)	-	-	-	HHQ4, HX4, LAJ4, LD4, LEH4, LHQ4, LSJ4, LX4, QEH, QHQ4, QLL, QMA4, QME4, QPU, QX4, QX7, RD4, RHQ4, RX4, SAJ4, SD4, SHQ4, SXS4, SX4, SX7, TX4, VEX, VEX7, VX4, VX7, WDA6, WD12, WKT4, WMA3, WM1
14	18522-ZE1-000	GUIDE, MUFFLER .....	1	-	1	-	HTF2, LAJ4, LEH4, LJD2, LJS, LJT, LSJ, LSJ4, LTJ, LTK1, LTR, LW2, QA, QAA2, QA2, QA26, QEH, QIH1, QJW1, QLL, QMA4, QMH, QMX2, QPU, QT, QTC2, SAJ, SAJ4, SCJ, SJC1, SJC5, SMW2, SM11, SM12, SM14, SSK1, SSK2, SSK3, SSX2, SSX4, STP, STS, SW2, SXS4, VEX, VEX7
			1	-	-	2249341	LTA
			1	-	-	2555265	SJC
			1	-	-	3475742	SKR
			-	(1)	-	-	-
15	90050-ZE1-000	SCREW, TAPPING, 5X8 .....	4	-	-	-	DS, EN, ET, ETX, HH, HHQ4, HTF2, HT2, HX, HXQ, HXU, HX2, HX26, HX4, LAJ4, LD, LDB1, LDB3, LD4, LEH4, LH, LHQ4, LJ, LJC, LJD2, LJS, LJT, LSJ, LSJ4, LTA, LTJ, LTK1, LTR, LTS, LW2, LX, LXU, LX2, LX26, LX4, PH, PM, PM2, PX, PX2, QA, QAA2, QA2, QA26, QD, QEH, QH, QHQ4, QH2, QH26, QJG2, QJW1, QLL, QM, QMA4, QME4, QMH, QMX2, QPU, QSJ, QT, QTC2, QX, QXG, QXG2, QXQ, QXS, QXS2, QXU, QX2, QX26, QX4, QX7, RD, RD4, RH, RHC, RHQ4, RX, RX4, SAJ, SAJ4, SCJ, SD, SDB1, SDB3, SD16, SD4, SH, SHQ4, SJ, SJC, SJC1, SJC5, SKJ, SKR, SMJ, SMW2, SM11, SM12, SM14, SN, SSK1, SSK2, SSK3, SSX2, SSX4, STP, STS, SWX2, SWX4, SW2, SXS4, SX4, SX7, TH, TX, TX2, TX26, TX4, UH, UX, UXU, VA, VED, VED1, VED6, VEK, VET, VEX, VEX7, VH, VS, VS1, VX, VXU, VX4, VX7, WDA6, WDJ, WD12, WJ, WJP, WJP1, WJ1, WKD6, WKT2, WKT4, WKT6, WMA3, WME2, WME4, WM1
			4	-	-	3230227	QB26
			-	(4)	4	4	-
16	90050-ZE1-000	SCREW, TAPPING, 5X8 .....	(1)	-	-	-	HHQ4, HX4, LAJ4, LD4, LHQ4, LSJ4, LX4, QHQ4, QMA4, QX4, QX7, RD4, RHQ4, RX4, SAJ4, SD4, SHQ4, SXS4, SX4, SX7, TX4, VEX7, VX4, VX7, WDA6, WD12, WMA3, WM1
17	90050-ZH8-W40	SCREW, TAPPING, 5X25 .....	(2)	-	-	-	HHQ4, HX4, LAJ4, LD4, LEH4, LHQ4, LSJ4, LX4, QEH, QHQ4, QLL, QMA4, QME4, QPU, QX4, QX7, RD4, RHQ4, RX4, SAJ4, SD4, SHQ4, SXS4, SX4, SX7, TX4, VEX, VEX7, VX4, VX7, WDA6, WD12, WKT4, WMA3, WM1
18	90055-ZE1-000	SCREW, TAPPING, 4X6 .....	1	-	-	-	QA, QAA2, QA2, QA26, QMX2, QTC2, QX7, RHC, SMW2, SM12, SSK1, SSK2, SSK3, SSX2, SSX4, SX7, VA, VED1, VED6, VEX7, VX7, WD12, WKD6, WKT2, WKT4, WKT6, WME2
			1	-	-	3904653	SXS4
			(1)	-	-	-	HTF2, HT2, HX, HXQ, HXU, HX2, HX26, HX4, QJG2, QJW1, QLL, QX, QXG, QXG2, QXQ, QXS, QXS2, QXU, QX2, QX26, QX4, SWX2, SWX4, TX, TX2, TX26, TX4
			-	(1)	-	-	-
19	90055-ZE1-000	SCREW, TAPPING, 4X6 .....	1	-	-	3904653	SXS4
			2	-	-	-	LEH4, QJG2, QXG, QXG2
			2	-	-	2288495	LW2, QA, QA2, QEH, QT, STS, SW2
			3	-	-	-	LTS
			(2)	-	-	-	QMA4, VEX7, WDA6, WD12, WMA3, WME4, WM1
			-	(2)	-	2288495	-
90002-ZG0-003	SCREW, TAPPING, 4X8 .....	2	-	2	-	-	HTF2, LAJ4, LJD2, LJS, LJT, LSJ, LSJ4, LTJ, LTK1, LTR, QAA2, QA26, QIH1, QJW1, QLL, QMA4, QMH, QMX2, QPU, QTC2, SAJ, SAJ4, SCJ, SJC, SJC1, SJC5, SMW2, SM11, SM12, SM14, SSK1, SSK2, SSK3, SSX2, SSX4, STP, SXS4, VEX, VEX7
			2	-	-	2249341	LTA
			2	-	-	2288496	LW2, QA, QA2, QEH, QT, STS, SW2
			2	-	-	3475742	SKR
			-	(2)	-	2288496	-
20	90302-KF9-900	NUT, HEX., 5MM .....	(3)	-	-	-	HHQ4, HX4, LAJ4, LD4, LEH4, LHQ4, LSJ4, LX4, QEH, QHQ4, QLL, QMA4, QME4, QPU, QX4, QX7, RD4, RHQ4, RX4, SAJ4, SD4, SHQ4, SXS4, SX4, SX7, TX4, VEX, VEX7, VX4, VX7, WDA6, WD12, WKT4, WMA3, WM1
21	93500-05010-0A	SCREW, PAN, 5X10 .....	(2)	-	-	-	LEH4, QEH, QPU
22	93891-06020-07	SCREW-WASHER, 6X20 .....	(3)	-	-	-	HHQ4, HX4, LAJ4, LD4, LEH4, LHQ4, LSJ4, LX4, QEH, QHQ4, QLL, QMA4, QME4, QPU, QX4, QX7, RD4, RHQ4, RX4, SAJ4, SD4, SHQ4, SXS4, SX4, SX7, TX4, VEX, VEX7, VX4, VX7, WDA6, WD12, WKT4, WMA3, WM1



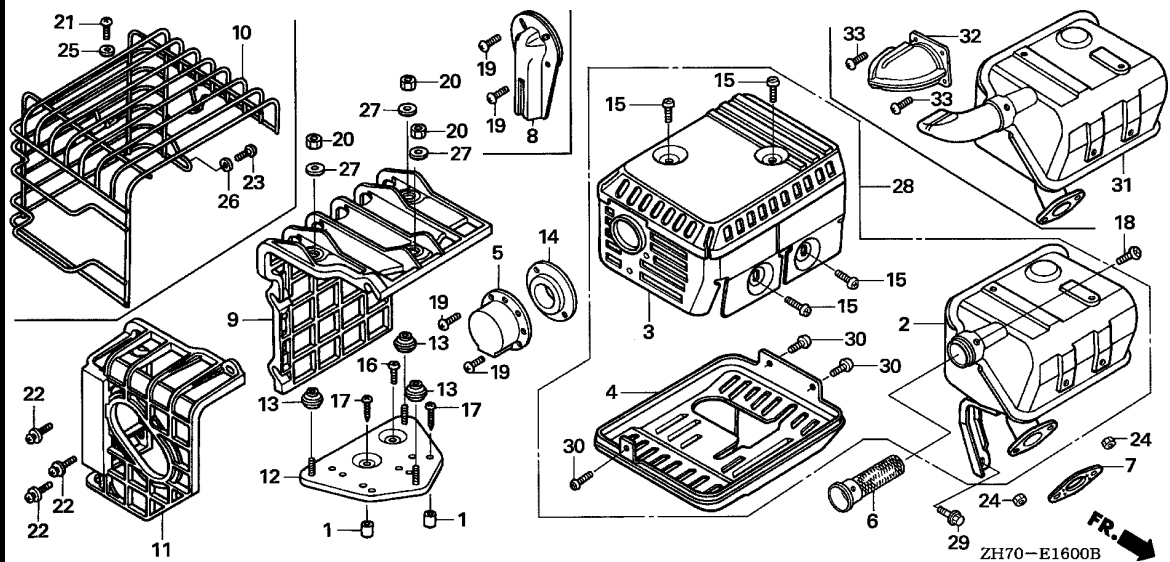

Ref. No.	Part No.	Description	Reqd. QTY				Serial No.	Parts catalogue code
			(1)	(2)	(3)	(4)		
23	93901-26280	SCREW, TAPPING, 6X16	(1)	-	-	-	-----	LEH4, QEH, QPU
24	94001-08000-0S	NUT, HEX., 8MM	2	-	-	-	-----	DS, EN, ET, ETX, HH, HHQ4, HTF2, HT2, HX, HXQ, HXU, HX2, HX26, HX4, LAJ4, LD, LDB1, LDB3, LD4, LEH4, LH, LHQ4, LJ, LJC, LJD2, LJS, LJT, LSJ, LSJ4, LTA, LTJ, LTK1, LTR, LTS, LW2, LX, LXU, LX2, LX26, LX4, PH, PM, PM2, PX, PX2, QA, QAA2, QA2, QA26, QB26, QD, QEH, QH, QHQ4, QH2, QH26, QJG2, QJW1, QLL, QM, QMA4, QME4, QMH, QMX2, QPU, QSJ, QT, QTC2, QX, QXG, QXG2, QXQ, QXS, QXS2, QXU, QX2, QX26, QX4, QX7, RD, RD4, RH, RHC, RHQ4, RX, RX4, SAJ, SAJ4, SCJ, SD, SDB1, SDB3, SD16, SD4, SH, SHQ4, SJ, SJC, SJC1, SJC5, SKJ, SKR, SMJ, SMW2, SM11, SM12, SM14, SN, SSK1, SSK2, SSK3, SSS2, SSS4, SWX2, SWX4, SW2, SX, SXS4, SX4, SX7, TH, TX, TX2, TX26, TX4, UH, UX, UXU, VA, VED, VED1, VED6, VEK, VET, VEX, VEX7, VH, VS, VS1, VX, VXU, VX4, VX7, WDA6, WDJ, WD12, WJ, WJP, WJP1, WJ1, WKD6, WKT2, WKT4, WKT6, WMA3, WME2, WME4, WM1
			2	-	-	-	-----	2119399 STS
	90136-MT4-000	NUT, FLANGE, 8MM	2	2	2	2	-----	STP
25	94101-05000	WASHER, PLAIN, 5MM	2	-	-	-	2119400	-----
			(2)	-	-	-	-----	LEH4, QEH, QPU
26	94101-06000	WASHER, PLAIN, 6MM	(1)	-	-	-	-----	LEH4, QEH, QPU
27	94103-05700	WASHER, PLAIN, 5MM	(3)	-	-	-	-----	HHQ4, HX4, LAJ4, LD4, LEH4, LHQ4, LSJ4, LX4, QEH, QHQ4, QLL, QMA4, QME4, QPU, QX4, QX7, RD4, RHQ4, RX4, SAJ4, SD4, SHQ4, SXS4, SX4, SX7, TX4, VEX, VEX7, VX4, VX7, WDA6, WD12, WKT4, WMA3, WM1
28	18300-ZH8-840	MUFFLER ASSY. (LOWER PROTECTOR)	1	-	-	-	-----	LTK1, SJC1
29	90016-ZE1-000	BOLT, FLANGE, 6X13(CT200)	1	-	-	-	-----	SM11, SM12, SM14
	95701-06012-00	BOLT, FLANGE, 6X12	1	-	-	-	2249341	-----
			1	-	-	-	-----	LTA
			1	-	-	-	-----	SJC1

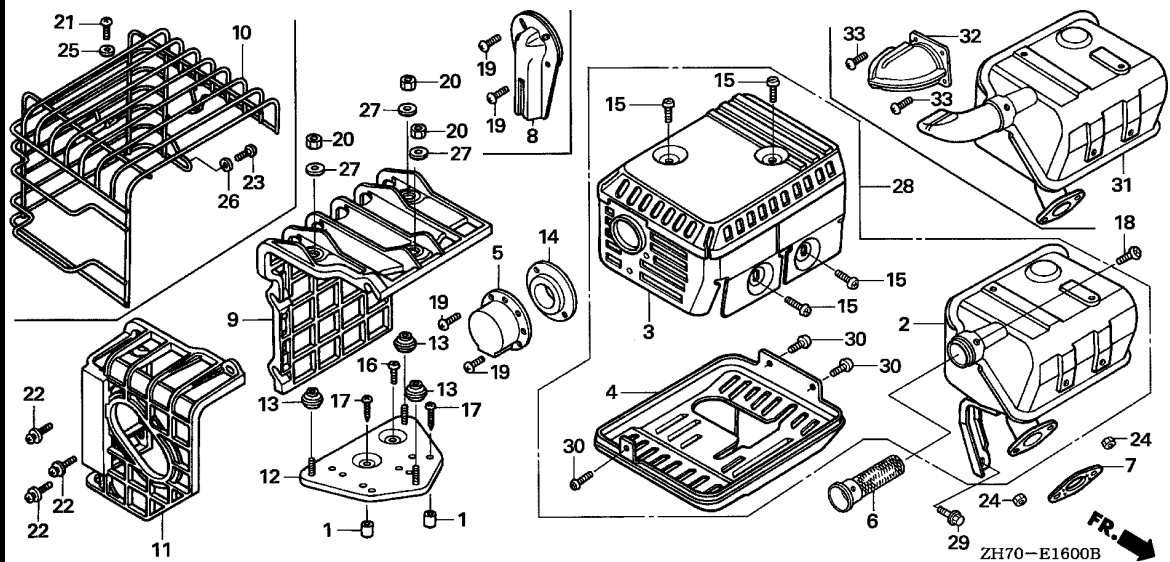

Ref. No.	Part No.	Description	Reqd. QTY				Serial No.	Parts catalogue code
			(1)	(2)	(3)	(4)		
			GX120K1					
30	90055-ZE1-000	SCREW, TAPPING, 4X6	1	-	-	-	3904653	SXS4
			3	-	-	-		DS,LJ,LJC,LJS,LJT,LSJ,LTJ,LTK1,LTR,LTS,QSJ,QXS,QXS2,SAJ,SCJ,SJ
			3	-	-	-	2119399	STC,SJC1,SJC5,SKJ,SKR,SMJ,VEK,VET,WJ,WJP,WJP1
			-	(3)	-	-		
31	18310-ZE0-A20	MUFFLER COMP.	1	-	-	-		VEK
32	18340-ZE0-A60	PROTECTOR, TAIL PIPE	1	-	-	-		VEK
33	90055-ZE1-000	SCREW, TAPPING, 4X6	2	-	-	-		VEK





# E-16-1

# MUFFLER(2)

J16

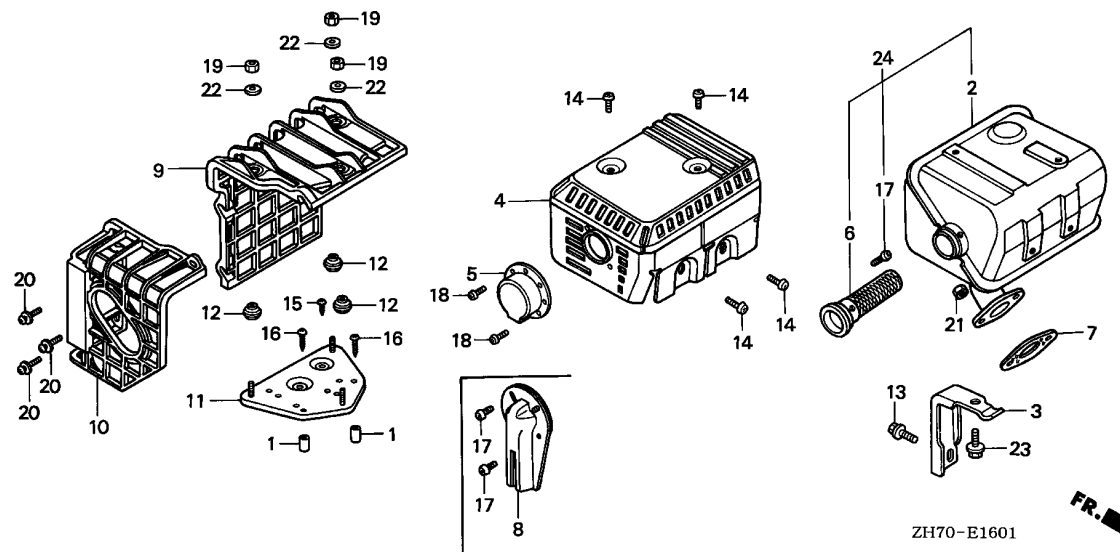

Ref. No.	L.O.N.	(Relative ref. Number) Description	F.R.T.
2	3131C5	MUFFLER, EXHAUST .....	0.2
4	3131D9	PROTECTOR, EXHAUST MUFFLER : OUTER .....	0.2
6	3131A1	ARRESTER, SPARK .....	0.2
7	3131B4	GASKET, EXHAUST MUFFLER .....	0.2
9	3131A7	COVER, EXHAUST MUFFLER .....	0.1
10	3131A6	COVER, EXHAUST MUFFLER : REAR ..	0.1
11	3131A2	BASE, EXHAUST MUFFLER COVER ..	0.2

Ref. No.	Part No.	Description	Reqd. QTY				Serial No.	Parts catalogue code
			(1)	(2)	(3)	(4)		
1	17233-896-701	COLLAR, AIR CLEANER CASE .....	(2)	-	-	-	QE,QMA8,QWA4,SE,SG24,SMA7,VMS4	
2	18310-ZE1-821	MUFFLER COMP. (SILENT) .....	1	-	-	-	LE,QBU2,QE,QMA8,QWA4,QXC9,SAD2,SE,SG24,SJD2,SMA7,VEE1,VMS4,VSX,VSX1	
3	18315-ZE1-000	STAY, MUFFLER .....	1	(1)	-	-	LE,QBU2,QE,QMA8,QWA4,QXC,QXC9,SAD2,SE,SG24,SJD2,SMA7,VEE1,VMS4,VSX,VSX1	
4	18321-ZH8-820	PROTECTOR, MUFFLER OUTER (SILENT) .....	1	(1)	-	-	2030018 LE,QE,QXC,SE 2030018	
	18320-ZF1-H50	PROTECTOR, MUFFLER (SILENT) ..	1	-	-	-	3468948 VSX,VSX1 2030019 2504429 QXC 2030019 3468948 LE,QE,SE 2030019 H1,L1,R1,U1,V1,W1 2030019 2468948 Q1,S1	
	18320-ZF1-H51	.....	1	-	-	-	QBU2,QMA8,QWA4,QXC9,SAD2,SG24,SJD2,SMA7,VEE1,VMS4 2504430 QXC 3468949 LE,QE,SE,VSX,VSX1 2468949 Q1,S1	
5	18331-883-810	CAP, MUFFLER .....	1	-	-	-	QBU2,QMA8,QWA4,QXC,QXC9,SAD2,SG24,SJD2,SMA7,VMS4 3093870 VEE1	
6	18355-ZE1-810	ARRESTER, SPARK (SILENT) .....	1	-	-	-	LE,QBU2,QE,QMA8,QWA4,QXC,QXC9,SAD2,SE,SG24,SJD2,SMA7,VEE1,VMS4,VSX,VSX1 2816331	
7	18381-ZH8-800	GASKET, MUFFLER .....	1	-	-	-	LE,QBU2,QE,QMA8,QWA4,QXC,QXC9,SAD2,SE,SG24,SJD2,SMA7,VEE1,VMS4,VSX,VSX1	

2

E-16-1

MUFFLER(2)



Ref. No.	Part No.	Description	Reqd. QTY				Serial No.	Parts catalogue code
			(1)	GX120K1 (2)	(3)	(4)		
8	18431-ZH8-W50	DEFLECTOR, MUFFLER .....	(1)	-	-	-	QMA8,QWA4,SG24,SMA7,VMS4	
9	18433-ZH8-W40	COVER COMP., MUFFLER .....	(1)	-	-	-	QE,QMA8,QWA4,SE,SG24,SMA7,VMS4	
10	18434-ZH8-W40	COVER COMP., MUFFLER RR. ....	(1)	-	-	-	QE,QMA8,QWA4,SE,SG24,SMA7,VMS4	
11	18436-ZH8-W40	BASE COMP., MUFFLER COVER ...	(1)	-	-	-	QE,QMA8,QWA4,SE,SG24,SMA7,VMS4	
12	18466-ZH8-W40	SPACER, MUFFLER COVER .....	(3)	-	-	-	QE,QMA8,QWA4,SE,SG24,SMA7,VMS4	
13	90016-ZE1-000	BOLT, FLANGE, 6X13(CT200) ...	1	-	-	-	LE,QBU2,QE,QMA8,QWA4,QXC9,SAD2,SE,SG24,SJD2,SMA7,VEE1,VMS4,VSX1	
			1	-	-	2299936	QXC	
14	90050-ZE1-000	SCREW, TAPPING, 5X8 .....	4	-	-	-	LE,QBU2,QE,QMA8,QWA4,QXC,QXC9,SAD2,SE,SG24,SJD2,SMA7,VEE1,VMS4	
			4	-	-	2816331	VSX,VSX1	
	90050-ZE3-H00	.....	4	-	-	2816332	VSX,VSX1	
15	90050-ZE1-000	SCREW, TAPPING, 5X8 .....	1	-	-	-	QWA4,VMS4	
			(1)	-	-	-	QE,QMA8,SE,SG24,SMA7	
16	90050-ZH8-W40	SCREW, TAPPING, 5X25 .....	(2)	-	-	-	QE,QMA8,QWA4,SE,SG24,SMA7,VMS4	
17	90055-ZE1-000	SCREW, TAPPING, 4X6 .....	1	(1)	-	-	H1,LE,L1,QBU2,QE,QXC,R1,SAD2,S1,U1,V1,W1	
			1	-	-	2816331	VSX,VSX1	
	90056-ZL0-000	.....	1	(1)	-	-	QMA8,QWA4,QXC9,Q1,SE,SG24,SJD2,SMA7,VEE1,VMS4	
	90055-ZE1-000	.....	(2)	-	-	-	QMA8,QWA4,SG24,SMA7,VMS4	
18	90055-ZE1-000	SCREW, TAPPING, 4X6 .....	2	-	-	-	QBU2,QMA8,QWA4,QXC,QXC9,SAD2,SG24,SJD2,SMA7,VMS4	
			2	-	-	3093870	VEE1	
			-	(2)	-	-	2288495	
	90002-ZG0-003	SCREW, TAPPING, 4X8 .....	-	(2)	-	2288496		
19	90302-KF9-900	NUT, HEX., 5MM .....	(3)	-	-	-	QE,QMA8,QWA4,SE,SG24,SMA7,VMS4	
20	93891-06020-07	SCREW-WASHER, 6X20 .....	(3)	-	-	-	QE,QMA8,QWA4,SE,SG24,SMA7,VMS4	
21	94001-08000-0S	NUT, HEX., 8MM .....	2	-	-	-	LE,QBU2,QE,QMA8,QWA4,QXC,QXC9,SAD2,SE,SG24,SJD2,SMA7,VEE1,VMS4	
			-	2	-	-	VSX,VSX1	
22	94103-05700	WASHER, PLAIN, 5MM .....	(3)	-	-	-	QE,QMA8,QWA4,SE,SG24,SMA7,VMS4	
23	95900-06012-00	BOLT, FLANGE, 6X12 .....	1	(1)	-	2468948	H1,LE,L1,QE,Q1,R1,SE,S1,VSX,VSX1,V1,W1	
			1	-	-	2504429	QXC	
			-	(1)	-	-	U1	
	95701-06012-00	.....	1	(1)	-	2468949	H1,LE,L1,QE,Q1,R1,SE,S1,VSX,VSX1,V1,W1	
			1	-	-	-	QBU2,QMA8,QWA4,QXC9,SAD2,SG24,SJD2,SMA7,VEE1,VMS4	
			1	-	-	2504430	QXC	
24	183A1-ZE1-821	MUFFLER COMP. (SILENT) .....	1	-	-	-	QXC	



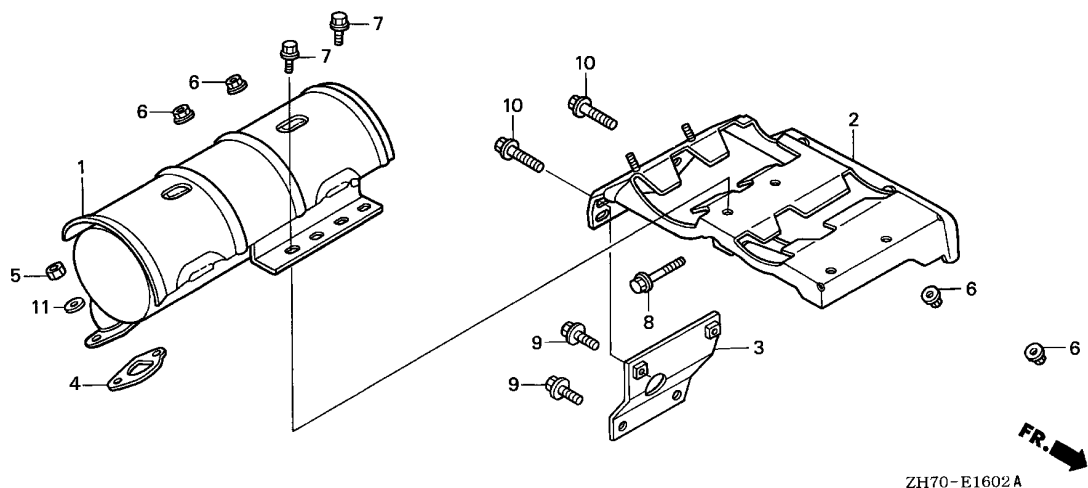

ZH70-E1602A

Ref. No.	L.O.N.	(Relative ref. Number) Description	F.R.T.
1	3131C5	MUFFLER, EXHAUST .....	0.2
2	3131E1	STAY, MUFFLER .....	0.3
4	3131B4	GASKET, EXHAUST MUFFLER .....	0.2

2

Ref. No.	Part No.	Description	Reqd. QTY				Serial No.	Parts catalogue code
			(1)	(2)	(3)	(4)		
			GX120K1					
1	18310-ZK7-V01	MUFFLER COMP. ....	1	-	-	-	AR,DKR,KR,KRA4,KRF4,KRS4,KRT,KRT4,KRT6	
2	18338-ZK7-V00	STAY COMP., MUFFLER .....	1	-	-	-	AR,DKR,KR,KRA4,KRF4,KRS4,KRT,KRT4,KRT6	
3	18338-ZK7-V20	STAY COMP., MUFFLER .....	1	-	-	-	KRT,KRT4,KRT6	
4	18381-ZH8-800	GASKET, MUFFLER .....	1	-	-	-	AR,DKR,KR,KRA4,KRF4,KRS4,KRT,KRT4,KRT6	
5	94001-08000-0S	NUT, HEX., 8MM .....	2	-	-	-	AR,DKR,KR,KRA4,KRF4,KRS4,KRT,KRT4,KRT6	
6	94050-06000	NUT, FLANGE, 6MM .....	4	-	-	-	AR,DKR,KR,KRA4,KRF4,KRS4,KRT,KRT4,KRT6	
7	95701-06016-00	BOLT, FLANGE, 6X16 .....	2	-	-	-	AR,DKR,KR,KRA4,KRF4,KRS4,KRT,KRT4,KRT6	
8	95701-06025-00	BOLT, FLANGE, 6X25 .....	1	-	-	-	AR,DKR,KR,KRA4,KRF4,KRS4,KRT,KRT4,KRT6	
9	95701-08012-00	BOLT, FLANGE, 8X12 .....	2	-	-	-	KRT,KRT4,KRT6	
10	95701-08018-00	BOLT, FLANGE, 8X18 .....	2	-	-	-	KRT,KRT4,KRT6	
	95701-08020-00	BOLT, FLANGE, 8X20 .....	2	-	-	-	AR,DKR,KR,KRA4,KRF4,KRS4	
11	94103-08700	WASHER, PLAIN, 8MM .....	2	-	-	-	KRS4	

E-16-3

MUFFLER(4)

K 3

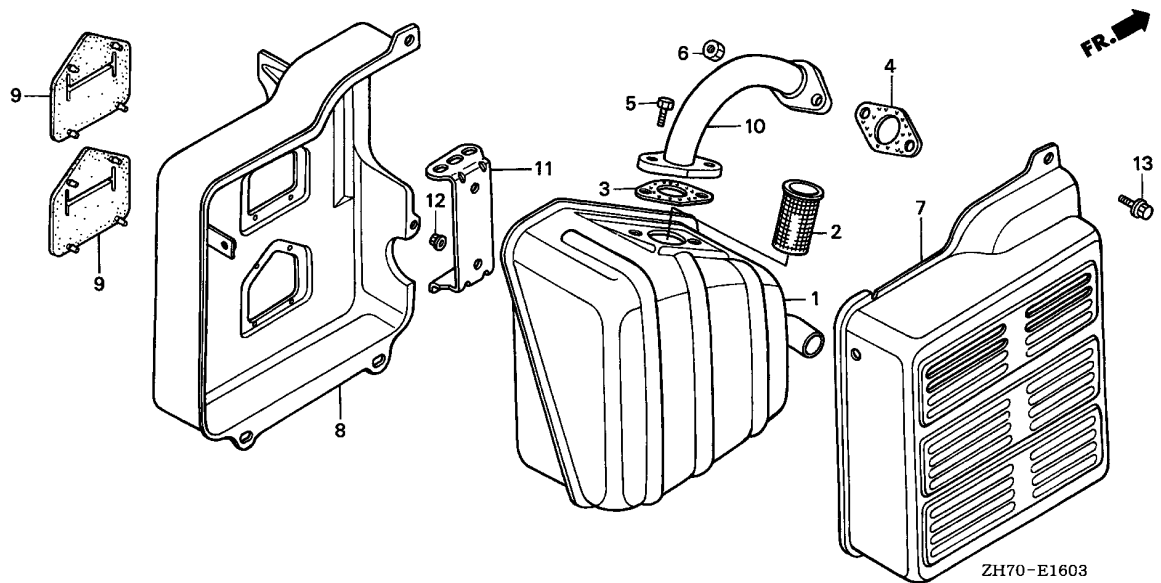

Ref. No.	L.O.N.	(Relative ref. Number) Description	F.R.T.
1	3131C5	MUFFLER, EXHAUST .....	0.2
2	3131A1	ARRESTER, SPARK .....	0.2
3	3131B4	GASKET, EXHAUST MUFFLER .....	0.2
4	3131B4	GASKET, EXHAUST MUFFLER .....	0.2
7	3131D9	PROTECTOR, EXHAUST MUFFLER : OUTER .....	0.2
8	3131D8	PROTECTOR, EXHAUST MUFFLER : INNER .....	0.2
9	3131G6	SEAL, MUFFLER PROTECTOR .....	0.2

Ref. No.	Part No.	Description	Reqd. QTY				Serial No.	Parts catalogue code
			(1)	(2)	(3)	(4)		
1	18310-ZB3-C00	MUFFLER COMP. ....	1	-	-	-	VMT,VPR4	
2	18355-898-630	ARRESTER, SPARK .....	1	-	-	-	VPR4	
3	18381-ZE1-800	GASKET, MUFFLER .....	1	-	-	-	VMT,VPR4	
4	18381-ZH8-800	GASKET, MUFFLER .....	1	-	-	-	VMT,VPR4	
5	92101-08020-0A	BOLT, HEX., 8X20 .....	2	-	-	-	VMT,VPR4	
6	94001-08000-0S	NUT, HEX., 8MM .....	2	-	-	-	VMT,VPR4	
7	18320-ZB2-000	PROTECTOR, MUFFLER OUTER .....	1	-	-	-	VMT	
8	18325-ZB2-000	PROTECTOR, MUFFLER INNER .....	1	-	-	-	VMT	
9	18329-ZB2-000	SEAL, MUFFLER PROTECTOR .....	2	-	-	-	VMT	
10	18330-ZB2-000	PIPE COMP., EX. ....	1	-	-	-	VMT	
11	18338-ZB3-E30	STAY, MUFFLER .....	1	-	-	-	VMT	
12	94050-06000	NUT, FLANGE, 6MM .....	2	-	-	-	VMT	
13	95701-06012-00	BOLT, FLANGE, 6X12 .....	5	-	-	-	VMT	

2

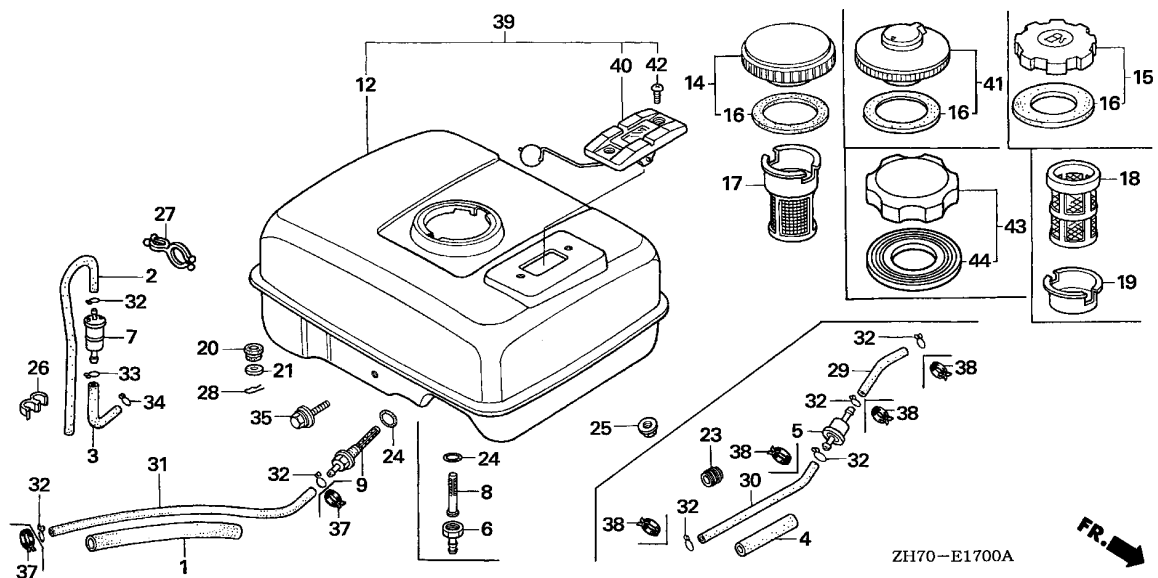

Ref. No.	L.O.N.	(Relative ref. Number) Description	F.R.T.
3	3101G0	TUBE, FUEL STRAINER .....	0.1
7		(5)	
	3101H8	STRAINER, FUEL .....	0.1
8	3101D5	SCREEN, FUEL STRAINER .....	0.2
9	3101H6	STRAINER, JOINT FUEL .....	0.2
12	3101H7	TANK, FUEL .....	0.2
17		(18)	
	3101A6	FILTER, FUEL .....	0.1
31	3101F1	TUBE, FUEL TANK .....	0.2
40	6171A1	METER UNIT, FUEL .....	0.1

Ref. No.	Part No.	Description	Reqd. QTY				Serial No.	Parts catalogue code
			(1)	(2)	(3)	(4)		
1	16854-ZH8-000	RUBBER, SUPPORTER (107MM) ...	1	-	-	-	4091237	AR,DKR,DS,EN,ET,ETX,HH,HHQ4,HTF2,HT2,HX,HXQ,HXU,HX2,HX26,HX4 KR,KRA4,KRT,KRT4,KRT6,LAJ4,LD,LDB1,LDB3,LD4,LE,LEH4,LH,LHQ4,LJ LJC,LJD2,LJS,LJT,LSJ,LSJ4,LTA,LTJ, LTK1,LW2,LX,LXU,LX2,LX26,LX4 PH,PM,PM2,PX,PX2,QA,QA2,QA26,QBU2,QD,QE,QEH,QH,QHQ4,QH2 QH26,QJG2,QJW1,QLL,QM,QMA4,QMA8,QME4,QMH,QMX2,QPU,QSJ,QT,QTC2 QWA4,QX,QXC,QXC9,QXG,QXG2,QXQ,QXS,QXS2,QXU,QX2,QX26,QX4,QX7,RD RD4,RH,RHQ4,RX,RX4,SAD2,SAJ,SAJ4,SCJ,SD,SDB1,SDB3,SD16,SD4,SE SG24,SH,SHQ4,SJ,SJC,SJC1,SJC5,SJD2,SKJ,SMA7,SMJ,SMW2,SM11,SM12 SM14,SN,SSK1,SSK2,SSK3,SSX2,SSX4,STP,STS,SWX2,SWX4,SW2,SX,SXS4 SX4,SX7,TH,TX,TX2,TX26,TX4,UH,UX,UXU,VA,VED,VED1,VED6,VEE1,VEK VET,VEX,VEX7,VH,VMS4,VS,VSX,VSX1,VS1,VX,VXU,VX4,VX7,WDA6,WDJ WD12,WJ,WJP,WJP1,WKD6,WKT2,WKT4,WKT6,WMA3,WME2,WME4
			1	-	-	-	4091237	KRS4
2	16198-ZG0-U00	TUBE A, AIR VENT .....	1	(1)	1	1		AR,DKR,KR,KRA4,KRF4,KRT,KRT4,KRT6
3	16199-KCR-000	TUBE .....	1	-	-	-		AR,DKR,KR,KRA4,KRF4,KRT,KRT4,KRT6
4	16854-ZH8-810	RUBBER, SUPPORTER (50MM) ....	1	-	-	-		VPR4
			1	-	-	-	4091238	KRS4
5	16910-GB2-005	STRAINER COMP., FUEL .....	1	-	-	-		AR,KRA4,VPR4
			1	-	-	-	3284617	KRT4
			1	-	-	-	4091238	KRS4
6	16950-732-000	JOINT, FUEL .....	1	-	-	-		EN,ET,ETX
7	16910-ZG0-U01	STRAINER COMP., FUEL .....	1	-	-	-	3514171	AR,DKR,KR,KRA4,KRT,KRT4,KRT6
	16910-ZG0-U02	.....	1	-	-	-		KRF4
			1	-	-	-	3514172	AR,DKR,KR,KRA4,KRT,KRT4,KRT6
8	16952-883-005	SCREEN SET .....	1	-	-	-		EN,ET,ETX

Ref. No.	Part No.	Description	Reqd. QTY				Serial No.	Parts catalogue code
			(1)	(2)	(3)	(4)		
9	16955-ZE1-000	JOINT, FUEL TANK .....	1	-	-	-	DS,HH,HHQ4,HTF2,HT2,HX,HXQ,HXU,HX2,HX26,HX4,LAJ4,LD,LDB1,LDB3,LD4,LE,LEH4,LH,LHQ4,LJ,LJC,LJD2,LJS,LJT,LSJ,LSJ4,LTA,LTJ,LTJ1,LW2,LX,LXU,LX2,LX26,LX4,PH,PM,PM2,PX,QA,QAA2,QA2,QA26,QBU2,QD,QE,QEH,QH,QHQ4,QH2,QH26,QJG2,QJW1,QLL,QM,QMA4,QMA8,QME4,QMH,QMX2,QPU,QSJ,QT,QTC2,QWA4,QX,QXC,QXC9,QXG,QXG2,QXQ,QXS,QXS2,QXU,QX2,QX26,QX4,QX7,RD,RH,RHQ4,RX,RX4,SAD2,SAJ,SAJ4,SCJ,SD,SDB1,SDB3,SD16,SD4,SE,SG24,SH,SHQ4,SJ,SJC,SJC1,SJC5,SJD2,SKJ,SKR,SMA7,SMJ,SMW2,SM11,SM12,SM14,SN,SSK1,SSK2,SSK3,SSX2,SSX4,STP,STS,SWX2,SWX4,SW2,SX,SXS4,SX4,SX7,TH,TX,TX2,TX26,TX4,UH,UX,UXU,VA,VED,VED1,VED6,VEE1,VEK,VET,VEX,VEX7,VH,VMS4,VS,VSX,VSX1,VS1,VX,VXU,VX4,VX7,WDA6,WDJ,WD12,WJ,WJP,WJP1,WKD6,WKT2,WKT4,WKT6,WMA3,WME2,WME4	
12	17510-ZE0-020ZA	TANK COMP., FUEL *NH31*.....MCKINLEY WHITE	1	(1)	1	1	DS,HH,HHQ4,HTF2,HT2,HX,HXQ,HXU,HX2,HX26,HX4,LAJ4,LD,LDB1,LDB3,LD4,LE,LH,LHQ4,LJ,LJC,LJS,LJT,LSJ,LSJ4,LTA,LTJ,LTJ1,LW2,LX,LXU,LX2,LX26,LX4,PH,PM,PM2,PX,QA,QAA2,QA2,QA26,QBU2,QD,QE,QH,QHQ4,QH2,QH26,QJW1,QLL,QM,QMA4,QMA8,QME4,QMH,QMX2,QPU,QSJ,QT,QTC2,QWA4,QX,QXC,QXC9,QXG,QXG2,QXQ,QXS,QXS2,QXU,QX2,QX26,QX4,QX7,RD,RD4,RH,RHQ4,RX,RX4,SAD2,SAJ,SAJ4,SCJ,SD,SDB1,SDB3,SD16,SD4,SE,SH,SHQ4,SJ,SJC,SJC1,SJC5,SMA7,SMW2,SN,STP,STS,SW2,SX,SXS4,SX4,SX7,TH,TX,TX2,TX26,TX4,UH,UX,UXU,VA,VED,VED1,VEE1,VEK,VET,VEX,VEX7,VH,VMS4,VS,VSX,VSX1,VX,VXU,VX4,VX7,WDA6,WDJ,WD12,WJ,WJP,WJP1,WKD6,WKT2,WKT4,WKT6,WMA3,WME2,WME4	
	17510-ZE0-020ZB	*R8*.....BRIGHT RED	1	(1)	-	1	LEH4,QEH,VS1	
	17510-ZE0-020ZD	*NH1*.....BLACK	1	-	-	-	4147626 VSX1	
	17510-ZE0-020ZE	*T51*.....JACOBSEN ORANGE	1	-	-	-	2242263 QX,TX	
	17510-ZE0-020ZG	*NH105*...MAT BLACK (#15-#20)	1	-	-	-	2243557 QXG2	
	17510-ZE0-020ZH	*Y131*.....LIGHTNING YELLOW	1	-	-	-	QXG	
	17510-ZE0-020ZJ	*T77*.....SEC WINE RED	1	-	-	-	SWX2,SWX4	
	17510-ZE0-020ZK	*T73*.....EXEN GRAY	1	-	-	-	VSX1	
	17510-ZF0-T00ZA	*NH31*.....MCKINLEY WHITE	1	-	-	-	VSX,VSX1	
	17510-ZH7-A20ZB	*NH111*.....CORTINA WHITE	1	-	-	-	VEE1	
	17510-ZH7-A20ZD	*NH31*.....MCKINLEY WHITE	1	-	-	-	SMJ	
	17510-ZK7-U20ZA	*NH105*...MAT BLACK (#15-#20)	1	-	-	-	SKJ,VEK	
	17510-ZK7-U20ZB	*T51*.....JACOBSEN ORANGE	1	-	-	-	LJD2,QJG2,SJD2	
	17510-ZE0-020ZL	*R280*.....POWER RED	1	-	-	-	4147627 QJG2	
14	17620-ZE2-W00	CAP COMP., FUEL FILLER (CHROME PLATED)	1	-	-	-	2421922 VSX1	
	17620-890-010	CAP COMP., FUEL FILLER .....	-	(1)	-	-	2421922	
	17620-ZE2-W00	CAP COMP., FUEL FILLER (CHROME PLATED)	1	-	-	-	LDB1,LDB3,SDB1,SDB3,VEE1	
			1	-	-	-	2533058 QT	
			-	-	1	1		



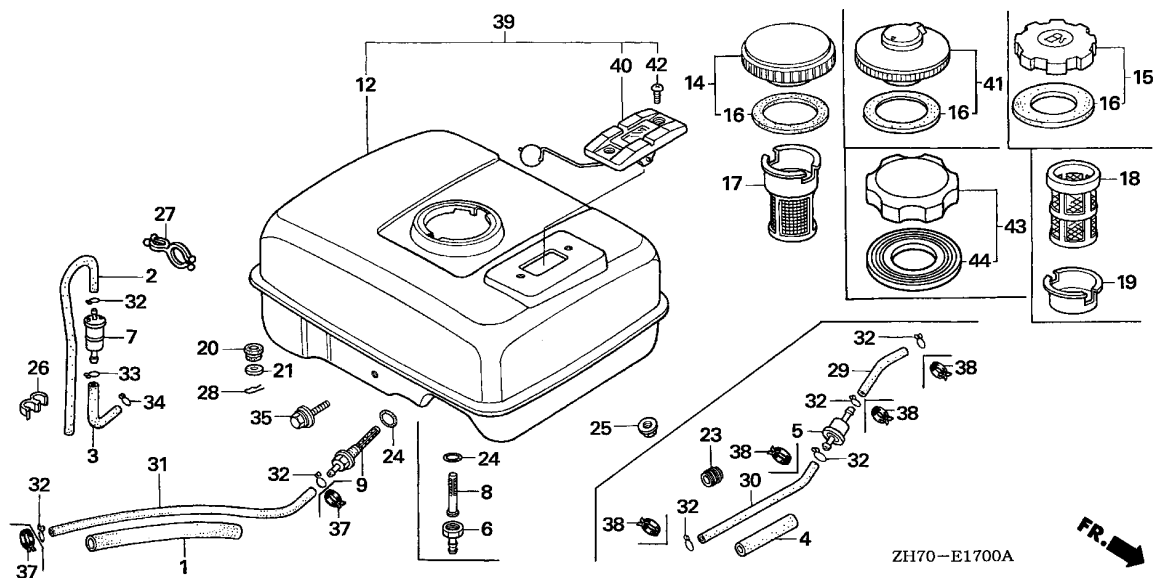

Ref. No.	Part No.	Description	Reqd. QTY				Serial No.		Parts catalogue code
			(1)	(2)	(3)	(4)	GX120K1		
15	17620-ZH7-013	CAP COMP., FUEL FILLER	1	(1)	-	-	2421923	3053130	DS,EN,ET,ETX,HH,HX,HXQ,HX2,H1,LD,LE,LH,LJ,LTJ,LW2,LX,LX2,L1,PH,PM,PM2,PX,QA,QA2,QD,QE,QEH,QH,QH2,QLL,QM,QPU,QSJ,QX,QXC,QXG,QXG2,QXQ,QXS,QXS2,QX2,Q1,RD,RH,RX,R1,SCJ,SD,SE,SH,SJ,SKJ,SMJ,SN,STS,SW2,SX,S1,TH,TX,TX2,UH,UX,VA,VED,VED1,VET,VEX,VH,VS,VSX,VSX1,VS1,VX,WJ,W1
			1	-	-	-	-----	3053130	HHQ4,HTF2,HX26,HX4,LD4,LEH4,LHQ4,LJD2,LSJ,LX26,LX4,PX2,QA2,QA26,QBU2,QHQ4,QH26,QJW1,QMA4,QMA8,QME4,QMH,QMX2,QT2,QXC9,QX26,QX4,RD4,RHQ4,RX4,SAD2,SAJ,SD16,SD4,SG24,SHQ4,SJC,SJC1,SJC5,SMA7,SMW2,SSK1,SSK2,SSK3,SSX4,STP, SX4, TX26, TX4, VX4, WDJ, WD12, WJP, WJP1, WKT2, WMA3, WME2
			1	-	-	-	2421923	2533057	QT
			-	(1)	-	-	2421923	-----	U1,V1
	17620-ZH7-023	CAP COMP., FUEL FILLER (BLACK)	1	(1)	-	-	3053131	-----	EN,ET,ETX,HH,HXQ,LD4,LE,LEH4,LW2,LX26,PH,PM,PM2,QA2,QA26,QBU2, QE,QEH,QH2,QJW1,QMH,QPU,QSJ,QT2,QXC,QXG,QXQ,QXS,RH,SAD2,SJC,SKJ,SN,SSK2,SW2,S1,TH,UH,UX,VA,VH,VS,VS1,WDJ,WJP1,W1
			1	(1)	-	-	3053131	4203082	DS,HHQ4,HTF2,HX,HX2,HX26,HX4,H1,LD,LH,LHQ4,LJ,LJD2,LSJ,LTJ,LX,LX2,LX4,L1,PX,PX2,QA,QA2,QD,QH,QHQ4,QH26,QLL,QM,QMA4,QMA8,QME4,QMX2,QX,QXC9,QXS2,QX2,QX26,QX4,Q1,RD,RD4,RHQ4,RX,RX4,R1,SAJ,SCJ,SD,SD16,SD4,SE,SG24,SH,SHQ4,SJ,SJC1,SJC5,SMA7,SMJ,SMW2,SSK1,SSK3,SSX4,STP,STS,SX,SX4,TX,TX2,TX26, TX4, VED, VED1, VET, VEX, VSX, VSX1, VX, VX4, WD12, WJ, WJP, WKT2, WMA3, WME2
			1	-	-	-	-----	-----	LJT
			1	-	-	-	-----	4203082	HT2,HXU,LAJ4,LJC,LJS,LSJ4,LTK1,LXU,QJG2,QWA4,QXU,QX7,SAJ4,SJD2,SKR,SM11,SM12,SM14,SSX2,SWX2,SWX4,SXS4,SX7,UXU,VED6,VEK,VEX7,VMS4,VXU,VX7,WDA6,WKD6,WKT4,WKT6,WME4

2

Ref. No.	Part No.	Description	Reqd. QTY				Serial No.	Parts catalogue code
			(1)	GX120K1 (2)	(3)	(4)		
16	17631-329-003	PACKING, FUEL FILLER CAP (39X58X3)	1	-	-	-	2421922 DS,EN,ET,ETX,HH,HX,HXQ,HX2,LD,LE,LH,LJ,LTJ,LW2,LX,LX2,PH,PM,PM2,PX,QA,QA2,QD,QE,QEH,QH,QH2,QLL,QM,QPU,QSJ,QT,QX,QXC,QXG,QXG2,QXQ,QXS,QXS2,QX2,RD,RH,RX,SCJ,SD,SE,SH,SJ,SKJ,SMJ,SN,STS,SW2,SX,TH,TX,TX2,UH,UX,VA,VED,VED1,VET,VEX,VH,VS,VSX,VSX1,VS1,VX,WJ	
	17631-ZH7-003	.....	-	(1)	-	-	2421922	
			1	(1)	-	-	2421923 EN,ET,ETX,HH,HXQ,LE,LW2,PH,PM,PM2,QE,QEH,QH2,QPU,QSJ,QXC,QXG,QXG2,QXQ,QXS,RH,SKJ,SN,SW2,S1,TH,UH,UX,U1,VA,VH,VS,VS1,V1,W1,DS,HX,HX2,H1,LD,LH,LJ,LTJ,LX,LX2,L1,PX,QA,QA2,QD,QH,QLL,QM,QX,QXS2,QX2,Q1,RD,RX,R1,SCJ,SD,SE,SH,SJ,SMJ,STS,SX,TX,TX2,VED,VED1,VET,VEX,VSX,VSX1,VX,WJ	
			1	-	-	-	4203082 LD4,LEH4,LJT,LX26,QAA2,QA26,QBU2,QJW1,QMH,QTC2,SAD2,SJC,SSK2,WDJ,WJP1	
			1	-	-	-	4203082 HHQ4,HTF2,HT2,HXU,HX26,HX4,LAJ4,LHQ4,LJC,LJD2,LJS,LSJ,LSJ4,LTK1,LXU,LX4,PX2,QHQ4,QH26,QJG2,QMA4,QMA8,QME4,QMX2,QWA4,QXC9,QXU,QX26,QX4,QX7,RD4,RHQ4,RX4,SAJ,SAJ4,SD16,SD4,SG24,SHQ4,SJC1,SJC5,SJD2,SKR,SMA7,SMW2,SM11,SM12,SM14,SSK1,SSK3,SSX2,SSX4,STP,SWX2,SWX4,SXS4,SX4,SX7,TX26,TX4,UXU,VED6,VEK,VEX7,VMS4,VXU,VX4,VX7,WDA6,WD12,WJP,WKD6,WKT2,WKT4,WKT6,WMA3,WME2,WME4	
	17631-329-003	.....	1	-	-	-	2421923 2533057 QT	
			1	-	-	-	LDB1,LDB3,LTA,SDB1,SDB3,VEE1	
			1	-	-	-	2533058 QT	
			-	-	1	1		
17	17672-ZE2-W00	FILTER, FUEL .....	1	-	-	-	1287119 DS,LJ,QSJ,SJ,SMJ,STS,VET,WJ	
			1	-	-	-	2187119 LW2,QA,QT,SN,SW2,VED,VED1,VS,VSX	
			-	(1)	-	-	2187119	
	17672-ZE2-W01	.....	1	-	-	-	LAJ4,LDB3,LJS,LJT,LSJ,LSJ4,LTK1,QAA2,QA26,QLL,QMH,QMX2,QTC2,SAJ,SAJ4,SCJ,SDB3,SJC,SKR,SMW2,SM11,SM12,SM14,SSK1,SSK2,SSK3,SSX2,SSX4,STP,VED6,WDA6,WDJ,WJP,WJP1,WKD6,WKT2,WKT4,WKT6,WME2	
			1	-	-	-	2328483 DS,EN,ET,ETX,LJ,LTA,LTJ,LW2,QA2,QSJ,QT,SJ,SMJ,SN,STS,SW2,VED,VED1,VET,VS,VSX,VSX1,VS1,WJ	
			1	-	-	-	3187097 SJC1,SJC5	
			1	-	-	-	3575682 LJC	
			-	(1)	-	-	2328483	
			-	-	1	-		
	17670-ZH7-A81	FILTER COMP., FUEL .....	1	-	-	-	VEK	
			1	-	-	-	2340188 SKJ	
18	17672-880-000	FILTER, FUEL .....	1	-	-	-	3187098 SJC1,SJC5	
			1	-	-	-	3575683 LJC	
			1	-	-	-	2328482 EN,ET,ETX,LTA,LTJ,QA2,VSX1,VS1	
			1	-	-	-	1287120 2328482 DS,LJ,QSJ,SJ,SMJ,STS,VET,WJ	
			1	-	-	-	2187120 2328482 LW2,QA,QT,SN,SW2,VED,VED1,VS,VSX	
			-	(1)	-	-	2187120 2328482	
	17672-887-791	.....	1	-	-	-	VEE1	
			1	-	-	-	2340187 SKJ	
19	17673-893-000	HOLDER, FUEL FILTER .....	1	-	-	-	VEE1	
			1	-	-	-	3187098 SJC1,SJC5	
			1	-	-	-	3575683 LJC	
			1	-	-	-	2328482 EN,ET,ETX,QA2,VSX1,VS1	
			1	-	-	-	2340187 SKJ	
			1	-	-	-	1287120 2328482 DS,LJ,LTA,LTJ,QSJ,SJ,SMJ,STS,VET,WJ	
			1	-	-	-	2187120 2328482 LW2,QA,QT,SN,SW2,VED,VED1,VS,VSX	
			-	(1)	-	-	2187120 2328482	
20	17682-817-020	RUBBER, TANK CUSHION .....	4	-	-	-	EN,ET,ETX	
21	90506-500-000	WASHER, AIR DUCT .....	2	-	-	-	EN,ET,ETX	
23	90854-ZB2-000	RUBBER, FUEL (9X15X10) .....	1	-	-	-	3095049 VPR4	





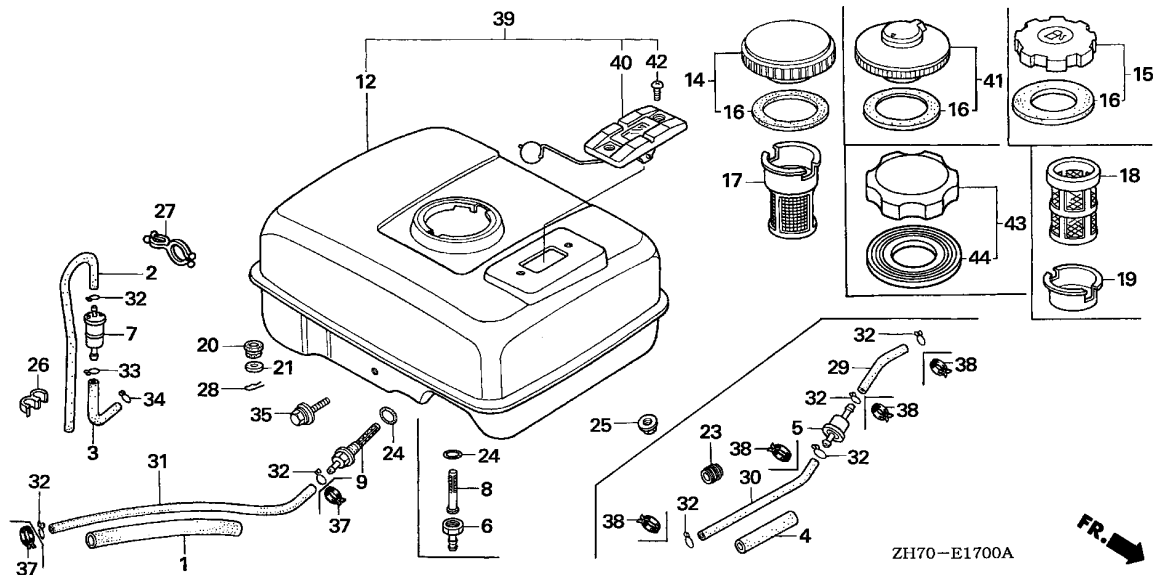

Ref. No.	Part No.	Description	Reqd. QTY				Serial No.	Parts catalogue code
			(1)	(2)	(3)	(4)		
23)	90854-ZB3-000	RUBBER, FUEL (9X15X20) .....	1	-	-	-	3095050 -----	VPR4
24	91353-671-004	O-RING, 14MM(NOK) .....	1	-	-	-	-----	DS, EN, ET, ETX, HH, HHQ4, HTF2, HT2, HX, HXQ, HXU, HX2, HX26, HX4, LAJ4, LD, LDB1, LDB3, LD4, LE, LEH4, LH, LHQ4, LJ, LJC, LJD2, LJS, LJT, LSJ, LSJ4, LTA, LTJ, LTK1, LW2, LX, LXU, LX2, LX26, LX4, PH, PM, PM2, PX, PX2, QA, QAA2, QA2, QA26, QBU2, QD, QE, QEH, QH, QHQ4, QH2, QH26, QJG2, QJW1, QLL, QM, QMA4, QMA8, QME4, QMH, QMX2, QPU, QSJ, QT, QTC2, QWA4, QX, QXC, QXC9, QXG, QXG2, QXQ, QXS, QXS2, QXU, QX2, QX26, QX4, QX7, RD, RD4, RH, RHQ4, RX, RX4, SAD2, SAJ, SAJ4, SCJ, SD, SDB1, SDB3, SD16, SD4, SE, SG24, SH, SHQ4, SJ, SJC, SJC1, SJC5, SJD2, SKJ, SKR, SMA7, SMJ, SMW2, SM11, SM12, SM14, SN, SSK1, SSK2, SSK3, SSSX2, SSSX4, STP, STS, SWX2, SWX4, SW2, SX, SXS4, SX4, SX7, TH, TX, TX2, TX26, TX4, UH, UX, UXU, VA, VED, VED1, VED6, VEE1, VEK, VET, VEX, VEX7, VH, VMS4, VS, VSX, VSX1, VS1, VX, VXU, VX4, VX7, WDA6, WDJ, WD12, WJ, WJP, WJP1, WKD6, WKT2, WKT4, WKT6, WMA3, WME2, WME4
25	94050-06000	NUT, FLANGE, 6MM .....	-	(1)	1	1	-----	AR, DKR, DS, EN, ET, ETX, HH, HHQ4, HTF2, HT2, HX, HXQ, HXU, HX2, HX26, HX4, KRS4, LAJ4, LD, LDB1, LDB3, LD4, LE, LEH4, LH, LHQ4, LJ, LJC, LJD2, LJS, LJT, LSJ, LSJ4, LTA, LTJ, LTK1, LW2, LX, LXU, LX2, LX26, LX4, PH, PM, PM2, PX, PX2, QA, QAA2, QA2, QA26, QBU2, QD, QE, QEH, QH, QHQ4, QH2, QH26, QJG2, QJW1, QLL, QM, QMA4, QMA8, QME4, QMH, QMX2, QPU, QSJ, QT, QTC2, QWA4, QX, QXC, QXC9, QXG, QXG2, QXQ, QXS, QXS2, QXU, QX2, QX26, QX4, QX7, RD, RD4, RH, RHQ4, RX, RX4, SAD2, SAJ, SAJ4, SCJ, SD, SDB1, SDB3, SD16, SD4, SE, SG24, SH, SHQ4, SJ, SJC, SJC1, SJC5, SJD2, SKJ, SKR, SMA7, SMJ, SMW2, SM11, SM12, SM14, SN, SSK1, SSK2, SSK3, SSSX2, SSSX4, STP, STS, SWX2, SWX4, SW2, SX, SXS4, SX4, SX7, TH, TX, TX2, TX26, TX4, UH, UX, UXU, VA, VED, VED1, VED6, VEE1, VEK, VET, VEX, VEX7, VH, VMS4, VS, VSX, VSX1, VS1, VX, VXU, VX4, VX7, WDA6, WDJ, WD12, WJ, WJP, WJP1, WKD6, WKT2, WKT4, WKT6, WMA3, WME2, WME4
			-	(2)	2	2		

2

Ref. No.	Part No.	Description	Reqd. QTY				Serial No.	Parts catalogue code
			(1)	GX120K1 (2)	(3)	(4)		
26	91403-750-800	CLIP, DOUBLE .....	1	-	-	-	4312054 AR,DKR,KR,KRA4,KRT,KRT4,KRT6	
			2	-	-	-	4091237 KRS4	
	17205-PC6-000	CLAMP, TUBE, 7.5X2 .....	2	-	-	-	4312054 KRF4	
			1	-	-	-	4091238 4312054 KRS4	
	91473-PA1-003	CLIP, WATER HOSE .....	1	-	-	-	4312055 AR,DKR,KR,KRA4,KRS4,KRT,KRT4,KRT6	
			2	-	-	-	4312055 KRF4	
27	94251-08000	PIN, LOCK, 8MM .....	1	-	-	-	AR,DKR,KRA4,KRT4	
28	95001-45035-40	TUBE, FUEL, 4.5X35 (95001-45001-60M)	1	-	-	-	EN,ET,ETX,QIH1	
			1	-	-	-	VPR4	
29	95001-45350-60	TUBE, FUEL, 4.5X350 (95001-45001-60M)	1	-	-	-	4091238 KRS4	
			1	-	-	-	VPR4	
30	95001-45110-40	TUBE, FUEL, 4.5X110 (95001-45001-60M)	1	-	-	-	VPR4	
			1	-	-	-	4091238 KRS4	
31	95001-45075-60	TUBE, FUEL, 4.5X75 (95001-45001-60M)	1	-	-	-	KRS4	
			1	-	-	-	KRS4	
31	95001-45140-40	TUBE, FUEL, 4.5X140 (95001-45001-60M)	1	-	-	-	DS,HH,HHQ4,HTF2,HT2,HX,HXQ,HXU,HX2,HX26,HX4,LAJ4,LD,LDB1,LDB3	
			-	(1)	1	1	LD4,LE,LEH4,LH,LHQ4,LJ,LJC,LJD2,LJS,LJT,LSJ,LSJ4,LTA,LTJ,LTJ1	
	95001-45300-40	TUBE, FUEL, 4.5X300 (95001-45001-60M)	1	-	-	-	LW2,LX,LXU,LX2,LX26,LX4,PH,PM,PM2,PX,PX2,QA,QAA2,QA2,QA26,QBU2	
			1	-	-	-	QD,QE,QEH,QH,QHQ4,QH2,QH26,QJG2,QJW1,QLL,QM,QMA4,QMA8,QME4,QMH	
	95001-45350-40	TUBE, FUEL, 4.5X350 (95001-45001-60M)	1	-	-	-	QMX2,QPU,QSJ,QT,QTC2,QWA4,QX,QXC,QXC9,QXG,QXG2,QXQ,QXS,QXS2	
			1	-	-	-	QXU,QX2,QX26,QX4,QX7,RD,RD4,RH,RHQ4,RX,RX4,SAD2,SAJ,SAJ4,SCJ	
	95001-45400-60	TUBE, FUEL, 4.5X400 (95001-45001-60M)	1	-	-	-	SD,SDB1,SDB3,SD16,SD4,SE,SG24,SH,SHQ4,SJ,SJC,SJC1,SJC5,SJD2	
			1	-	-	-	SKJ,SMA7,SMJ,SMW2,SM11,SM12,SM14,SN,SSK1,SSK2,SSK3,SSX2,SSX4	
	95001-45750-40	TUBE, FUEL, 4.5X750 (95001-45001-60M)	1	-	-	-	STP,STS,SWX2,SWX4,SW2,SX,SXS4,SX4,SX7,TH,TX,TX2,TX26,TX4,UH,UX	
			1	-	-	-	UXU,VA,VED,VED1,VED6,VEE1,VEK,VET,VEX,VEX7,VH,VMS4,VS,VSX,VSX1	
32	95002-02080	CLIP, TUBE (B8) .....	1	-	-	-	VS1,VX,VXU,VX4,VX7,WDA6,WDJ,WD12,WJ,WJP,WJP1,WKD6,WKT2,WKT4	
			2	-	-	-	WKT6,WMA3,WME2,WME4	
	95001-45300-40	TUBE, FUEL, 4.5X300 (95001-45001-60M)	1	-	-	-	ET,ETX	
			1	-	-	-	EN	
	95001-45350-40	TUBE, FUEL, 4.5X350 (95001-45001-60M)	1	-	-	-	AR,DKR,KR,KRA4,KRT,KRT4,KRT6	
			1	-	-	-	4091237 KRS4	
	95001-45750-40	TUBE, FUEL, 4.5X750 (95001-45001-60M)	1	-	-	-	SKR	
			1	-	-	-	AR,DKR,KR,KRA4,KRF4,KRT,KRT4,KRT6	
32	95002-02080	CLIP, TUBE (B8) .....	1	-	-	-	DS,EN,ET,ETX,HH,HHQ4,HTF2,HT2,HX,HXQ,HXU,HX2,HX26,HX4,LAJ4,LD	
			2	-	-	-	LDB1,LDB3,LD4,LE,LEH4,LH,LHQ4,LJ,LJC,LJD2,LJS,LJT,LSJ,LSJ4,LTA	
	95001-45300-40	TUBE, FUEL, 4.5X300 (95001-45001-60M)	1	-	-	-	LTJ,LTJ1,LW2,LX,LXU,LX2,LX26,LX4,PH,PM,PM2,PX,PX2,QA,QAA2,QA2	
			1	-	-	-	QA26,QBU2,QD,QE,QEH,QH,QHQ4,QH2,QH26,QJG2,QJW1,QLL,QM,QMA4	
	95001-45350-40	TUBE, FUEL, 4.5X350 (95001-45001-60M)	1	-	-	-	QMA8,QME4,QMH,QMX2,QPU,QSJ,QT,QTC2,QWA4,QX,QXC,QXC9,QXG,QXG2	
			1	-	-	-	QXQ,QXS,QXS2,QXU,QX2,QX26,QX4,QX7,RD,RD4,RH,RHQ4,RX,RX4,SAD2	
	95001-45400-60	TUBE, FUEL, 4.5X400 (95001-45001-60M)	1	-	-	-	SAJ,SAJ4,SCJ,SD,SDB1,SDB3,SD16,SD4,SE,SG24,SH,SHQ4,SJ,SJC,SJC1	
			1	-	-	-	SJC5,SJD2,SKJ,SKR,SMA7,SMJ,SMW2,SM11,SM12,SM14,SN,SSK1,SSK2	
	95001-45750-40	TUBE, FUEL, 4.5X750 (95001-45001-60M)	1	-	-	-	SSK3,SSX2,SSX4,STP,STS,SWX2,SWX4,SW2,SX,SXS4,SX4,SX7,TH,TX,TX2	
			1	-	-	-	TX26,TX4,UH,UX,UXU,VA,VED,VED1,VED6,VEE1,VEK,VET,VEX,VEX7,VH	
	95001-45140-40	TUBE, FUEL, 4.5X140 (95001-45001-60M)	1	-	-	-	VMS4,VS,VSX,VSX1,VS1,VX,VXU,VX4,VX7,WDA6,WDJ,WD12,WJ,WJP,WJP1	
			4	-	-	-	WKD6,WKT2,WKT4,WKT6,WMA3,WME2,WME4	
	95001-45300-40	TUBE, FUEL, 4.5X300 (95001-45001-60M)	1	-	-	-	VPR4	
			-	(2)	2	2	VPR4	
33	95002-02100	CLIP, TUBE (B10) .....	1	-	-	-	AR,DKR,KR,KRA4,KRF4,KRT,KRT4,KRT6	
34	95002-50000	CLIP, TUBE (C9) .....	1	-	-	-	AR,DKR,KR,KRA4,KRF4,KRT,KRT4,KRT6	



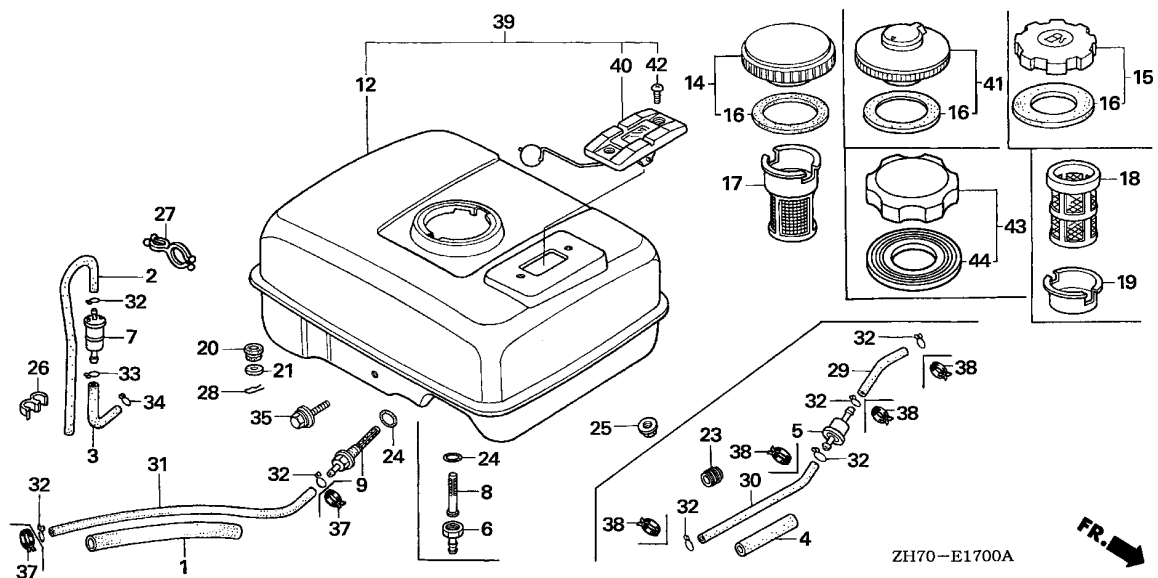

Ref. No.	Part No.	Description	Reqd. QTY				Serial No.	Parts catalogue code
			(1)	(2)	(3)	(4)		
35	95900-06025-00	BOLT, FLANGE, 6X25	1	(1)	1	-	DS,HH,HX,HXU,LD,LE,LH,LJ,LW2,LX,LXU,PH,PM,PM2,PX,QA,QD,QE,QEH,QH,QM,QT,QX,QXC,QXG,QXS,QXU,RD,RH,RX,SD,SE,SH,SJ,SMJ,SN,STS,SW2,SX,TH,UH,UIH,UX,UXU,U1,VA,VED,VED1,VET,VH,VS,VSX,VXU,V1,WJ	
	95701-06025-00		1	-	1	-	EN,ET,ETX,HHQ4,HTF2,HXQ,HX2,HX26,HX4,LAJ4,LDB1,LDB3,LD4,LEH4,LHQ4,LJC,LJD2,LJS,LJT,LSJ,LSJ4,LTA,LTJ,LTJ1,LX2,LX26,LX4,PX2,QAA2,QA2,QA26,QBU2,QHQ4,QH2,QH26,QIH1,QJG2,QJW1,QLL,QME4,QMH,QMX2,QPU,QSJ,QTC2,QXC9,QXG2,QXQ,QXS2,QX2,QX26,QX4,RD4,RHQ4,RX4,SAD2,SAJ,SAJ4,SCJ,SDB1,SDB3,SD16,SD4,SG24,SHQ4,SJC,SJC1,SJC5,SKJ,SMW2,SSK1,SSK2,SSK3,SSX2,SSX4,STP,SWX2,SWX4,SXS4,SX4,TX2,TX26,TX4,VED6,VEE1,VEX,VMS4,VSX1,VS1,VX4,WDJ,WIH1,WJP,WJP1,WKD6,WKT2,WKT4,WME2	
	90004-ZH7-003	BOLT, FLANGE, 6X29	1	(1)	-	-	HT2,H1,L1,QMA4,QMA8,QWA4,QX7,Q1,R1,SJD2,SMA7,SM11,SM12,SM14,SX7,S1,TX,VEK,VEX7,VX,VX7,WDA6,WD12,WKT6,WMA3,WME4,W1	
37	95002-40800-08	CLAMP, TUBE (D8)	2	-	-	-	AR,DKR,KRA4	
38	95002-40850-08	CLAMP, TUBE (D8.5)	2	-	-	4091237	KRS4	
	95002-40800-08	CLAMP, TUBE (D8)	2	-	-	3284617	KRT4	
39	17500-ZE1-813ZA	TANK ASSY., FUEL (GAUGE) *NH31*.....MCKINLEY WHITE	1	-	-	4091238	KRS4	
40	17505-ZH7-A21	GAUGE ASSY., FUEL	1	-	-	-	SKR	
	17505-ZE1-013		1	-	-	-	SKJ,SMJ,VEK	
			1	-	-	-	SKR	
41	17620-ZH7-V91	CAP COMP., FUEL FILLER	1	-	-	2666802	LTA	
	17620-ZH7-V92		1	-	-	2666803	LTA	
42	93600-05010-0A	SCREW, FLAT, 5X10	2	-	-	-	SKJ,SKR,SMJ,VEK	

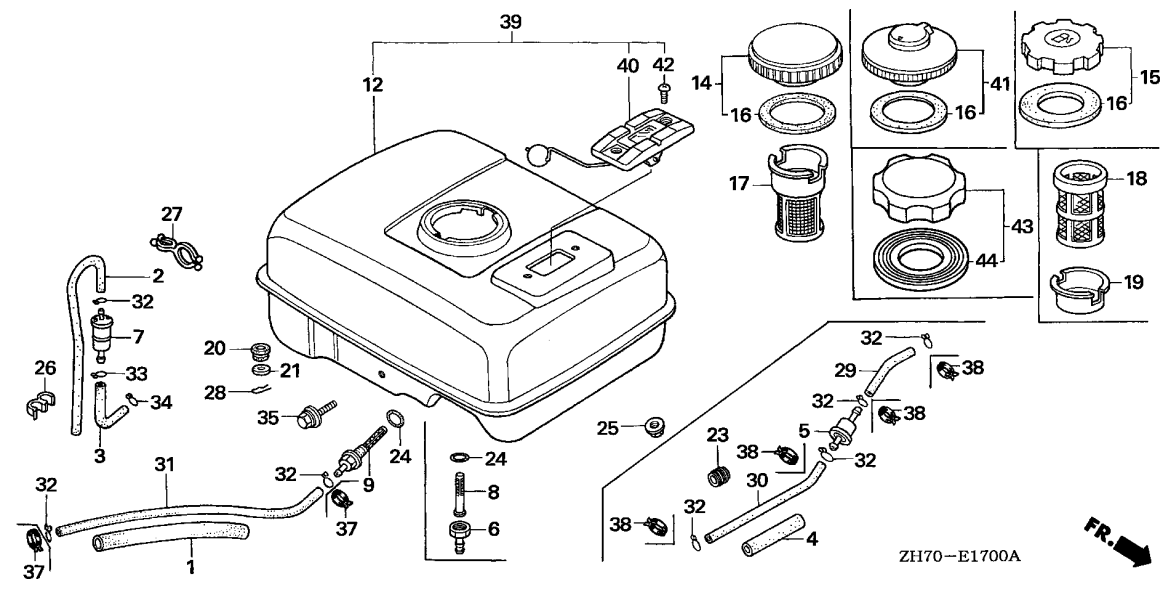

Ref. No.	Part No.	Description	Reqd. QTY				Serial No.	Parts catalogue code
			(1)	(2)	(3)	(4)		
43	17620-Z0T-814	CAP COMP., FUEL FILLER (CHROME PLATED)	1	(1)	-	-	4203083 -----	DS,HHQ4,HTF2,HT2,HX,HXU,HX2,HX26,HX4,H1,LAJ4,LD,LH,LHQ4,LJ,LJC LJD2,LJS,LSJ,LSJ4,LTJ,LTK1,LX,LXU,LX2,LX4,L1,PX,PX2,QA,QA2,QD QH,QHQ4,QH26,QJG2,QLL,QM,QMA4,QMA8,QME4,QMX2,QWA4,QX,QXC9,QXS2 QXU,QX2,QX26,QX4,QX7,Q1,RD,RD4,RHQ4,RX,RX4,R1,SAJ,SAJ4,SCJ,SD SD16,SD4,SE,SG24,SH,SHQ4,SJ,SJC1,SJC5,SJD2,SKR,SMA7,SMJ,SMW2 SM11,SM12,SM14,SSK1,SSK3,SSX2,SSX4,STP,STS,SWX2,SWX4,SX,SXS4 SX4,SX7,TX,TX2,TX26,TX4,UXU,VED,VED1,VED6,VEK,VET,VEX,VEX7 VMS4,VSX,VSX1,VX,VXU,VX4,VX7,WDA6,WD12,WJ,WJP,WKD6,WKT2,WKT4 WKT6,WMA3,WME2,WME4
44	17631-Z0T-812	PACKING, FUEL FILLER CAP (39X62X3)	1	(1)	-	-	4203083 -----	DS,HHQ4,HTF2,HT2,HX,HXU,HX2,HX26,HX4,H1,LAJ4,LD,LH,LHQ4,LJ,LJC LJD2,LJS,LSJ,LSJ4,LTJ,LTK1,LX,LXU,LX2,LX4,L1,PX,PX2,QA,QA2,QD QH,QHQ4,QH26,QJG2,QLL,QM,QMA4,QMA8,QME4,QMX2,QWA4,QX,QXC9,QXS2 QXU,QX2,QX26,QX4,QX7,Q1,RD,RD4,RHQ4,RX,RX4,R1,SAJ,SAJ4,SCJ,SD SD16,SD4,SE,SG24,SH,SHQ4,SJ,SJC1,SJC5,SJD2,SKR,SMA7,SMJ,SMW2 SM11,SM12,SM14,SSK1,SSK3,SSX2,SSX4,STP,STS,SWX2,SWX4,SX,SXS4 SX4,SX7,TX,TX2,TX26,TX4,UXU,VED,VED1,VED6,VEK,VET,VEX,VEX7 VMS4,VSX,VSX1,VX,VXU,VX4,VX7,WDA6,WD12,WJ,WJP,WKD6,WKT2,WKT4 WKT6,WMA3,WME2,WME4



E-17-1

FUEL TANK(2)

K12

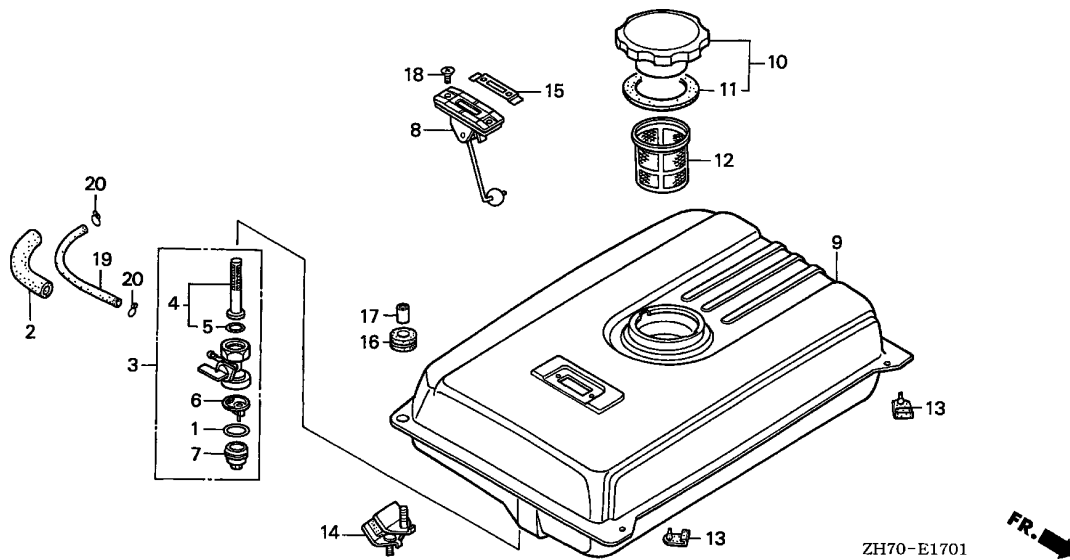

Ref. No.	L.O.N.	(Relative ref. Number) Description	F.R.T.
3	3101A3	COCK, FUEL .....	0.2
4	3101D5	SCREEN, FUEL STRAINER .....	0.2
6	3101A7	FILTER, CUP .....	0.2
8	6171A1	METER UNIT, FUEL .....	0.1
9	3101H7	TANK, FUEL .....	0.2
12	3101A6	FILTER, FUEL .....	0.1
14	4101Q6	RUBBER, BOTTOM .....	0.1
19	3101F2	TUBE, FUEL COCK .....	0.2

Ref. No.	Part No.	Description	Reqd. QTY				Serial No.	Parts catalogue code
			(1)	(2)	(3)	(4)		
1	16173-001-004	PACKING, FUEL STRAINER CUP ..	1	-	-	-	LTR	
2	16854-ZH8-000	RUBBER, SUPPORTER (107MM) ..	1	-	-	-	LTR	
3	16950-ZB4-015	COCK ASSY., FUEL .....	1	-	-	-	LTR	
4	16952-ZB4-005	SCREEN, FUEL STRAINER .....	1	-	-	-	LTR	
5	16958-397-771	O-RING .....	1	-	-	-	LTR	
6	16959-471-831	FILTER, CUP .....	1	-	-	-	LTR	
7	16967-GA6-671	CUP, FUEL STRAINER .....	1	-	-	-	LTR	
8	17505-ZB2-003	METER ASSY., FUEL .....	1	-	-	-	LTR	
9	17510-ZB4-000ZB	TANK COMP., FUEL	1	-	-	-	LTR	
		*R8*.....BRIGHT RED	1	-	-	-	LTR	
10	17620-899-013	CAP COMP., FUEL FILLER .....	1	-	-	-	LTR	
11	17631-899-000	PACKING, FUEL FILLER CAP ....	1	-	-	-	LTR	
12	17670-899-000	FILTER COMP., FUEL .....	1	-	-	-	LTR	
13	50319-ZB2-000	RUBBER, TANK MOUNTING .....	2	-	-	-	LTR	
14	68325-899-000	RUBBER, BOTTOM .....	2	-	-	-	LTR	
15	87565-ZB4-A00	PLATE, FUEL INDICATION .....	1	-	-	-	LTR	
16	90851-898-000	RUBBER, TANK CUSHION .....	2	-	-	-	LTR	
17	91551-898-000	COLLAR, TANK CUSHION .....	2	-	-	-	LTR	
18	93600-05010-0A	SCREW, FLAT, 5X10 .....	2	-	-	-	LTR	
19	95001-45300-40	TUBE, FUEL, 4.5X300	1	-	-	-	LTR	
		(95001-45001-60M)	1	-	-	-	LTR	
20	95002-02080	CLIP, TUBE (B8) .....	2	-	-	-	LTR	

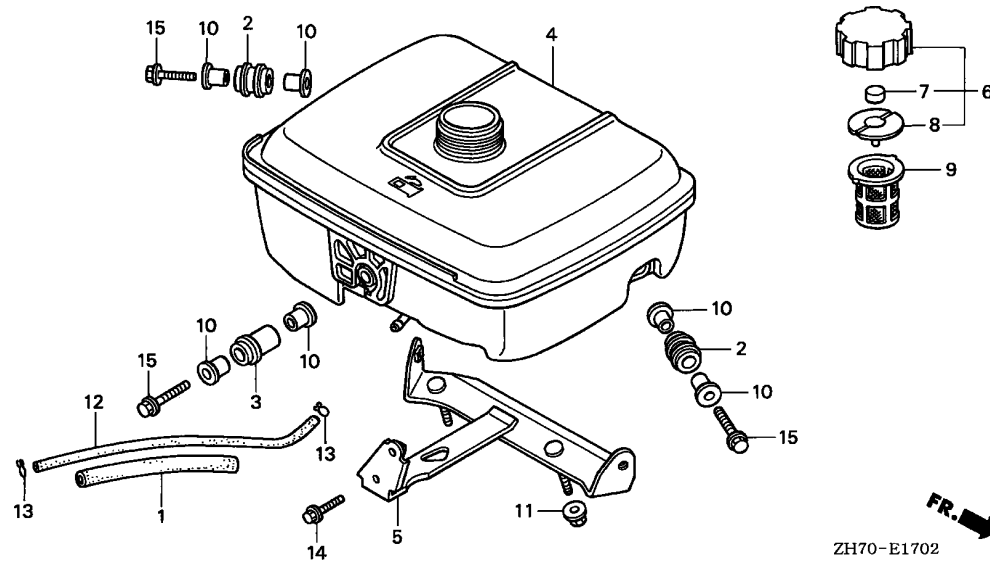

ZH70-E1702

Ref. No.	L.O.N.	(Relative ref. Number) Description	F.R.T.
2	3101G6	RUBBER, TANK SETTING(A) .....	0.1
3	3101G5	RUBBER B, TANK SETTING .....	0.1
	3101G7	RUBBER, TANK SETTING(B) .....	0.1
4	3101H7	TANK, FUEL .....	0.2
5	3101E0	STAY, FUEL TANK .....	0.2
9	3101A6	FILTER, FUEL .....	0.1
12	3101F1	TUBE, FUEL TANK .....	0.2

Ref. No.	Part No.	Description	Reqd. QTY				Serial No.	Parts catalogue code
			(1)	(2)	(3)	(4)		
			GX120K1					
1	16854-ZH8-000	RUBBER, SUPPORTER (107MM) ...	1	-	-	-	-----	WJ1,WM1
2	17506-ZK7-800	RUBBER, TANK SETTING (A) .....	2	-	-	-	-----	WJ1,WM1
3	17507-ZK7-800	RUBBER, TANK SETTING (B) .....	1	-	-	-	-----	WJ1,WM1
4	17510-ZK7-800	TANK COMP., FUEL .....	1	-	-	-	-----	WJ1,WM1
5	17561-ZK7-800	STAY, FUEL TANK .....	1	-	-	-	-----	WJ1,WM1
6	17620-ZE7-000	CAP ASSY., FUEL TANK .....	1	-	-	-	-----	WJ1,WM1
7	17622-888-010	SPONGE, FUEL CAP BREATHER ...	1	-	-	-	-----	WJ1,WM1
8	17624-ZE7-000	PACKING, FUEL CAP .....	1	-	-	-	-----	WJ1,WM1
9	17672-ZK7-800	FILTER, FUEL .....	(1)	-	-	-	-----	WJ1,WM1
10	90509-750-000	COLLAR, FUEL TANK .....	6	-	-	-	-----	WJ1,WM1
11	94050-06000	NUT, FLANGE, 6MM .....	2	-	-	-	-----	WJ1,WM1
12	95001-45140-40	TUBE, FUEL, 4.5X140						
		(95001-45001-60M)	1	-	-	-	-----	WJ1,WM1
13	95002-02080	CLIP, TUBE (B8) .....	2	-	-	-	-----	WJ1,WM1
14	95701-06025-00	BOLT, FLANGE, 6X25 .....	1	-	-	-	-----	WJ1,WM1
15	95701-06032-00	BOLT, FLANGE, 6X32 .....	3	-	-	-	-----	WJ1,WM1

E-17-3

FUEL TANK(4)

K14

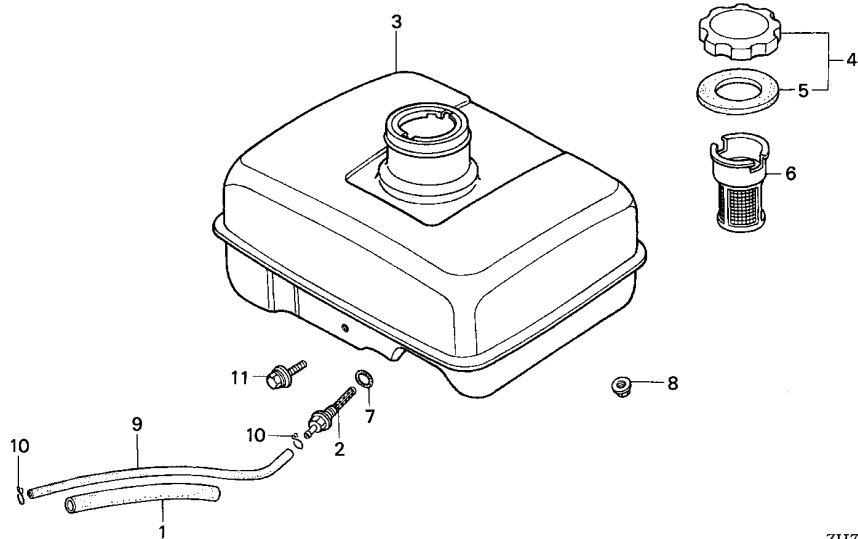

Ref. No.	L.O.N.	(Relative ref. Number) Description	F.R.T.
2	3101H6	STRAINER, JOINT FUEL .....	0.2
3	3101H7	TANK, FUEL .....	0.2
6	3101A6	FILTER, FUEL .....	0.1

2

Ref. No.	Part No.	Description	Reqd. QTY				Serial No.	Parts catalogue code
			(1)	GX120K1 (2)	(3)	(4)		
1	16854-ZH8-000	RUBBER, SUPPORTER (107MM) ...	1	-	-	-	-----	LTS
2	16955-ZE1-000	JOINT, FUEL TANK .....	1	-	-	-	-----	LTS
3	17510-ZK7-U20ZC	TANK COMP., FUEL *R280*.....POWER RED	1	-	-	-	-----	LTS
4	17620-Z0T-814	CAP COMP., FUEL FILLER (CHROME PLATED)	1	-	-	-	-----	LTS
5	17631-Z0T-812	PACKING, FUEL FILLER CAP (39X62X3)	1	-	-	-	-----	LTS
6	17672-ZE2-W01	FILTER, FUEL .....	1	-	-	-	-----	LTS
7	91353-671-004	O-RING, 14MM(NOK) .....	1	-	-	-	-----	LTS
8	94050-06000	NUT, FLANGE, 6MM .....	2	-	-	-	-----	LTS
9	95001-45140-40	TUBE, FUEL, 4.5X140 (95001-45001-60M)	1	-	-	-	-----	LTS
10	95002-02080	CLIP, TUBE (B8) .....	2	-	-	-	-----	LTS
11	90004-ZH7-003	BOLT, FLANGE, 6X29 .....	1	-	-	-	-----	LTS

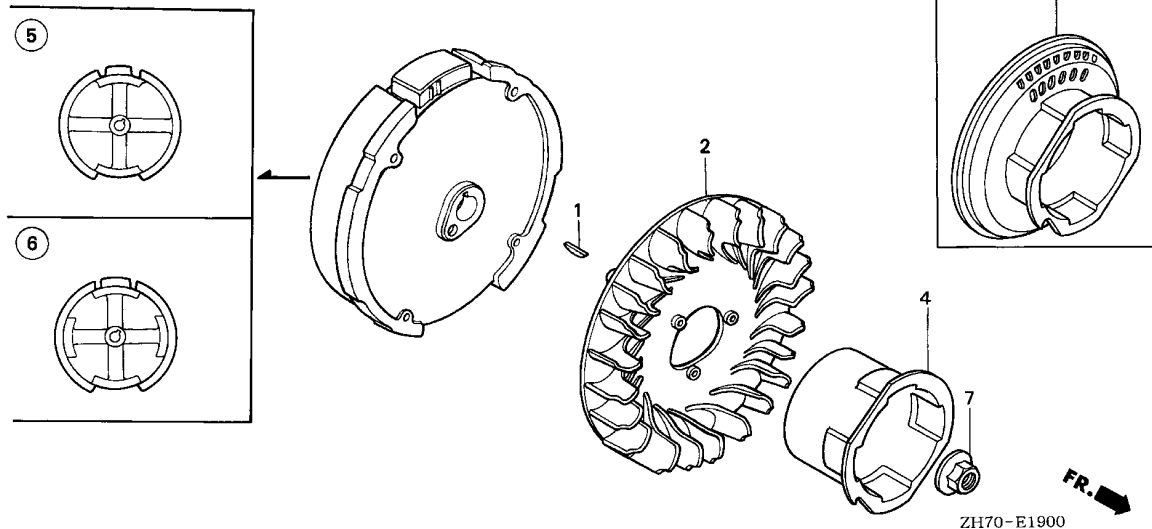

Ref. No.	L.O.N.	(Relative ref. Number) Description	F.R.T.
2	1141G7	FAN, ENGINE COOLING (3)	0.2
4	1121A9	PULLEY, RECOIL STARTER (6)	0.2
5	2161B5	FLYWHEEL (6)	0.3

Ref. No.	Part No.	Description	Reqd. QTY				Serial No.	Parts catalogue code
			(1)	(2)	(3)	(4)		
1	13331-357-000	KEY, SPECIAL WOODRUFF, 25X18	1	1	1	1		
2	19511-ZE0-000	FAN, COOLING .....	1	-	-	-	-----	AR,DKR,DS,EN,ET,ETX,HH,HHQ4,HTF2,HT2,HX,HXQ,HXU,HX2,HX26,HX4 KR,KRA4,KRF4,KRS4,KRT,KRT4,KRT6,LAJ4,LD,LDB1,LDB3,LD4,LE,LEH4 LH,LHQ4,LJ,LJC,LJD2,LJS,LJT,LSJ,LSJ4,LTA,LTJ,LTK1,LTR,LTS,LW2 LX,LXU,LX2,LX26,LX4,PH,PM,PM2,PX,PX2,QA,QAA2,QA2,QA26,QBU2 QB26,QD,QE,QEH,QH,QHQ4,QH2,QH26,QJG2,QJW1,QLL,QM,QMA4,QMA8 QME4,QMH,QMX2,QPU,QSJ,QT,QTC2,QWA4,QX,QXC,QXC9,QXG,QXG2,QXQ QXS,QXS2,QXU,QX2,QX26,QX4,QX7,RD,RD4,RH,RHC,RHQ4,RX,RX4,SAD2 SAJ,SAJ4,SCJ,SD,SDB1,SDB3,SD16,SD4,SE,SG24,SH,SHQ4,SJ,SJC,SJC1 SJD2,SKJ,SKR,SMA7,SMJ,SMW2,SM11,SM12,SM14,SN,SSK1,SSK2,SSK3 SSX2,SSX4,STP,STS,SWX2,SWX4,SW2,SX,SXS4,SX4,SX7,TH,TX,TX2,TX26 TX4,UH,UX,UXU,VA,VAX4,VED,VED1,VED6,VEE1,VEK,VET,VEX,VEX7,VH VMS4,VMT,VPR4,VS,VSX,VSX1,VS1,VX,VXU,VX4,VX7,WDA6,WDJ,WD12,WJ WJP,WJP1,WJ1,WKD6,WKT2,WKT4,WKT6,WMA3,WME2,WME4,WM1
	19511-ZE1-000	..... (COMPRESSOR COOLING)	-	1	1	1	-----	SJC,SJC1,SJC5
3	28450-ZH7-811	PULLEY COMP., STARTER .....	1	-	-	-	-----	LE,LJT,LTJ,LTS,QA,QAA2,QA2,QA26,QBU2,QE,QMA8,QWA4,SAD2,SE,SG24 SMA7,VEK
			-	(1)	-	-		





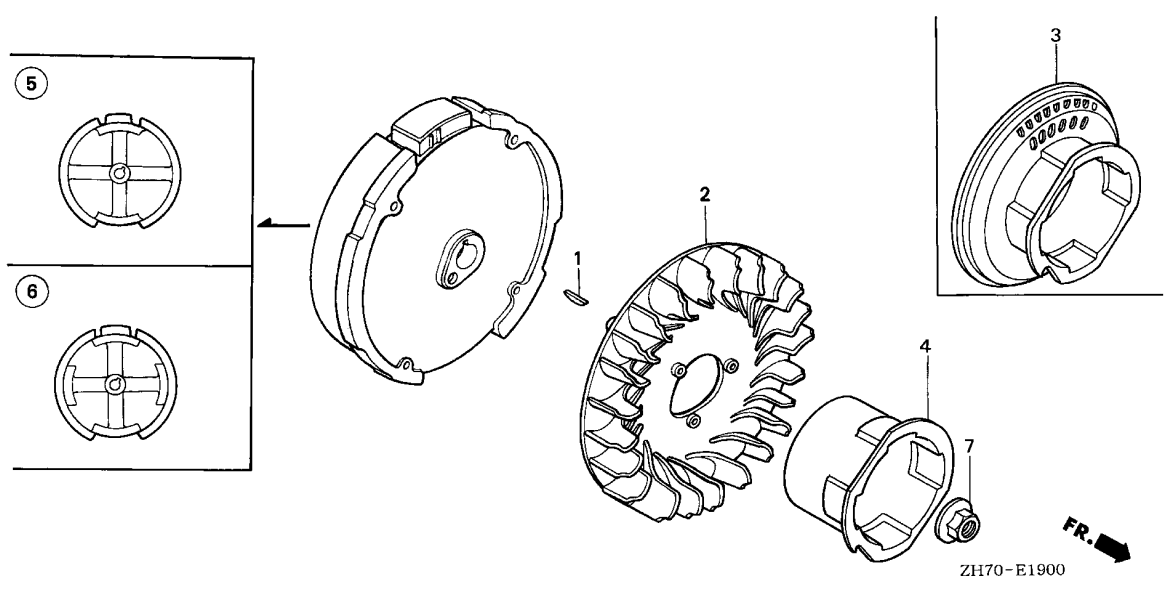

Ref. No.	Part No.	Description	Reqd. QTY				Serial No.	Parts catalogue code
			(1)	(2)	(3)	(4)		
4	28451-ZH8-003	PULLEY, STARTER .....	1	(1)	1	-	-----	EN,ET,ETX,HH,HXQ,LDB1,LDB3,LD4,LEH4,LTA,LW2,L1,PM2,QEH,QH2 QJW1,QMH,QPU,QSJ,QXC,QXG,QXQ,QXS,RH,SDB1,SDB3,SJC,SN,SSK1,SSK2 SW2,S1,UIH,U1,VA,VAX4,VH,VS,VS1,V1,WDJ,WJ1,W1
			1	(1)	-	-	-----	3917140 AR,DKR,DS,HHQ4,HTF2,HX,HXU,HX2,HX26,HX4,H1,KR,KRA4,KRT,KRT4 KRT6,LAJ4,LD,LH,LHQ4,LJ,LJC,LJD2,LJS,LSJ,LSJ4,LTK1,LTR,LX,LXU LX2,LX26,LX4,PH,PM,PX,PX2,QB26,QD,QH,QHQ4,QH26,QJG2,QLL,QM QMA4,QME4,QMX2,QTC2,QX,QXC9,QXG2,QXS2,QXU,QX2,QX26,QX4,Q1,RD RD4,RHC,RHQ4,RX,RX4,R1,SAJ,SAJ4,SCJ,SD,SD16,SD4,SH,SHQ4,SJ SJC1,SJC5,SKJ,SKR,SMJ,SMW2,SM11,SSK3,SSX2,SSX4,STP,STS,SWX2 SWX4,SX,SXS4,SX4,TH,TX,TX2,TX26,TX4,UH,UX,UXU,VED,VED1,VED6 VEE1,VET,VEX,VMS4,VMT,VPR4,VSX,VSX1,VX,VXU,VX4,WDA6,WD12,WJ WJP,WJP1,WKD6,WKT2,WKT4,WMA3,WME2,WME4,WM1
			1	-	-	-	-----	3463997 QT
	28451-ZE0-003	.....	1	-	-	-	-----	3463998 QT
	28451-ZH7-003	.....	1	(1)	-	-	-----	3917141 AR,DKR,DS,HHQ4,HTF2,HX,HXU,HX2,HX26,HX4,H1,KR,KRA4,KRT,KRT4 KRT6,LAJ4,LD,LH,LHQ4,LJ,LJC,LJD2,LJS,LSJ,LSJ4,LTK1,LTR,LX,LXU LX2,LX26,LX4,PH,PM,PX,PX2,QB26,QD,QH,QHQ4,QH26,QJG2,QLL,QM QMA4,QME4,QMX2,QTC2,QX,QXC9,QXG2,QXS2,QXU,QX2,QX26,QX4,Q1,RD RD4,RHC,RHQ4,RX,RX4,R1,SAJ,SAJ4,SCJ,SD,SD16,SD4,SH,SHQ4,SJ SJC1,SJC5,SKJ,SKR,SMJ,SMW2,SM11,SSK3,SSX2,SSX4,STP,STS,SWX2 SWX4,SX,SXS4,SX4,TH,TX,TX2,TX26,TX4,UH,UX,UXU,VED,VED1,VED6 VEE1,VET,VEX,VMS4,VMT,VPR4,VSX,VSX1,VX,VXU,VX4,WDA6,WD12,WJ WJP,WJP1,WKD6,WKT2,WKT4,WMA3,WME2,WME4,WM1
5	31100-ZE0-000	FLYWHEEL COMP. ....	1	-	1	-	-----	HT2,KRF4,KRS4,QIH1,QX7,SJD2,SM12,SM14,SX7,VEX7,VX7,WIH1,WKT6 U1,W1

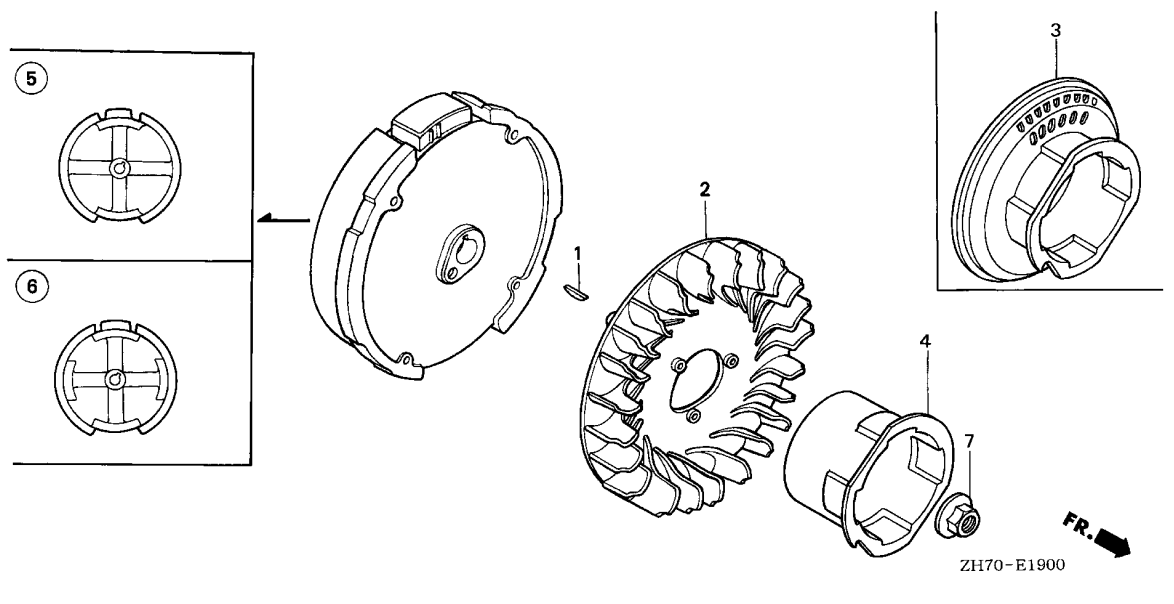

Ref. No.	Part No.	Description	Reqd. QTY				Serial No.	Parts catalogue code
			(1)	(2)	(3)	(4)		
(5)	31100-ZE0-010	FLYWHEEL COMP. ....	1	-	-	-	-----	AR,DKR,DS,EN,ET,ETX,HH,HHQ4,HTF2,HT2,HX,HXQ,HXU,HX2,HX26,HX4 KR,KRA4,KRF4,KRS4,KRT,KRT4,KRT6,LD,LDB1,LDB3,LD4,LE,LEH4,LH LHQ4,LJ,LJC,LJT,LSJ,LSJ4,LTA,LTJ,LTK1,LTR,LTS,LX,LXU,LX2,LX26 LX4,PH,PM,PM2,PX,PX2,QA,QAA2,QA2,QA26,QBU2,QD,QE,QEH,QH,QHQ4 QH2,QH26,QJW1,QLL,QM,QMA4,QMA8,QME4,QMH,QMX2,QPU,QSJ,QT,QTC2 QWA4,QX,QXC,QXC9,QXG,QXG2,QXQ,QXU,QX2,QX26,QX4,QX7,RD,RD4,RH RHQ4,RX,RX4,SAD2,SAJ,SAJ4,SCJ,SD,SDB1,SDB3,SD16,SD4,SE,SG24,SH SHQ4,SJ,SJC,SJC1,SJC5,SKR,SMA7,SMJ,SMW2,SM11,SM12,SM14,SN,SSK1 SSK2,SSK3,SSX2,SSX4,STP,STS,SWX2,SWX4,SW2,SX,SXS4,SX4,SX7,TH TX,TX2,TX26,TX4,UH,UX,UXU,VA,VAX4,VED,VED1,VED6,VEE1,VEK,VET VEX,VEX7,VH,VMS4,VMT,VPR4,VS,VSX,VSX1,VS1,VX,VXU,VX4,VX7,WDA6 WDJ,WD12,WJ,WJP,WJP1,WJ1,WKD6,WKT2,WKT4,WKT6,WMA3,WME2,WME4 WM1
			1	-	-	-	-----	3093870 LJD2
			-	(1)	1	1		
6	31100-ZE0-810	FLYWHEEL COMP. (LAMP) .....	-	(1)	-	-	-----	H1,U1,V1,W1
	31100-ZE0-811	.....	1	(1)	-	-	-----	LAJ4,LJS,LW2,L1,QB26,QJG2,QXS,QXS2,Q1,RHC,R1,SJD2,SKJ,S1,W1
			1	-	-	-	3093871	LJD2
7	90201-878-003	NUT, SPECIAL, 14MM .....	1	1	1	1		

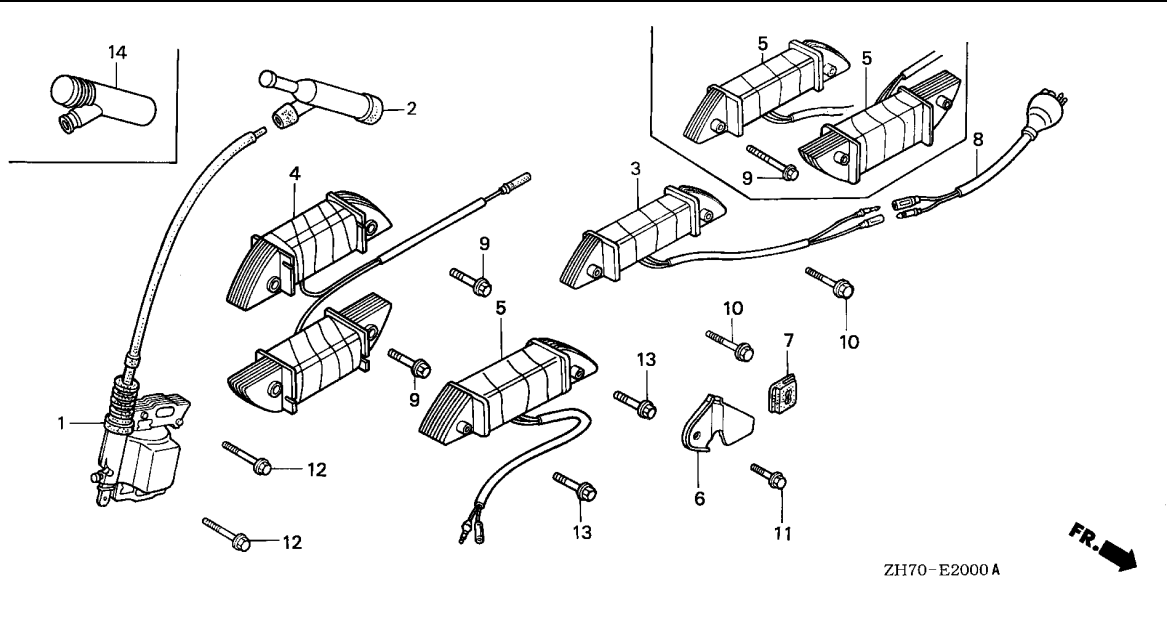

Ref. No.	L.O.N.	(Relative ref. Number) Description	F.R.T.
1	6141A5	COIL, IGNITION (14)	0.2
2	6141B8	TERMINAL, HIGH TENSION	0.1
4	6141A6	COIL, LAMP (3,5)	0.3
8	6141C5	CABLE, DOUBLE CONNECTOR	0.1

ZH70-E2000 A



Ref. No.	Part No.	Description	Reqd. QTY				Serial No.	Parts catalogue code
			(1)	(2)	(3)	(4)		
1	30500-ZE1-023	COIL ASSY., IGNITION	1	-	-	-	2400125	DS,EN,ET,ETX,HH,HX,LD,LE,LH,LJ,LTA,LTJ,LW2,LX,PH,PM,PM2,PX,QA,QD,QE,QEH,QH,QLL,QM,QPU,QSJ,QT,QX,QXC,QXG,QXS,RD,RH,RHC,RX,SCJ,SD,SE,SH,SJ,SKJ,SMJ,SN,STS,SW2,SX,TH,TX,UH,UX,VA,VED,VED1,VET,VEX,VH,VS,VSX,VSX1,VS1,VX,WJ
			1	-	-	-	2402519	HXQ,HX2,LX2,QA2,QH2,QXG2,QXQ,QXS2,QX2,TX2
			-	(1)	-	-		U1
			-	(1)	-	-	2401279	H1,L1,Q1,R1,S1,V1,W1
	30500-ZE1-033		1	-	1	-		HTF2,HT2,HX26,KRS4,LDB1,LDB3,LD4,LEH4,LJS,LJT,LTR,LX26,PX2,QAA2,QA26,QBU2,QH26,QJW1,QMH,QMX2,QTC2,QXC9,QX26,SAD2,SAJ,SDB1,SDB3,SD16,SG24,SJC,SJC1,SMW2,SSK1,SSK2,SSK3,SSX4,STP,SWX2,SWX4,TX26,UIH,VAX4,VED6,WDA6,WDJ,WJP,WJP1,WJ1,WKD6,WKT2,WME2
			1	-	-	-	2400126	DS,EN,ET,ETX,HH,HX,LD,LE,LH,LJ,LTA,LTJ,LW2,LX,PH,PM,PM2,PX,QA,QD,QE,QEH,QH,QLL,QM,QPU,QSJ,QT,QX,QXC,QXG,QXS,RD,RH,RHC,RX,SCJ,SD,SE,SH,SJ,SKJ,SMJ,SN,STS,SW2,SX,TH,TX,UH,UX,VA,VED,VED1,VET,VEX,VH,VS,VSX,VSX1,VS1,VX,WJ
			1	-	-	-	2402520	HXQ,HX2,LX2,QA2,QH2,QXG2,QXQ,QXS2,QX2,TX2
			1	-	-	-	4075104	AR,DKR,HHQ4,HXU,HX4,KR,KRA4,KRF4,KRT,KRT4,KRT6,LAJ4,LHQ4,LJC,LJD2,LSJ,LSJ4,LTK1,LXU,LX4,QB26,QHQ4,QJG2,QMA4,QMA8,QME4,QWA4,QXU,QX4,RD4,RHQ4,RX4,SAJ4,SD4,SHQ4,SJC5,SJD2,SKR,SMAT7,SM11,SM14,SSX2,SXS4,SX4,TX4,UXU,VEE1,VEK,VMS4,VMT,VPR4,VXU,VX4,WD12,WKT4,WKT6,WMA3,WME4,WM1
			-	(1)	-	-	2401280	L1,S1,V1,W1
			-	(1)	-	-	2401280	4075104 H1,Q1,R1
			-	-	-	1		



Ref. No.	Part No.	Description	Reqd. QTY				Serial No.	Parts catalogue code
			(1)	GX120K1 (2)	(3)	(4)		
(1)	30500-ZE1-043	COIL ASSY., IGNITION .....	1	(1)	-	-	4075105 ----- AR,DKR,HHQ4,HXU,HX4,H1,KR,KRA4,KRF4,KRT,KRT4,KRT6,LAJ4,LHQ4,LJC,LJD2,LSJ,LSJ4,LTK1,LXU,LX4,QB26,QHQ4,QJG2,QMA4,QMA8,QME4,QWA4,QXU,QX4,Q1,RD4,RHQ4,RX4,R1,SAJ4,SD4,SHQ4,SJC5,SJD2,SKR,SMA7,SM11,SM14,SSX2,SXS4,SX4,TX4,UXU,VEE1,VEK,VMS4,VMT,VPR4,VXU,VX4,WD12,WKT4,WKT6,WMA3,WME4,WM1	
2	30600-ZE1-013	TERMINAL ASSY., HIGH TENSION (NICHIWA Y-EZ)	1	-	1	-	----- LTS,QIH1,QX7,SM12,SX7,VEX7,VX7,WIH1	
			1	-	-	-	----- EN,ET,ETX,KRT6,LDB1,LJC,LTA,LTK1,LW2,PM,PM2,QM,QSJ,QT,SN,STP,STS,SW2,VEK,VS1	
			1	-	-	2816332 ----- VSX,VSX1		
			1	-	-	2689722 ----- LD4,RD4,SD4,WMA3		
			1	-	-	2923462 ----- WJP1		
			1	-	-	3235089 ----- AR,DKR		
			1	-	-	3491424 ----- DS,KR,KRT,LD,LDB3,LJ,LJT,LSJ,LTJ,LTR,QD,RD,SAJ,SCJ,SD,SDB1,SDB3,SJ,SJC,SJC1,SJC5,SKJ,SKR,SMJ,SSK1,SSK3,VED,VEE1,VET,VS,WDJ,WJ,WJP,WJ1,WM1		
	30700-ZE1-013	CAP ASSY., NOISE SUPPRESSOR (NICHIWA Y-EZ RTFM256)	-	(1)	1	-		
			1	-	-	-	----- HH,HHQ4,HTF2,HT2,HX,HXQ,HXU,HX2,HX26,HX4,KRA4,KRF4,KRT4,LAJ4,LE,LEH4,LH,LHQ4,LJD2,LJS,LSJ4,LTS,LX,LXU,LX2,LX26,LX4,PH,FX,PX2,QA,QA2,QA2,QA26,QBU2,QB26,QE,QEH,QH,QHQ4,QH2,QH26,QJG2,QJW1,QLL,QMA4,QMA8,QME4,QMH,QMX2,QPU,QTC2,QWA4,QX,QXC,QXC9,QXG,QXG2,QXQ,QXS,QXS2,QXU,QX2,QX26,QX4,QX7,RH,RHC,RHQ4,RX,RX4,SAD2,SAJ4,SD16,SE,SG24,SH,SHQ4,SJD2,SMA7,SMW2,SM11,SM12,SM14,SSK2,SSX2,SSX4,SWX2,SWX4,SX,SXS4,SX4,SX7,TH,TX,TX2,TX26,TX4,UH,UX,UXU,VA,VAX4,VED1,VED6,VEX,VEX7,VH,VMS4,VMT,VX,VXU,VX4,VX7,WDA6,WD12,WKD6,WKT2,WKT4,WKT6,WME2,WME4	
			1	-	-	2689723 ----- LD4,RD4,SD4,WMA3		
			1	-	-	2923463 ----- WJP1		
			1	-	-	3235090 ----- AR,DKR		
			1	-	-	3491425 ----- DS,KR,KRT,LD,LDB3,LJ,LJT,LSJ,LTJ,LTR,QD,RD,SAJ,SCJ,SD,SDB1,SDB3,SJ,SJC,SJC1,SJC5,SKJ,SKR,SMJ,SSK1,SSK3,VED,VEE1,VET,VS,WDJ,WJ,WJP,WJ1,WM1		
			1	-	-	2816331 ----- VSX,VSX1		
			-	(1)	-	1		
	30700-ZF5-013	CAP ASSY., NOISE SUPPRESSOR	1	-	-	-	----- VPR4	
3	31510-ZE1-003	COIL ASSY., LAMP (12V/15W) ..	-	(1)	-	-		
	31510-ZE1-821	COIL ASSY., LAMP (6V/15W) ...	-	(1)	-	-		
	31610-ZH7-003	COIL ASSY., LAMP (12V/15W) ..	-	(1)	-	-		
4	31510-ZE1-711	COIL ASSY., LAMP (12V/50W) ..	1	-	-	-	----- LW2,QJG2,QXS,QXS2,RHC	
			-	(1)	-	-		
	31510-ZK7-U50	.....	1	-	-	-	----- QB26	
5	31510-ZE1-811	COIL ASSY., LAMP (12V/25W) ..	1	-	-	-	----- LAJ4	
			2	-	-	-	----- LJS,SKJ	
			-	(1)	-	-		
	31510-ZE1-831	COIL ASSY., LAMP (6V/25W) ...	-	(1)	-	-		
6	31511-ZE1-000	CLAMPER, CORD .....	1	-	-	-	----- LAJ4,LJS,LW2,QB26,QJG2,QXS,QXS2,RHC,SKJ	
			-	(1)	-	-		
7	31512-ZE1-000	GROMMET, CORD .....	1	-	-	-	----- LAJ4,LJS,LW2,QB26,QJG2,QXS,QXS2,RHC,SKJ	
			-	(1)	-	-		
8	32105-ZE1-000	CABLE, DOUBLE CONNECTOR .....	-	(1)	-	-		
9	90015-883-000	BOLT, FLANGE, 6X28 .....	4	-	-	-	----- LJS,LW2,QB26,QJG2,QXS,QXS2,RHC,SKJ	
			-	(4)	-	-		
10	90018-ZE1-000	BOLT, FLANGE, 6X23(CT200) ...	-	(2)	-	-		
11	90019-883-000	BOLT, FLANGE, 5X10 .....	1	-	-	-	----- LAJ4,LJS,LW2,QB26,QJG2,QXS,QXS2,RHC,SKJ	
			-	(1)	-	-		



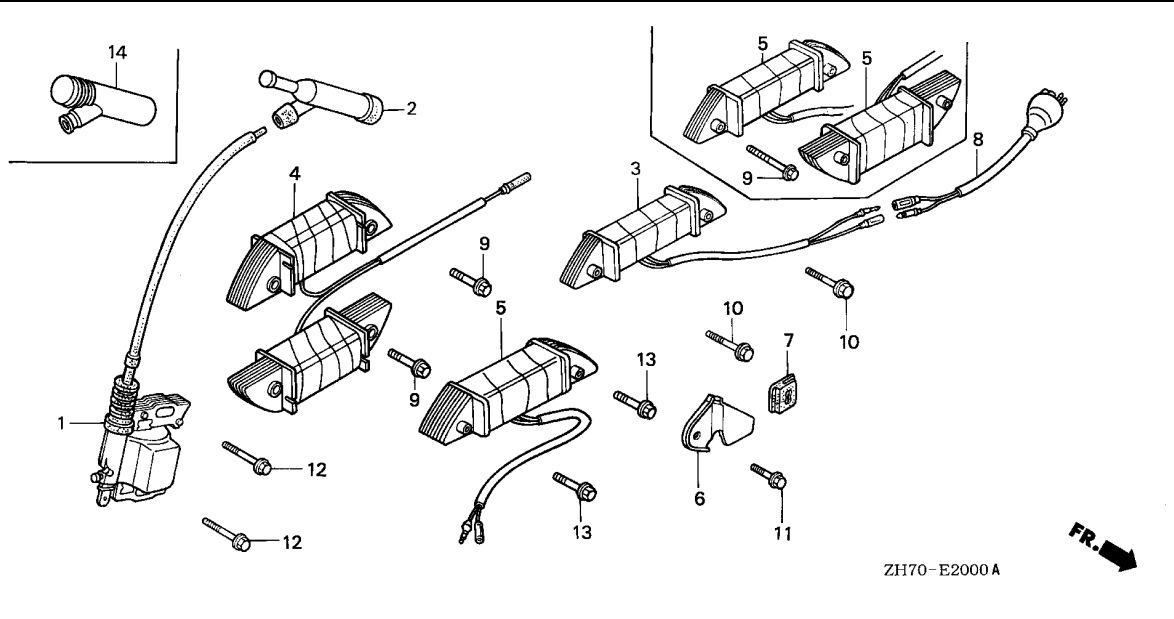

ZH70-E2000 A



Ref. No.	Part No.	Description	Reqd. QTY				Serial No.	Parts catalogue code
			(1)	(2)	(3)	(4)		
			GX120K1					
12	90121-952-000	BOLT, FLANGE, 6X25 .....	2	2	2	2		
13	90015-883-000	BOLT, FLANGE, 6X28 .....	2	-	-	-	----- LAJ4	
14	30700-ZE8-003	CAP ASSY., NOISE SUPPRESSOR -	1	(2)	-	-	----- KRS4	

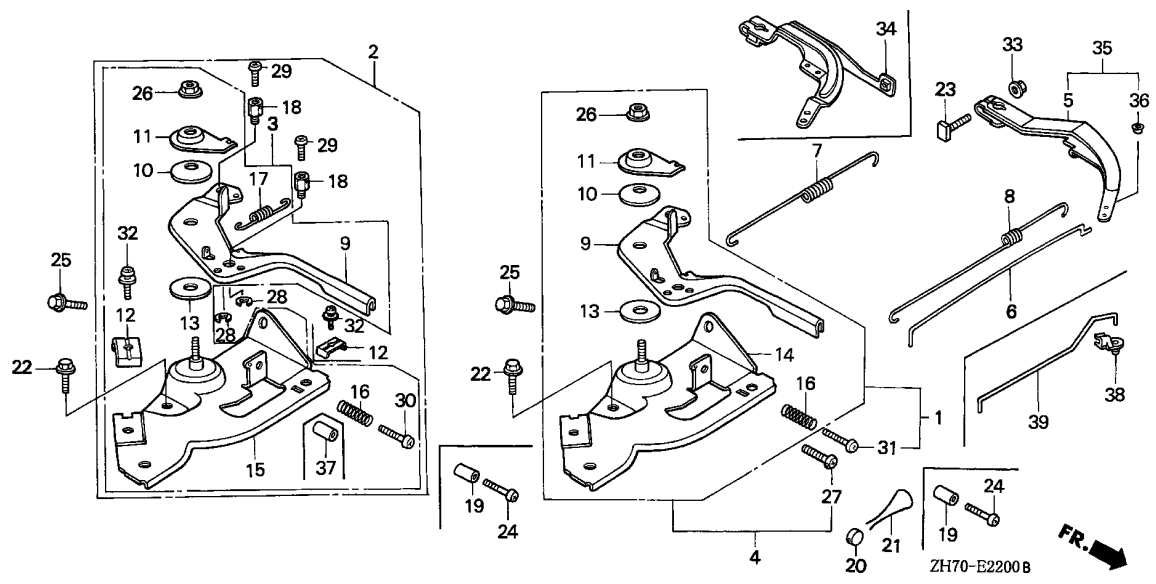

Ref. No.	L.O.N.	(Relative ref. Number) Description	F.R.T.
1		(2) CONTROL, THROTTLE/GOVERNOR ... (34)	0.3
5	1161A5	ARM, GOVERNOR .....	0.3
6	1161B1	ROD, GOVERNOR .....	0.3
7	1161C5	SPRING, GOVERNOR .....	0.2
8	1161C2	SPRING, THROTTLE RETURN .....	0.3
9	1161A8	LEVER, CONTROL .....	0.3
14		(15) BASE, CONTROL .....	0.3

Ref. No.	Part No.	Description	Reqd. QTY				Serial No.	Parts catalogue code
			(1)	(2)	(3)	(4)		
1	16500-ZH7-000	CONTROL ASSY. ....	1	-	-	-	PH,PX, PX2, TH, TX, TX2, TX26, TX4, UH, UX, UXU, VA, VH, VX, VX4, VX7, WDA6, WD12, WJ1, WMA3, WME4, WM1	
	16500-ZH7-860	.....	-	(1)	-	1	3422682 VXU	
2	16500-ZH7-850	CONTROL ASSY. (CYCLONE) ....	1	-	-	-	QXC, QXC9	
	16570-ZE0-900	CONTROL ASSY. (TAC) .....	1	-	-	-	2119399 STS	
	16570-ZE0-901	.....	1	-	-	-	3303356 STP	
	16570-ZE0-902	.....	1	-	-	-	2119400 3303356 STS	
	16500-ZH7-810	CONTROL ASSY. (REMOTE) .....	1	-	-	-	3303357 3461859 STP, STS	
			1	-	-	-	3461860 STP, STS	
			1	-	-	-	DS, LAJ4, LJ, LJC, LJS, LJT, LSJ, LSJ4, LTJ, LTK1, LTR, QBU2, QJG2, QMA8, QME4, QMX2, QSJ, QTC2, QWA4, QXG, QXG2, SAD2, SAJ, SAJ4, SCJ, SG24, SJ, SJC, SJC1, SJC5, SKJ, SKR, SMA7, SMJ, SMW2, VET, WDJ, WJ, WJP, WJP1, WKD6, WKT2, WKT4, WKT6, WME2	
			1	-	-	-	2423947 SSK1	
			1	-	-	-	3093870 VEE1	
	16570-ZE0-S00	.....	1	(1)	-	-	2476407 QLL	
	16570-ZE0-S10	CONTROL ASSY. ....	1	-	-	-	AR, DKR, KR, KRA4, KRF4, KRS4, KRT, KRT4, KRT6, LTA	
	16570-ZK7-U20	.....	1	-	-	-	3418989 LJD2	
			1	-	-	-	SJD2	
			1	-	-	-	3418990 LJD2	
	16500-ZK7-U50	CONTROL ASSY. (REMOTE) .....	1	-	-	-	QB26, SM11, SM12, SM14	
	16500-ZK7-V60	CONTROL ASSY. (REMOTE INT) ..	1	-	-	-	3093871 VEE1	
	16570-ZH7-W40	CONTROL ASSY. (TB360) .....	1	-	-	-	2476408 QLL	
	16500-ZK7-S40	CONTROL ASSY. ....	1	-	-	-	LTS	



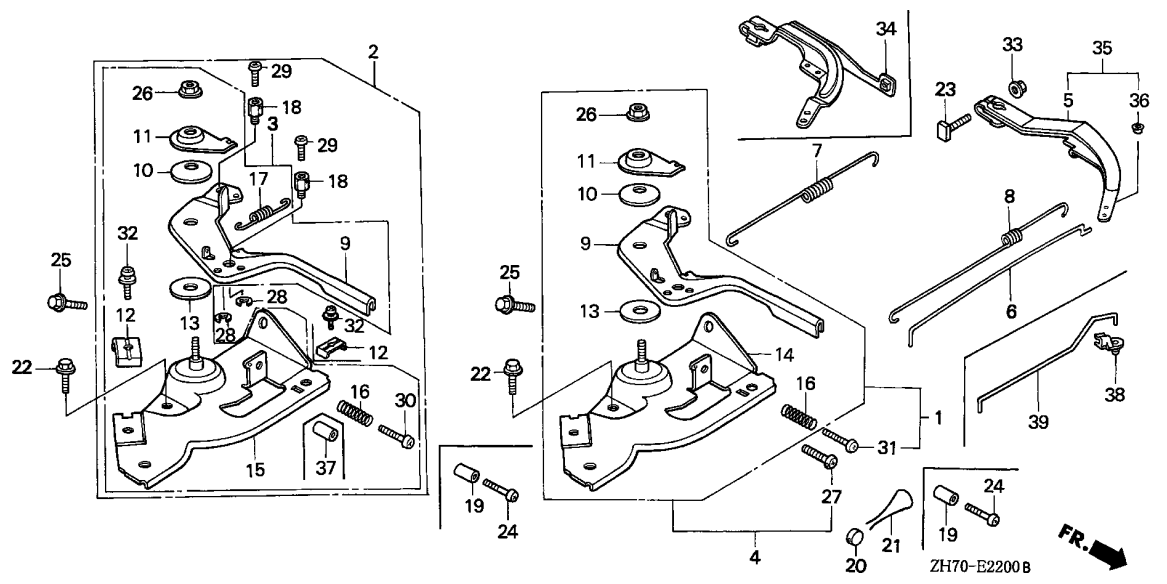

Ref. No.	Part No.	Description	Reqd. QTY				Serial No.	Parts catalogue code
			(1)	(2)	(3)	(4)		
3	16500-ZH7-820	CONTROL ASSY. (REMOTE)	1	-	-	-	HH,HHQ4,HTF2,HT2,HX,HXQ,HXU,HX2,HX26,HX4,LD,LDB1,LDB3,LD4,LE,LEH4,LH,LHQ4,LW2,LX,LXU,LX2,LX26,LX4,PM,PM2,QA,QA2,QA26,QD,QE,QEH,QH,QHQ4,QH2,QH26,QJW1,QM,QMA4,QMH,QPU,QT,QX,QXQ,QXS,QXS2,QXU,QX2,QX26,QX4,QX7,RD,RD4,RH,RHC,RHQ4,RX,RX4,SD,SDB1,SDB3,SD16,SD4,SE,SH,SHQ4,SN,SWX2,SWX4,SW2,SX,SXS4, SX4, SX7	
	16500-ZH7-U40	CONTROL ASSY. (SAKAI)	-	(1)	1	-	SSK2 3303356 SSK3,SSX4	
	16500-ZH7-U41		1	-	-	2423948	3303356 SSK1	
	16500-ZH7-U42		1	-	-	3303357	3461859 SSK1,SSK3,SSX4	
	16500-ZH7-830	CONTROL ASSY. (LOCK TYPE)	1	-	-	3461860	SSX2 SSK1,SSK3,SSX4	
5	16551-ZE0-010	ARM, GOVERNOR	1	-	-	-	DS,HH,HHQ4,HTF2,HT2,HX,HXQ,HXU,HX2,HX26,HX4,LAJ4,LD,LDB1,LDB3,LD4,LE,LEH4,LH,LHQ4,LJ,LJC,LJD2,LJS,LJT,LSJ,LSJ4,LTA,LTJ,LTK1,LTR,LTS,LW2,LX,LXU,LX2,LX26,LX4,PH,PM,PM2,PX, PX2,QA,QA2,QA26,QBU2,QB26,QD,QE,QEH,QH,QHQ4,QH2,QH26,QJG2,QJW1,QLL,QM,QMA4,QMA8,QME4,QMH,QMX2,QPU,QSJ,QT,QTC2,QWA4,QX,QXC,QXC9,QXG,QXG2,QXQ,QXS,QXS2,QXU,QX2,QX26,QX4,QX7,RD,RD4,RH,RHC,RHQ4,RX,RX4,SAD2,SAJ,SAJ4,SCJ,SD,SDB1,SDB3,SD16,SD4,SE,SG24,SH,SHQ4,SJ,SJC,SJC1,SJD2,SKJ,SKR,SMA7,SMW2,SM11,SM12,SM14,SN,SSK1,SSK2,SSK3,SSX2,SSX4,STP,STS,SWX2,SWX4,SW2,SX,SXS4, SX4, SX7, TH, TX, TX2, TX26, TX4, UH, UX, UXU, VA, VEE1, VET, VH, VX, VX4, VX7, WDA6, WDJ, WD12, WJ, WJP, WJP1, WJ1, WKD6, WKT2, WKT4, WKT6, WMA3, WME2, WME4, WM1	
	16551-ZK7-S30		1	-	-	-	3422682 VXU KRS4	

2

Ref. No.	Part No.	Description	Reqd. QTY				Serial No.	Parts catalogue code
			(1)	GX120K1 (2)	(3)	(4)		
6	16555-ZE0-000	ROD, GOVERNOR .....	1	-	-	-	AR,DKR,DS,HH,HHQ4,HTF2,HT2,HX,HXQ,HXU,HX2,HX26,HX4,KR,KRA4 KRF4,KRT,KRT4,KRT6,LAJ4,LD,LDB1,LDB3,LD4,LE,LEH4,LH,LHQ4,LJ LJC,LJD2,LJS,LJT,LSJ,LSJ4,LTA,LTJ,LTJ1,LTR,LTS,LW2,LX,LXU,LX2 LX26,LX4,PH,PM,PM2,PX,PX2,QA,QAA2,QA2,QA26,QBU2,QB26,QD,QE,QEH QH,QHQ4,QH2,QH26,QJG2,QJW1,QLL,QM,QMA4,QMA8,QME4,QMH,QMX2,QPU QSJ,QT,QTC2,QWA4,QX,QXC,QXC9,QXG,QXG2,QXQ,QXS,QXS2,QXU,QX2 QX26,QX4,QX7,RD,RD4,RH,RHC,RHQ4,RX,RX4,SAD2,SAJ,SAJ4,SCJ,SD SDB1,SDB3,SD16,SD4,SE,SG24,SH,SHQ4,SJ,SJC,SJC1,SJC5,SJD2,SKJ SKR,SMA7,SMJ,SMW2,SM11,SM12,SM14,SN,SSK1,SSK2,SSK3,SSX2,SSX4 STP,STS,SWX2,SWX4,SW2,SX,SXS4,SX4,SX7,TH,TX,TX2,TX26,TX4,UH,UX UXU,VA,VEE1,VET,VH,VX,VX4,VX7,WDA6,WDJ,WD12,WJ,WJP,WJP1,WJ1 WKD6,WKT2,WKT4,WKT6,WMA3,WME2,WME4,WM1	
			1	-	-	-	3422682 VXU	
			-	1	1	1		
7	16561-ZE0-020	SPRING, GOVERNOR .....	1	-	-	-	AR,DKR,DS,HH,HHQ4,HTF2,HT2,HX,HXQ,HXU,HX2,HX26,HX4,KR,KRA4 KRF4,KRS4,KRT,KRT4,KRT6,LAJ4,LD,LDB1,LDB3,LD4,LE,LEH4,LH,LHQ4 LJ,LJC,LJD2,LJS,LJT,LSJ,LSJ4,LTA,LTJ,LTJ1,LTR,LTS,LW2,LX,LXU LX2,LX26,LX4,PH,PM,PM2,PX,PX2,QA,QAA2,QA2,QA26,QBU2,QB26,QD,QE QEH,QH,QHQ4,QH2,QH26,QJG2,QJW1,QLL,QM,QMA4,QMA8,QME4,QMH,QMX2 QPU,QSJ,QT,QTC2,QWA4,QX,QXC,QXC9,QXG,QXG2,QXQ,QXS,QXS2,QXU,QX2 QX26,QX4,QX7,RD,RD4,RH,RHC,RHQ4,RX,RX4,SAD2,SAJ,SAJ4,SCJ,SD SDB1,SDB3,SD16,SD4,SE,SG24,SH,SHQ4,SJ,SJC,SJC1,SJC5,SJD2,SKJ SKR,SMA7,SMJ,SMW2,SM11,SM12,SM14,SN,SSK1,SSK2,SSK3,SSX2,SSX4 STP,STS,SWX2,SWX4,SW2,SX,SXS4,SX4,SX7,TH,TX,TX2,TX26,TX4,UH,UX UXU,VA,VEE1,VET,VH,VX,VX4,VX7,WDA6,WDJ,WD12,WJ,WJP,WJP1,WJ1 WKD6,WKT2,WKT4,WKT6,WMA3,WME2,WME4,WM1	
			1	-	-	-	3422682 VXU	
			-	1	1	1		
8	16562-ZE0-020	SPRING, THROTTLE RETURN .....	1	-	-	-	AR,DKR,DS,HH,HHQ4,HTF2,HT2,HX,HXQ,HXU,HX2,HX26,HX4,KR,KRA4 KRF4,KRS4,KRT,KRT4,KRT6,LAJ4,LD,LDB1,LDB3,LD4,LE,LEH4,LH,LHQ4 LJ,LJC,LJD2,LJS,LJT,LSJ,LSJ4,LTA,LTJ,LTJ1,LTR,LTS,LW2,LX,LXU LX2,LX26,LX4,PH,PM,PM2,PX,PX2,QA,QAA2,QA2,QA26,QBU2,QB26,QD,QE QEH,QH,QHQ4,QH2,QH26,QJG2,QJW1,QLL,QM,QMA4,QMA8,QME4,QMH,QMX2 QPU,QSJ,QT,QTC2,QWA4,QX,QXC,QXC9,QXG,QXG2,QXQ,QXS,QXS2,QXU,QX2 QX26,QX4,QX7,RD,RD4,RH,RHC,RHQ4,RX,RX4,SAD2,SAJ,SAJ4,SCJ,SD SDB1,SDB3,SD16,SD4,SE,SG24,SH,SHQ4,SJ,SJC,SJC1,SJC5,SJD2,SKJ SKR,SMA7,SMJ,SMW2,SM11,SM12,SM14,SN,SSK1,SSK2,SSK3,SSX2,SSX4 STP,STS,SWX2,SWX4,SW2,SX,SXS4,SX4,SX7,TH,TX,TX2,TX26,TX4,UH,UX UXU,VA,VEE1,VET,VH,VX,VX4,VX7,WDA6,WDJ,WD12,WJ,WJP,WJP1,WJ1 WKD6,WKT2,WKT4,WKT6,WMA3,WME2,WME4,WM1	
			1	-	-	-	3422682 VXU	
			-	1	1	1		
9	16571-ZH7-000	LEVER, CONTROL .....	1	-	-	-	DS,HH,HHQ4,HTF2,HT2,HX,HXQ,HXU,HX2,HX26,HX4,LAJ4,LD,LDB1,LDB3 LD4,LE,LEH4,LH,LHQ4,LJ,LJC,LJS,LJT,LSJ,LSJ4,LTJ,LTJ1,LTR,LTS LW2,LX,LXU,LX2,LX26,LX4,PH,PM,PM2,PX,PX2,QA,QAA2,QA2,QA26,QBU2 QB26,QD,QE,QEH,QH,QHQ4,QH2,QH26,QJG2,QJW1,QLL,QM,QMA4,QMA8 QME4,QMH,QMX2,QPU,QSJ,QT,QTC2,QWA4,QX,QXC,QXC9,QXG,QXG2,QXQ QXS,QXS2,QXU,QX2,QX26,QX4,QX7,RD,RD4,RH,RHC,RHQ4,RX,RX4,SAD2 SAJ,SAJ4,SCJ,SD,SDB1,SDB3,SD16,SD4,SE,SG24,SH,SHQ4,SJ,SJC,SJC1 SJC5,SKJ,SKR,SMA7,SMJ,SMW2,SM11,SM12,SM14,SN,SWX2,SWX4,SW2,SX SXS4,SX4,SX7,TH,TX,TX2,TX26,TX4,UH,UX,UXU,VA,VEE1,VET,VH,VX VX4,VX7,WDA6,WDJ,WD12,WJ,WJP,WJP1,WJ1,WKD6,WKT2,WKT4,WKT6,WMA3 WME2,WME4,WM1	
			1	-	-	-	2119399 STS	
			1	-	-	-	2423947 SSK1	
			1	-	-	-	3422682 VXU	
			-	(1)	1	1		
16571-ZH7-860	.....		-	(1)	-	-		





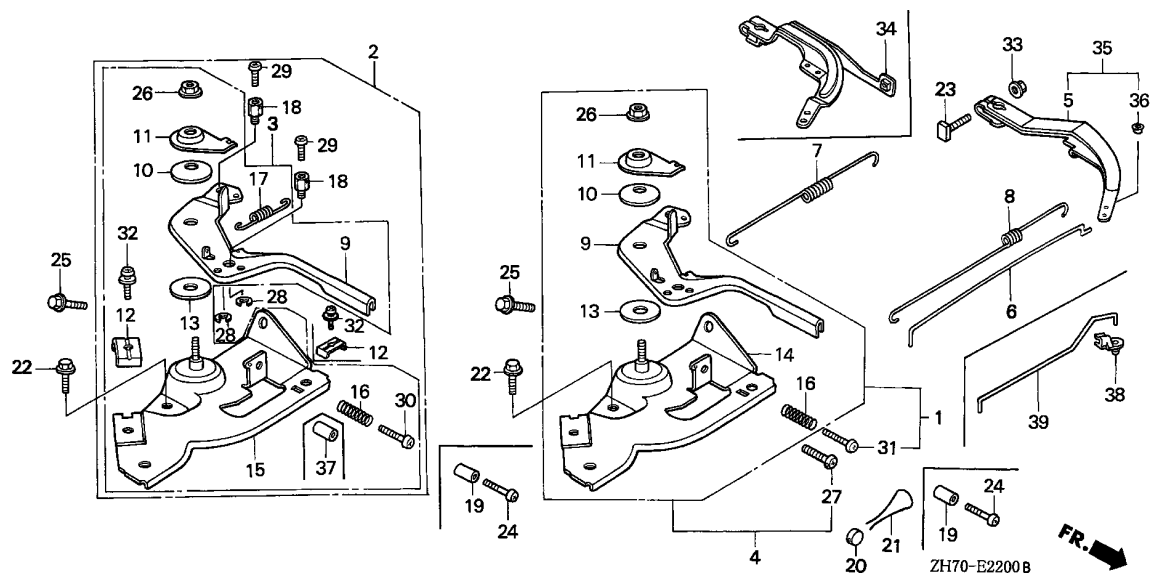

ZH70-E2200B



Ref. No.	Part No.	Description	Reqd. QTY				Serial No.	Parts catalogue code
			(1)	(2)	(3)	(4)		
(9)	16571-ZH8-000	LEVER, CONTROL .....	1	-	-	-	SSK2	
			1	-	-	-	3303356 SSK3,SSX4,STP	
			1	-	-	2119400	3303356 STS	
			1	-	-	2423948	3303356 SSK1	
	16571-ZE0-S10	.....	1	-	-	-	AR,DKR,KR,KRA4,KRF4,KRS4,KRT,KRT4,KRT6,LJD2,LTA,SJD2	
	16571-ZH7-U40	.....	1	-	-	3303357	3461859 SSK1,SSK3,SSX4,STP,STS	
	16571-ZH7-U41	.....	1	-	-	-	SSX2	
10	16574-ZE1-000	SPRING, LEVER .....	1	-	-	3461860	SSK1,SSK3,SSX4,STP,STS	
			1	-	-	-	AR,DKR,DS,HH,HHQ4,HTF2,HT2,HX,HXQ,HXU,HX2,HX26,HX4,KR,KRA4	
							KRF4,KRS4,KRT,KRT4,KRT6,LAJ4,LD,LDB1,LDB3,LD4,LE,LEH4,LH,LHQ4	
							LJ,LJC,LJD2,LJS,LJT,LSJ,LSJ4,LTA,LTJ,LTK1,LTR,LTS,LW2,LX,LXU	
							LX2,LX26,LX4,PH,PM,PM2,PX,PX2,QA,QAA2,QA2,QA26,QBU2,QB26,QD,QE	
							QEH,QH,QHQ4,QH2,QH26,QJG2,QJW1,QLL,QM,QMA4,QMA8,QME4,QMH,QMX2	
							QPU,QSJ,QT,QTC2,QWA4,QX,QXC,QXC9,QXG,QXG2,QXQ,QXS,QXS2,QXU,QX2	
							QX26,QX4,QX7,RD,RD4,RH,RHC,RHQ4,RX,RX4,SAD2,SAJ,SAJ4,SCJ,SD	
							SDB1,SDB3,SD16,SD4,SE,SG24,SH,SHQ4,SJ,SJC,SJC1,SJC5,SJD2,SKJ	
							SKR,SMA7,SMJ,SMW2,SM11,SM12,SM14,SN,SSK1,SSK2,SSK3,SSX2,SSX4	
							STP,STS,SWX2,SWX4,SW2,SX,SXS4,SX4,SX7,TH,TX,TX2,TX26,TX4,UH,UX	
							UXU,VA,VEE1,VET,VH,VX,VX4,VX7,WDA6,WDJ,WD12,WJ,WJP,WJP1,WJ1	
							WKD6,WKT2,WKT4,WKT6,WMA3,WME2,WME4,WM1	
			1	-	-	-	3422682 VXU	
			-	(1)	1	1		

Ref. No.	Part No.	Description	Reqd. QTY				Serial No.	Parts catalogue code
			(1)	GX120K1 (2)	(3)	(4)		
11	16575-ZH8-000	WASHER, CONTROL LEVER .....	1	-	-	-	AR,DKR,DS,HH,HHQ4,HTF2,HT2,HX,HXQ,HXU,HX2,HX26,HX4,KR,KRA4 KRF4,KRS4,KRT,KRT4,KRT6,LAJ4,LD,LDB1,LDB3,LD4,LE,LEH4,LH,LHQ4 LJ,LJC,LJD2,LJS,LJT,LSJ,LSJ4,LTA,LTJ,LTK1,LTR,LTS,LW2,LX,LXU LX2,LX26,LX4,PH,PM,PM2,PX,PX2,QA,QAA2,QA2,QA26,QBU2,QB26,QD,QE QEH,QH,QHQ4,QH2,QH26,QJG2,QJW1,QLL,QM,QMA4,QMA8,QME4,QMH,QMX2 QPU,QSJ,QT,QTC2,QWA4,QX,QXC,QXC9,QXG,QXG2,QXQ,QXS,QXS2,QXU,QX2 QX26,QX4,QX7,RD,RD4,RH,RHC,RHQ4,RX,RX4,SAD2,SAJ,SAJ4,SCJ,SD SDB1,SDB3,SD16,SD4,SE,SG24,SH,SHQ4,SJ,SJC,SJC1,SJC5,SJD2,SKJ SKR,SMA7,SMJ,SMW2,SM11,SM12,SM14,SN,SSK1,SSK2,SSK3,SSX2,SSX4 STP,STS,SWX2,SWX4,SW2,SX,SXS4,SX4,SX7,TH,TX,TX2,TX26,TX4,UH,UX UXU,VA,VEE1,VET,VH,VX,VX4,VX7,WDA6,WDJ,WD12,WJ,WJP,WJP1,WJ1 WKD6,WKT2,WKT4,WKT6,WMA3,WME2,WME4,WM1 3422682 VXU	
			1	(1)	1			
12	16576-891-000	HOLDER, CABLE .....	1	-	-	-	AR,DKR,DS,HH,HHQ4,HTF2,HT2,HX,HXQ,HXU,HX2,HX26,HX4,KR,KRA4 KRF4,KRS4,KRT,KRT4,KRT6,LAJ4,LD,LDB1,LDB3,LD4,LE,LEH4,LH,LHQ4 LJ,LJC,LJD2,LJS,LJT,LSJ,LSJ4,LTA,LTJ,LTK1,LTR,LTS,LW2,LX,LXU LX2,LX26,LX4,PM,PM2,QA,QAA2,QA2,QA26,QBU2,QD,QE,QEH,QH,QHQ4 QH2,QH26,QJG2,QJW1,QLL,QM,QMA4,QMA8,QME4,QMH,QMX2,QPU,QSJ,QT QTC2,QWA4,QX,QXC,QXC9,QXG,QXG2,QXQ,QXS,QXS2,QXU,QX2,QX26,QX4 QX7,RD,RD4,RH,RHC,RHQ4,RX,RX4,SAD2,SAJ,SAJ4,SCJ,SD,SDB1,SDB3 SD16,SD4,SE,SG24,SH,SHQ4,SJ,SJC,SJC1,SJC5,SJD2,SKJ,SKR,SMA7 SMJ,SMW2,SN,SSK1,SSK2,SSK3,SSX2,SSX4,STP,STS,SWX2,SWX4,SW2,SX SXS4,SX4,SX7,VEE1,VET,WDJ,WJ,WJP,WJP1,WKD6,WKT2,WKT4,WKT6,WME2 QB26,SM11,SM12,SM14	
			2	(1)	1			
13	16578-ZE1-000	SPACER, CONTROL LEVER .....	1	-	-	-	AR,DKR,DS,HH,HHQ4,HTF2,HT2,HX,HXQ,HXU,HX2,HX26,HX4,KR,KRA4 KRF4,KRS4,KRT,KRT4,KRT6,LAJ4,LD,LDB1,LDB3,LD4,LE,LEH4,LH,LHQ4 LJ,LJC,LJD2,LJS,LJT,LSJ,LSJ4,LTA,LTJ,LTK1,LTR,LTS,LW2,LX,LXU LX2,LX26,LX4,PH,PM,PM2,PX,PX2,QA,QAA2,QA2,QA26,QBU2,QB26,QD,QE QEH,QH,QHQ4,QH2,QH26,QJG2,QJW1,QLL,QM,QMA4,QMA8,QME4,QMH,QMX2 QPU,QSJ,QT,QTC2,QWA4,QX,QXC,QXC9,QXG,QXG2,QXQ,QXS,QXS2,QXU,QX2 QX26,QX4,QX7,RD,RD4,RH,RHC,RHQ4,RX,RX4,SAD2,SAJ,SAJ4,SCJ,SD SDB1,SDB3,SD16,SD4,SE,SG24,SH,SHQ4,SJ,SJC,SJC1,SJC5,SJD2,SKJ SKR,SMA7,SMJ,SMW2,SM11,SM12,SM14,SN,SSK1,SSK2,SSK3,SSX2,SSX4 STP,STS,SWX2,SWX4,SW2,SX,SXS4,SX4,SX7,TH,TX,TX2,TX26,TX4,UH,UX UXU,VA,VEE1,VET,VH,VX,VX4,VX7,WDA6,WDJ,WD12,WJ,WJP,WJP1,WJ1 WKD6,WKT2,WKT4,WKT6,WMA3,WME2,WME4,WM1 3422682 VXU	
			1	(1)	1			
14	16580-ZH7-000	BASE COMP., CONTROL .....	1	-	-	-	PH,PX,PX2,TH,TX,TX2,TX26,TX4,UH,UX,UXU,VA,VH,VX,VX4,VX7,WDA6 WD12,WJ1,WMA3,WME4,WM1 3422682 VXU	
			1	(1)	1			
15	16580-ZH7-850	BASE COMP., CONTROL (CYCLONE)	1	-	-	-	QXC,QXC9	
	16580-ZH7-R00	BASE COMP., CONTROL .....	1	-	-	-	3303356 STP,STS	
			1	-	-	-	3303357 STP,STS	



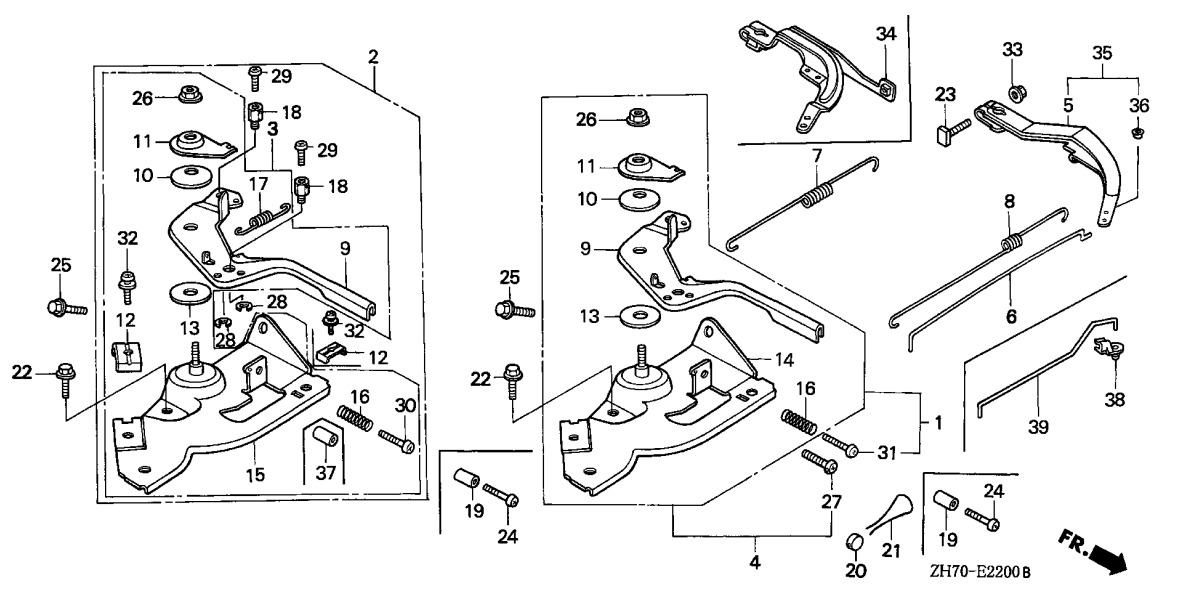

ZH70-E2200B

Ref. No.	Part No.	Description	Reqd. QTY				Serial No.	Parts catalogue code	
			(1)	(2)	(3)	(4)			
15)	16580-ZH7-810	BASE COMP., CONTROL .....	1	-	-	-	AR,DKR,DS,HH,HHQ4,HTF2,HT2,HX,HXQ,HXU,HX2,HX26,HX4,KR,KRA4,KRF4,KRS4,KRT,KRT4,KRT6,LAJ4,LD,LDB1,LDB3,LD4,LE,LEH4,LH,LHQ4,LJ,LJC,LJD2,LJS,LJT,LSJ,LSJ4,LTA,LTJ,LTK1,LTR,LTS,LW2,LX,LXU,LX2,LX26,LX4,PM,PM2,QA,QAA2,QA2,QA26,QBU2,QB26,QD,QE,QEH,QH,QHQ4,QH2,QH26,QJG2,QJW1,QLL,QM,QMA4,QMA8,QME4,QMH,QMX2,QPU,QSJ,QT,QTC2,QWA4,QX,QXC,QXC9,QXG,QXG2,QXQ,QXS,QXS2,QXU,QX2,QX26,QX4,QX7,RD,RD4,RH,RHC,RHQ4,RX,RX4,SAD2,SAJ,SAJ4,SCJ,SD,SDB1,SDB3,SD16,SD4,SE,SG24,SH,SHQ4,SJ,SJC,SJC1,SJC5,SJD2,SKJ,SKR,SMA7,SMJ,SMW2,SM11,SM12,SM14,SN,SSK2,SWX2,SWX4,SW2,SX,SXS4,SX4,SX7,VEE1,VET,WDJ,WJ,WJP,WJP1,WKD6,WKT2,WKT4,WKT6,WME2	3303356	SSK1,SSK3,SSX4
	16580-ZH7-U40	.....	1	(1)	1	-	SSX2	SSK1,SSK3,SSX4	
16	16584-883-300	SPRING, CONTROL ADJUSTING ...	1	-	-	-	AR,DKR,DS,HH,HHQ4,HTF2,HT2,HX,HXQ,HXU,HX2,HX26,HX4,KR,KRA4,KRF4,KRS4,KRT,KRT4,KRT6,LAJ4,LD,LDB1,LDB3,LD4,LE,LEH4,LH,LHQ4,LJ,LJC,LJD2,LJS,LJT,LSJ,LSJ4,LTA,LTJ,LTK1,LTR,LTS,LW2,LX,LXU,LX2,LX26,LX4,PH,PM,PM2,PX,PX2,QA,QAA2,QA2,QA26,QBU2,QB26,QD,QE,QEH,QH,QHQ4,QH2,QH26,QJG2,QJW1,QLL,QM,QMA4,QMA8,QME4,QMH,QMX2,QPU,QSJ,QT,QTC2,QWA4,QX,QXC,QXC9,QXG,QXG2,QXQ,QXS,QXS2,QXU,QX2,QX26,QX4,QX7,RD,RD4,RH,RHC,RHQ4,RX,RX4,SAD2,SAJ,SAJ4,SCJ,SD,SDB1,SDB3,SD16,SD4,SE,SG24,SH,SHQ4,SJ,SJC,SJC1,SJC5,SJD2,SKJ,SKR,SMA7,SMJ,SMW2,SM11,SM12,SM14,SN,SSK1,SSK2,SSK3,SSX2,SSX4,STP,STS,SWX2,SWX4,SW2,SX,SXS4,SX4,SX7,TH,TX,TX2,TX26,UX,UXU,VA,VEE1,VET,VH,VX,VX4,VX7,WDA6,WDJ,WD12,WJ,WJP,WJP1,WJ1,WKD6,WKT2,WKT4,WKT6,WMA3,WME2,WME4,WM1	3422682	VXU

2

Ref. No.	Part No.	Description	Reqd. QTY			Serial No.	Parts catalogue code
			(1)	GX120K1 (2)	(3)		
17	16592-ZE1-810	SPRING, CABLE RETURN .....	1	-	-	-	AR,DKR,DS,HH,HHQ4,HTF2,HT2,HX,HXQ,HXU,HX2,HX26,HX4,KR,KRA4,KRF4,KRS4,KRT,KRT4,KRT6,LAJ4,LD,LDB1,LDB3,LD4,LE,LEH4,LH,LHQ4,LJ,LJC,LJD2,LJS,LJT,LSJ,LSJ4,LTA,LTJ,LTK1,LTR,LTS,LW2,LX,LXU,LX2,LX26,LX4,PM,PM2,QA,QAA2,QA2,QA26,QBU2,QB26,QD,QE,QEH,QH,QHQ4,QH2,QH26,QJG2,QJW1,QLL,QM,QMA4,QMA8,QME4,QMH,QMX2,QPU,QS,J,QT,QTC2,QWA4,QX,QXC,QXC9,QXG,QXG2,QXQ,QXS,QXS2,QXU,QX2,QX26,QX4,QX7,RD,RD4,RH,RHC,RHQ4,RX,RX4,SAD2,SAJ,SAJ4,SCJ,SD,SDB1,SDB3,SD16,SD4,SE,SG24,SH,SHQ4,SJ,SJC,SJC1,SJC5,SJD2,SKJ,SKR,SMA7,SMJ,SMW2,SM11,SM12,SM14,SN,SSK1,SSK2,SSK3,SSX2,SSX4,STP,STS,SWX2,SWX4,SW2,SX,SXS4,SX4,SX7,VEE1,VET,WDJ,WJ,WJP,WJP1,WKD6,WKT2,WKT4,WKT6,WME2
18	16594-883-010	HOLDER, WIRE .....	1	(1)	-	-	AR,DKR,DS,KR,KRA4,KRF4,KRS4,KRT,KRT4,KRT6,LAJ4,LJ,LJC,LJD2,LJS,LJT,LSJ,LSJ4,LTA,LTJ,LTK1,LTR,LTS,QBU2,QJG2,QLL,QMA8,QME4,QMX2,QSJ,QTC2,QWA4,QXC,QXC9,QXG,QXG2,SAD2,SAJ,SAJ4,SCJ,SG24,SJ,SJC,SJC1,SJC5,SJD2,SKJ,SKR,SMA7,SMJ,SMW2,STP,STS,VEE1,VET,WDJ,WJ,WJP,WJP1,WKD6,WKT2,WKT4,WKT6,WME2
			1	-	-	2423948	SSK1
			2	-	-		SM11,SM12,SM14
			2	-	-	3230227	QB26
19	16599-ZG1-M10	COLLAR, STOPPER .....	(1)	(1)	-	-	HHQ4,HX4,KRT4,LAJ4,LD4,LEH4,LHQ4,LSJ4,LX4,QE,QEH,QHQ4,QLL,QMA4,QMA8,QME4,QPU,QWA4,QX4,QX7,RD4,RHC,RHQ4,RX4,SAJ4,SD4,SE,SG24,SHQ4,SMA7,SXS4,SX4,SX7,TX4,VX4,VX7,WKT4,WMA3,WM1
20	16727-705-000	END, LOCK .....	1	-	-	3093871	VEE1
			-	(1)	-	-	
21	16729-705-010	WIRE, LOCK .....	1	-	-	3093871	VEE1
			-	(1)	-	-	
22	90013-883-000	BOLT, FLANGE, 6X12(CT200) ...	1	-	-	-	AR,DKR,DS,HH,HHQ4,HTF2,HT2,HX,HXQ,HXU,HX2,HX26,HX4,KR,KRA4,KRF4,KRS4,KRT,KRT4,KRT6,LAJ4,LD,LDB1,LDB3,LD4,LE,LEH4,LH,LHQ4,LJ,LJC,LJD2,LJS,LJT,LSJ,LSJ4,LTA,LTJ,LTK1,LTR,LTS,LW2,LX,LXU,LX2,LX26,LX4,PH,PM,PM2,PX,PX2,QA,QAA2,QA2,QA26,QBU2,QB26,QD,QE,QEH,QH,QHQ4,QH2,QH26,QJG2,QJW1,QLL,QM,QMA4,QMA8,QME4,QMH,QMX2,QPU,QSJ,QT,QTC2,QWA4,QX,QXC,QXC9,QXG,QXG2,QXQ,QXS,QXS2,QXU,QX2,QX26,QX4,QX7,RD,RD4,RH,RHC,RHQ4,RX,RX4,SAD2,SAJ,SAJ4,SCJ,SD,SDB1,SDB3,SD16,SD4,SE,SG24,SH,SHQ4,SJ,SJC,SJC1,SJC5,SJD2,SKJ,SKR,SMA7,SMJ,SMW2,SM11,SM12,SM14,SN,SSK1,SSK2,SSK3,SSX2,SSX4,STP,STS,SWX2,SWX4,SW2,SX,SXS4,SX4,SX7,TH,TX,TX2,TX26,TX4,UH,UX,UXU,VA,VEE1,VET,VH,VX,VX4,VX7,WDA6,WDJ,WD12,WJ,WJP,WJP1,WJ1,WKD6,WKT2,WKT4,WKT6,WMA3,WME2,WME4,WM1
			1	-	-	3422682	VXU
23	90015-ZE5-010	BOLT, GOVERNOR ARM .....	1	1	1	-	AR,DKR,DS,HH,HHQ4,HTF2,HT2,HX,HXQ,HXU,HX2,HX26,HX4,KR,KRA4,KRF4,KRS4,KRT,KRT4,KRT6,LAJ4,LD,LDB1,LDB3,LD4,LE,LEH4,LH,LHQ4,LJ,LJC,LJD2,LJS,LJT,LSJ,LSJ4,LTA,LTJ,LTK1,LTR,LTS,LW2,LX,LXU,LX2,LX26,LX4,PH,PM,PM2,PX,PX2,QA,QAA2,QA2,QA26,QBU2,QB26,QD,QE,QEH,QH,QHQ4,QH2,QH26,QJG2,QJW1,QLL,QM,QMA4,QMA8,QME4,QMH,QMX2,QPU,QSJ,QT,QTC2,QWA4,QX,QXC,QXC9,QXG,QXG2,QXQ,QXS,QXS2,QXU,QX2,QX26,QX4,QX7,RD,RD4,RH,RHC,RHQ4,RX,RX4,SAD2,SAJ,SAJ4,SCJ,SD,SDB1,SDB3,SD16,SD4,SE,SG24,SH,SHQ4,SJ,SJC,SJC1,SJC5,SJD2,SKJ,SKR,SMA7,SMJ,SMW2,SM11,SM12,SM14,SN,SSK1,SSK2,SSK3,SSX2,SSX4,STP,STS,SWX2,SWX4,SW2,SX,SXS4,SX4,SX7,TH,TX,TX2,TX26,TX4,UH,UX,UXU,VA,VEE1,VET,VH,VX,VX4,VX7,WDA6,WDJ,WD12,WJ,WJP,WJP1,WJ1,WKD6,WKT2,WKT4,WKT6,WMA3,WME2,WME4,WM1
			1	-	-	3422682	VXU
			-	1	1	1	
24	90016-ZE7-W00	SCREW, RECESSED, 5X28 .....	(1)	-	-	-	QLL



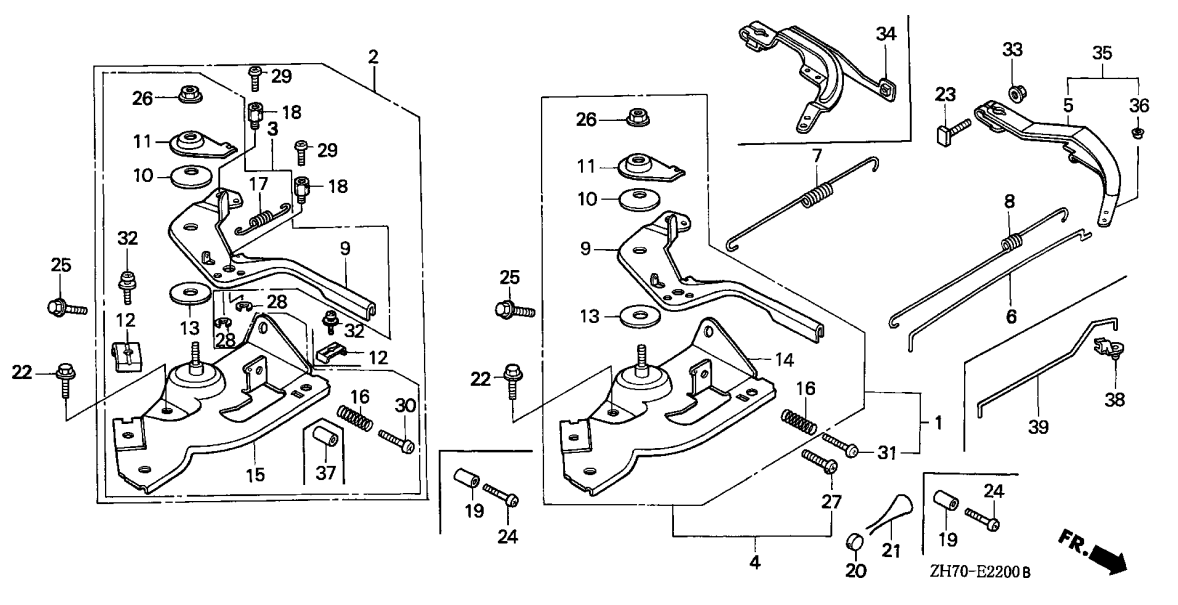

Ref. No.	Part No.	Description	Reqd. QTY				Serial No.	Parts catalogue code
			(1)	(2)	(3)	(4)		
24)	90016-ZG9-N30	SCREW, RECESSED, 5X25	(1)	-	-	-	-----	HHQ4, HX4, KRT4, LAJ4, LD4, LEH4, LHQ4, LSJ4, LX4, QE, QEH, QHQ4, QMA4, QMA8, QME4, QPU, QWA4, QX4, QX7, RD4, RHC, RHQ4, RX4, SAJ4, SD4, SE, SG24, SHQ4, SMA7, SXS4, SX4, SX7, TX4, VX4, VX7, WKT4, WMA3, WM1
25	90022-888-010	BOLT, FLANGE, 6X20(CT200)	1	-	-	-	-----	AR, DKR, DS, HH, HHQ4, HTF2, HT2, HX, HXQ, HXU, HX2, HX26, HX4, KR, KRA4, KRF4, KRS4, KRT, KRT4, KRT6, LAJ4, LD, LDB1, LDB3, LD4, LE, LEH4, LH, LHQ4, LJ, LJC, LJD2, LJS, LJT, LSJ, LSJ4, LTA, LTJ, LTK1, LTR, LTS, LW2, LX, LXU, LX2, LX26, LX4, PH, PM, PM2, PX, PX2, QA, QAA2, QA2, QA26, QBU2, QB26, QD, QE, QEH, QH, QHQ4, QH2, QH26, QJG2, QJW1, QLL, QM, QMA4, QMA8, QME4, QMH, QMX2, QPU, QSJ, QT, QTC2, QWA4, QX, QXC, QXC9, QXG, QXG2, QXQ, QXS, QXS2, QXU, QX2, QX26, QX4, QX7, RD, RD4, RH, RHC, RHQ4, RX, RX4, SAD2, SAJ, SAJ4, SCJ, SD, SDB1, SDB3, SD16, SD4, SE, SG24, SH, SHQ4, SJ, SJC, SJC1, SJC5, SJD2, SKJ, SKR, SMA7, SMJ, SMW2, SM11, SM12, SM14, SN, SSK1, SSK2, SSK3, SSX2, SSX4, STP, STS, SWX2, SWX4, SW2, SX, SXS4, SX4, SX7, TH, TX, TX2, TX26, TX4, UH, UX, UXU, VA, VEE1, VET, VH, VX, VX4, VX7, WDA6, WDJ, WD12, WJ, WJP, WJP1, WJ1, WKD6, WKT2, WKT4, WKT6, WMA3, WME2, WME4, WM1
			1	-	-	-	-----	3422682 VXU
			-	1	1	1		

Ref. No.	Part No.	Description	Reqd. QTY				Serial No.	Parts catalogue code
			(1)	GX120K1 (2)	(3)	(4)		
26	90114-SA0-000	NUT, SELF-LOCK, 6MM .....	1	-	-	-	AR,DKR,DS,HH,HHQ4,HTF2,HT2,HX,HXQ,HXU,HX2,HX26,HX4,KR,KRA4 KRF4,KRS4,KRT,KRT4,KRT6,LAJ4,LD,LDB1,LDB3,LD4,LE,LEH4,LH,LHQ4 LJ,LJC,LJD2,LJS,LJT,LSJ,LSJ4,LTA,LTJ,LTK1,LTR,LTS,LW2,LX,LXU LX2,LX26,LX4,PH,PM,PM2,PX,PX2,QA,QAA2,QA2,QA26,QBU2,QB26,QD,QE QEH,QH,QHQ4,QH2,QH26,QJG2,QJW1,QLL,QM,QMA4,QMA8,QME4,QMH,QMX2 QPU,QSJ,QT,QTC2,QWA4,QX,QXC,QXC9,QXG,QXG2,QXQ,QXS,QXS2,QXU,QX2 QX26,QX4,QX7,RD,RD4,RH,RHC,RHQ4,RX,RX4,SAD2,SAJ,SAJ4,SCJ,SD SDB1,SDB3,SD16,SD4,SE,SG24,SH,SHQ4,SJ,SJC,SJC1,SJC5,SJD2,SKJ SKR,SMA7,SMJ,SMW2,SM11,SM12,SM14,SN,SSK1,SSK2,SSK3,SSX2,SSX4 STP,STS,SWX2,SWX4,SW2,SX,SXS4,SX4,SX7,TH,TX,TX2,TX26,TX4,UH,UX UXU,VA,VEE1,VET,VH,VX,VX4,VX7,WDA6,WDJ,WD12,WJ,WJP,WJP1,WJ1 WKD6,WKT2,WKT4,WKT6,WMA3,WME2,WME4,WM1	
			1	-	-	-	3422682 VXU	
			-	(1)	1	1		
27	90121-ZE0-000	SCREW, LOCK PAN .....	1	-	-	-	3093871 VEE1	
			-	(1)	-	-		
28	90605-230-000	CIRCLIP, 5MM .....	1	-	-	-	AR,DKR,DS,KR,KRA4,KRF4,KRS4,KRT,KRT4,KRT6,LAJ4,LJ,LJC,LJD2,LJS LJT,LSJ,LSJ4,LTA,LTJ,LTK1,LTR,LTS,QBU2,QJG2,QLL,QMA8,QME4,QMX2 QSJ,QTC2,QWA4,QXC,QXC9,QXG,QXG2,SAD2,SAJ,SAJ4,SCJ,SG24,SJ,SJC SJC1,SJC5,SJD2,SKJ,SKR,SMA7,SMJ,SMW2,STP,STS,VEE1,VET,WDJ,WJ WJP,WJP1,WKD6,WKT2,WKT4,WKT6,WME2	
			1	-	-	-	2423948 SSK1	
			2	-	-	-	SM11,SM12,SM14	
			2	-	-	-	3230227 QB26	
			-	(1)	-	-		
29	93500-04006-0H	SCREW, PAN, 4X6 .....	1	-	-	-	AR,DKR,DS,KR,KRA4,KRF4,KRS4,KRT,KRT4,KRT6,LAJ4,LJ,LJC,LJD2,LJS LJT,LSJ,LSJ4,LTA,LTJ,LTK1,LTR,LTS,QBU2,QJG2,QLL,QMA8,QME4,QMX2 QSJ,QTC2,QWA4,QXC,QXC9,QXG,QXG2,SAD2,SAJ,SAJ4,SCJ,SG24,SJ,SJC SJC1,SJC5,SJD2,SKJ,SKR,SMA7,SMJ,SMW2,STP,STS,VEE1,VET,WDJ,WJ WJP,WJP1,WKD6,WKT2,WKT4,WKT6,WME2	
			1	-	-	-	2423948 SSK1	
			2	-	-	-	SM11,SM12,SM14	
			2	-	-	-	3230227 QB26	
			-	(1)	-	-		
30	93500-05025-0H	SCREW, PAN, 5X25 .....	1	-	-	-	AR,DKR,DS,HH,HHQ4,HTF2,HT2,HX,HXQ,HXU,HX2,HX26,HX4,KR,KRA4 KRF4,KRS4,KRT,KRT4,LAJ4,LD,LDB1,LDB3,LD4,LE,LEH4,LH,LHQ4,LJ LJC,LJS,LJT,LSJ,LSJ4,LTA,LTJ,LTK1,LTR,LW2,LX,LXU,LX2,LX26,LX4 PM,PM2,QA,QAA2,QA2,QA26,QBU2,QB26,QD,QE,QEH,QH,QHQ4,QH2,QH26 QJG2,QJW1,QLL,QM,QMA4,QMA8,QME4,QMH,QMX2,QPU,QSJ,QT,QTC2,QWA4 QX,QXC,QXC9,QXG,QXG2,QXQ,QXS,QXS2,QXU,QX2,QX26,QX4,QX7,RD,RD4 RH,RHC,RHQ4,RX,RX4,SAD2,SAJ,SAJ4,SCJ,SD,SDB1,SDB3,SD16,SD4,SE SG24,SH,SHQ4,SJ,SJC,SJC1,SJC5,SKJ,SKR,SMA7,SMJ,SMW2,SM11,SM12 SM14,SN,SSK1,SSK2,SSK3,SSX2,SSX4,STP,STS,SWX2,SWX4,SW2,SX,SXS4 SX4,SX7,VET,WDJ,WJ,WJP,WJP1,WJ1,WKD6,WKT2,WKT4,WKT6,WME2	
			1	-	-	-	3093870 VEE1	
			1	-	-	-	3418989 LJD2	
			-	(1)	1	-		
	90016-ZG9-N30	SCREW, RECESSED, 5X25 .....	1	-	-	-	SJD2	
			1	-	-	-	3418990 LJD2	
	90121-ZE0-000	SCREW, LOCK PAN .....	1	-	-	-	3093871 VEE1	
	93500-05030-0A	SCREW, PAN, 5X30 .....	1	-	-	-	LTS	
31	93500-05025-0H	SCREW, PAN, 5X25 .....	1	-	-	-	WD12	
	93500-05028-0A	SCREW, PAN, 5X28 .....	1	(1)	-	-	2812716 L1,PH,PX,PX2,Q1,TH,TX,TX2,TX26,TX4,UH,UX,VA,VH,VX,VX4,V1,WMA3 W1	
			-	(1)	-	-	H1,R1,S1,U1	



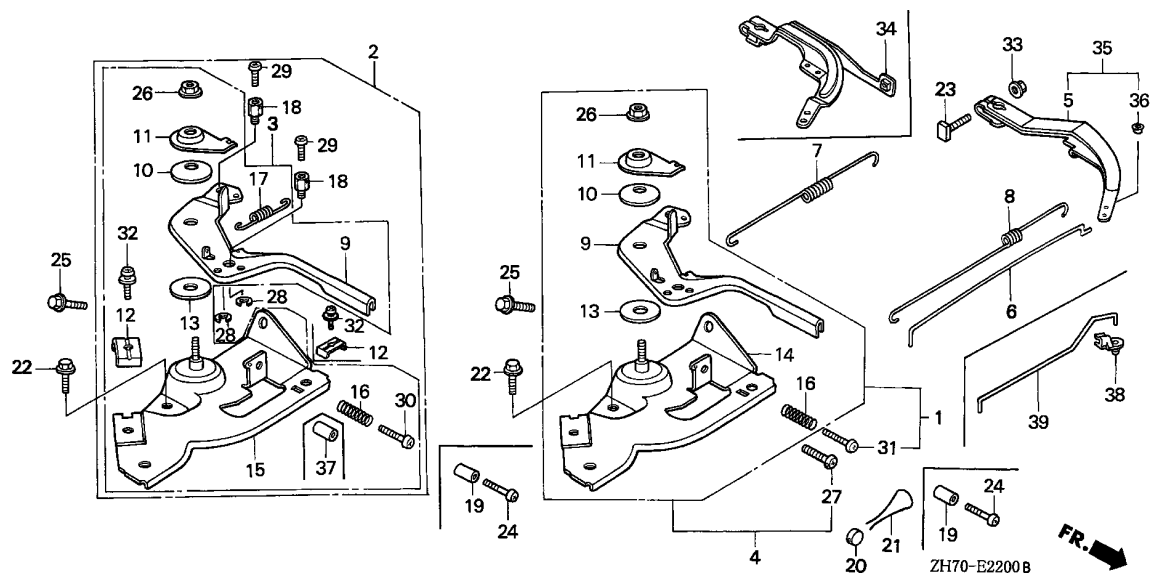

Ref. No.	Part No.	Description	Reqd. QTY				Serial No.	Parts catalogue code
			(1)	(2)	(3)	(4)		
31)	93500-05025-0H	SCREW, PAN, 5X25	1	(1)	-	-	2812717	L1,PH,PX,PX2,Q1,TH,TX,TX2,TX26,TX4,UH,UX,VA,VH,VX,VX4,V1,WMA3 W1
			1	-	-	-		KRT6,UXU,VX7,WDA6,WME4,WM1
			1	-	-	-	3422682	VXU
32	93893-05016-00	SCREW-WASHER, 5X16	1	-	-	1	2308556	HX,HXQ,HX2,LX2,QA,QA2,QH2,QX,QXC,QXG,QXG2,QXQ,QXS,QXS2,QX2
			1	-	-	-	2311704	DS,HH,LD,LE,LH,LJ,LTA,LTJ,LW2,LX,PM,PM2,QD,QE,QEH,QH,QM,QSJ,QT RD,RH,RX,SD,SE,SH,SJ,SKJ,SMJ,SN,STS,SW2,SX,VET,WJ
	93500-05016-0A	SCREW, PAN, 5X16	1	(1)	-	-	2311704	AR,DKR,HHQ4,HTF2,HT2,HXU,HX26,HX4,KR,KRA4,KRF4,KRS4,KRT,KRT4 KRT6,LAJ4,LDB1,LDB3,LD4,LEH4,LHQ4,LJC,LJD2,LJS,LJT,LSJ,LSJ4 LTK1,LTR,LTS,LXU,LX26,LX4,QAA2,QA26,QBU2,QHQ4,QH26,QJG2,QJW1 QLL,QMA4,QMA8,QME4,QMH,QMX2,QPU,QTC2,QWA4,QXC9,QXU,QX26,QX4 QX7,RD4,RHC,RHQ4,RX4,SAD2,SAJ,SAJ4,SCJ,SDB1,SDB3,SD16,SD4,SG24 SHQ4,SJC,SJC1,SJC5,SJD2,SKR,SMA7,SMW2,SSK1,SSK2,SSK3,SSX2,SSX4 STP,SWX2,SWX4,SXS4,SX4,SX7,VEE1,WDJ,WJP,WJP1,WKD6,WKT2,WKT4 WKT6,WME2
			1	-	-	-	2308557	HX,HXQ,HX2,LX2,QA,QA2,QH2,QX,QXC,QXG,QXG2,QXQ,QXS,QXS2,QX2
			1	-	-	-	2311705	DS,HH,LD,LE,LH,LJ,LTA,LTJ,LW2,LX,PM,PM2,QD,QE,QEH,QH,QM,QSJ,QT RD,RH,RX,SD,SE,SH,SJ,SKJ,SMJ,SN,STS,SW2,SX,VET,WJ
			2	-	-	-		QB26,SM11,SM12,SM14
			-	(1)	-	-	2311705	
			-	-	1	-		

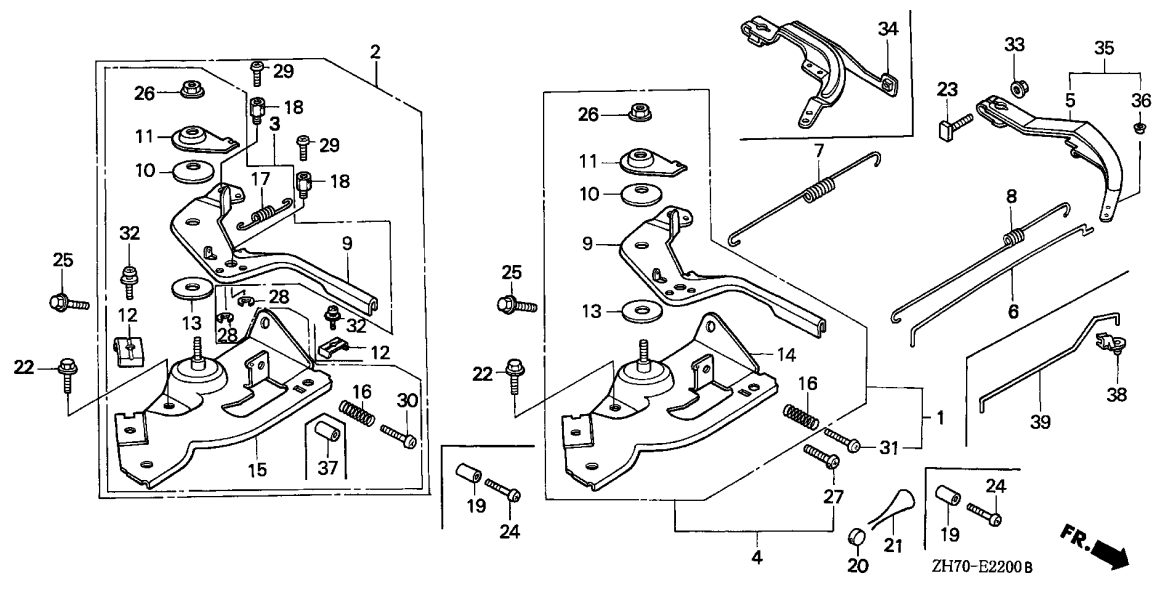

Ref. No.	Part No.	Description	Reqd. QTY				Serial No.	Parts catalogue code
			(1)	(2)	(3)	(4)		
			GX120K1					
			(1)	(2)	(3)	(4)		
33	94050-06000	NUT, FLANGE, 6MM .....	1	-	-	-	-----	AR,DKR,DS,HH,HHQ4,HTF2,HT2,HX,HXQ,HXU,HX2,HX26,HX4,KR,KRA4 KRF4,KRS4,KRT,KRT4,KRT6,LAJ4,LD,LDB1,LDB3,LD4,LE,LEH4,LH,LHQ4 LJ,LJC,LJD2,LJS,LJT,LSJ,LSJ4,LTA,LTJ,LTK1,LTR,LTS,LW2,LX,LXU LX2,LX26,LX4,PH,PM,PM2,PX,PX2,QA,QAA2,QA2,QA26,QBU2,QB26,QD,QE QEH,QH,QHQ4,QH2,QH26,QJG2,QJW1,QLL,QM,QMA4,QMA8,QME4,QMH,QMX2 QPU,QSJ,QT,QTC2,QWA4,QX,QXC,QXC9,QXG,QXG2,QXQ,QXS,QXS2,QXU,QX2 QX26,QX4,QX7,RD,RD4,RH,RHC,RHQ4,RX,RX4,SAD2,SAJ,SAJ4,SCJ,SD SDB1,SDB3,SD16,SD4,SE,SG24,SH,SHQ4,SJ,SJC,SJC1,SJC5,SJD2,SKJ SKR,SMA7,SMJ,SMW2,SM11,SM12,SM14,SN,SSK1,SSK2,SSK3,SSX2,SSX4 STP,STS,SWX2,SWX4,SW2,SX,SXS4,SX4,SX7,TH,TX,TX2,TX26,TX4,UH,UX UXU,VA,VEE1,VET,VH,VX,VX4,VX7,WDA6,WDJ,WD12,WJ,WJP,WJP1,WJ1 WKD6,WKT2,WKT4,WKT6,WMA3,WME2,WME4,WM1
			1	-	-	-	-----	3422682 VXU
34	16550-ZH7-V30	ARM COMP., GOVERNOR (MEIJI) -	1	-	-	-	-----	SJC5,SMJ
35	16550-ZK7-V00	ARM COMP., GOVERNOR .....	1	-	-	-	-----	AR,DKR,KR,KRA4,KRF4,KRT,KRT4,KRT6
36	16552-896-650	COLLAR, LEVER .....	1	-	-	-	-----	AR,DKR,KR,KRA4,KRF4,KRT,KRT4,KRT6
37	16599-ZG1-M10	COLLAR, STOPPER .....	1	-	-	-	-----	SJD2
			1	-	-	-	3418990	LJD2
38	16263-883-W10	JOINT, ROD .....	1	-	-	-	-----	KRS4
39	16555-ZK7-S30	ROD, GOVERNOR .....	1	-	-	-	-----	KRS4





E-22-1

CONTROL(2)

L16

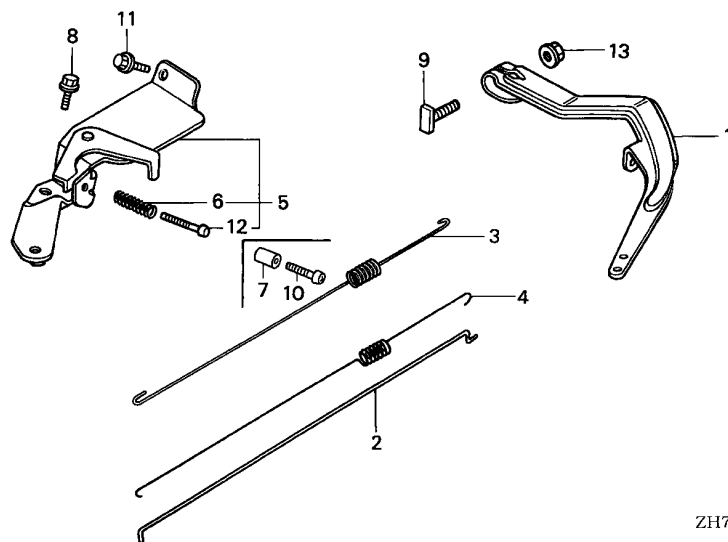

ZH70-E2201



Ref. No.	L.O.N.	(Relative ref. Number) Description	F.R.T.
1	1161A0	ARM, GOVERNOR .....	0.3
2	1161B1	ROD, GOVERNOR .....	0.3
3	1161C5	SPRING, GOVERNOR .....	0.2
4	1161C2	SPRING, THROTTLE RETURN .....	0.3
5	1161D1	CONTROL, THROTTLE/GOVERNOR(A)	0.2

Ref. No.	Part No.	Description	Reqd. QTY				Serial No.	Parts catalogue code
			(1)	(2)	(3)	(4)		
1	16551-ZE0-010	ARM, GOVERNOR .....	1	-	-	-	EN,ET,ETX,VAX4,VED,VED1,VED6,VEX,VEX7,VMS4,VMT,VPR4,VS,VSX VSX1,VS1	
2	16555-ZE0-000	ROD, GOVERNOR .....	1	-	-	-	3422683 ----- VXU	
3	16561-ZE0-020	SPRING, GOVERNOR .....	1	-	-	-	3422683 ----- EN,ET,ETX,VAX4,VED,VED1,VED6,VEX,VEX7,VMS4,VMT,VPR4,VS,VSX VSX1,VS1	
4	16562-ZE0-020	SPRING, THROTTLE RETURN .....	1	-	-	-	3422683 ----- VXU	
	16562-ZE1-020	.....	1	-	-	-	EN,ET,ETX,VED,VED1,VED6,VS,VSX,VSX1,VS1	
5	16570-ZB0-000	CONTROL ASSY. ....	1	-	-	-	3422683 ----- VAX4,VEX,VEX7,VMS4,VMT,VPR4	
			1	-	-	-	3422683 ----- EN,ET,ETX,VAX4,VED,VED1,VED6,VEX,VEX7,VMS4,VMT,VPR4,VS,VSX VSX1,VS1	
6	16584-883-300	SPRING, CONTROL ADJUSTING ...	1	-	-	-	3422683 ----- EN,ET,ETX,VAX4,VED,VED1,VED6,VEX,VEX7,VMS4,VMT,VPR4,VS,VSX VSX1,VS1	
7	16599-ZG1-M10	COLLAR, STOPPER .....	(1)	-	-	-	3422683 ----- VXU	
8	90013-883-000	BOLT, FLANGE, 6X12(CT200) ...	1	-	-	-	EN,ET,ETX,VAX4,VED,VED1,VED6,VEX,VEX7,VMS4,VMT,VPR4,VS,VSX VSX1,VS1	
9	90015-ZE5-010	BOLT, GOVERNOR ARM .....	1	-	-	-	3422683 ----- VXU	
			1	-	-	-	EN,ET,ETX,VAX4,VED,VED1,VED6,VEX,VEX7,VMS4,VMT,VPR4,VS,VSX VSX1,VS1	
10	90016-ZG9-N30	SCREW, RECESSED, 5X25 .....	(1)	-	-	-	3422683 ----- VXU	
			(1)	-	-	-	VAX4,VEX,VEX7,VMS4,VMT,VPR4	
11	90022-888-010	BOLT, FLANGE, 6X20(CT200) ...	1	-	-	-	EN,ET,ETX,VED,VED1,VED6,VMT,VPR4,VS,VSX,VSX1,VS1	

E-22-1

CONTROL(2)

M 1

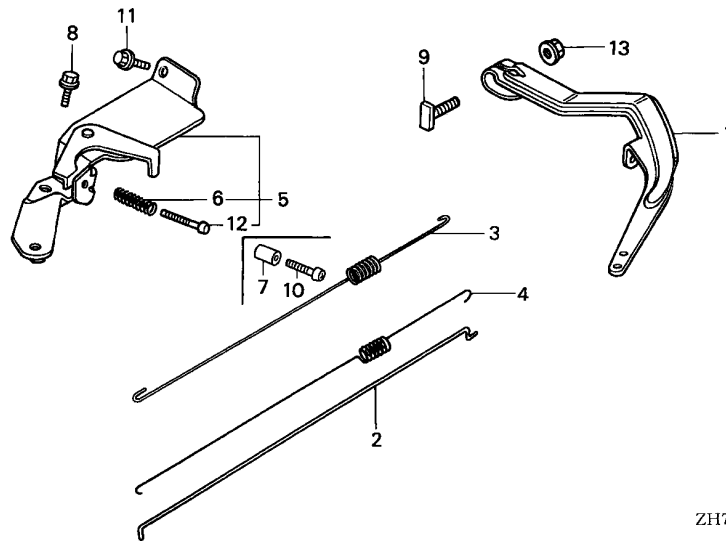

ZH70-E2201

Ref. No.	Part No.	Description	Reqd. QTY				Serial No.	Parts catalogue code
			(1)	(2)	(3)	(4)		
11)	90013-883-000	BOLT, FLANGE, 6X12(CT200) ...	1	-	-	-	VAX4,VEX,VEX7,VMS4	
12	93500-05035-0A	SCREW, PAN, 5X35 .....	1	-	-	3422683	VXU	EN,ET,ETX,VAX4,VED,VED1,VED6,VEX,VEX7,VMS4,VMT,VPR4,VS,VSX
13	94050-06000	NUT, FLANGE, 6MM .....	1	-	-	3422683	VXU	EN,ET,ETX,VAX4,VED,VED1,VED6,VEX,VEX7,VMS4,VMT,VPR4,VS,VSX
			1	-	-	3422683	VXU	VSX1,VS1

2

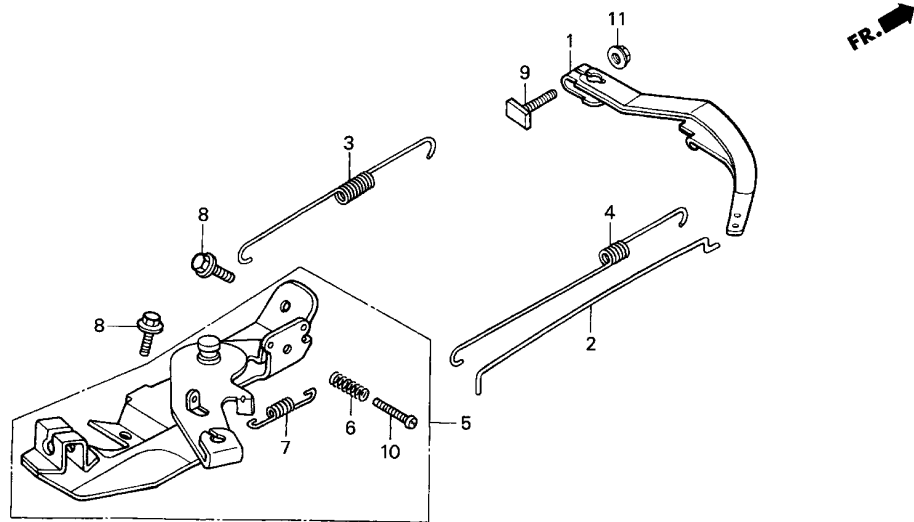

ZH70-E2202

Ref. No.	L.O.N.	(Relative ref. Number) Description	F.R.T.
1	1161A0	ARM, GOVERNOR .....	0.3
2	1161B1	ROD, GOVERNOR .....	0.3
3	1161C5	SPRING, GOVERNOR .....	0.2
4	1161C2	SPRING, THROTTLE RETURN .....	0.3
5	1161A5	CONTROL, THROTTLE/GOVERNOR ...	0.3

Ref. No.	Part No.	Description	Reqd. QTY				Serial No.	Parts catalogue code
			(1)	GX120K1 (2)	(3)	(4)		
1	16551-ZE0-010	ARM, GOVERNOR .....	1	-	-	-	VEK	
2	16555-ZE0-000	ROD, GOVERNOR .....	1	-	-	-	VEK	
3	16561-733-010	SPRING, GOVERNOR .....	1	-	-	-	VEK	
4	16562-ZE0-020	SPRING, THROTTLE RETURN .....	1	-	-	-	VEK	
5	16570-733-000	CONTROL ASSY. ....	1	-	-	-	VEK	
6	16584-883-300	SPRING, CONTROL ADJUSTING ...	1	-	-	-	VEK	
7	16592-ZE1-810	SPRING, CABLE RETURN .....	1	-	-	-	VEK	
8	90013-883-000	BOLT, FLANGE, 6X12(CT200) ...	2	-	-	-	VEK	
9	90015-ZE5-010	BOLT, GOVERNOR ARM .....	1	-	-	-	VEK	
10	93500-05028-0A	SCREW, PAN, 5X28 .....	1	-	-	-	VEK	
11	94050-06000	NUT, FLANGE, 6MM .....	1	-	-	-	VEK	

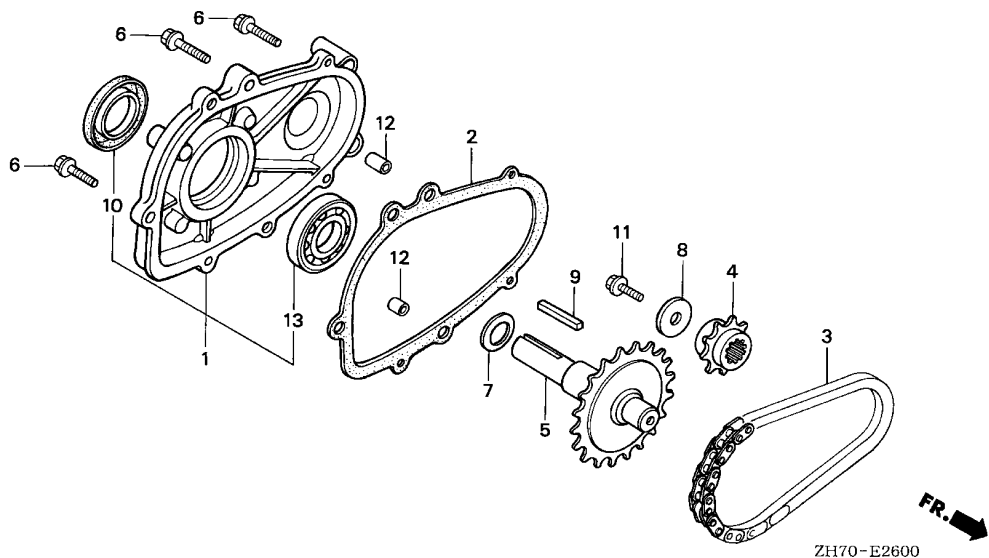

Ref. No.	L.O.N.	(Relative ref. Number) Description	F.R.T.
1		(2)	
1101B2		COVER, CHAIN CASE AND/OR PACKING, CHAIN CASE COVER ...	0.2
3	2141C3	CHAIN, POWER TAKE OFF DRIVE ..	0.3
4	2141J8	SPROCKET, DRIVE .....	0.2
5	2141H4	SHAFT, POWER TAKE OFF .....	0.3
10	2141F2	OIL SEAL, POWER TAKE OFF SHAFT	0.2
13	2141A8	BEARING, POWER TAKE OFF SHAFT	0.3

Ref. No.	Part No.	Description	Reqd. QTY				Serial No.	Parts catalogue code
			(1)	(2)	(3)	(4)		
1	11500-ZE1-610	COVER ASSY., CHAIN CASE .....	1	1	-	-	4222009	DS,KRT,KRT4,KRT6,LAJ4,LD,LH,LHQ4,LJ,LJC,LJD2,LJS,LSJ,LSJ4,LTJ LTK1,LTR,LX,LXU,LX2,LX4,L1
	11500-ZE1-611	.....	1	-	-	-	4222010	LDB1,LDB3,LD4,LE,LEH4,LJT,LTA,LW2,LX26 DS,KRT,KRT4,KRT6,LAJ4,LD,LH,LHQ4,LJ,LJC,LJD2,LJS,LSJ,LSJ4,LTJ LTK1,LTR,LX,LXU,LX2,LX4,L1
2	11521-ZE1-610	PACKING, CHAIN CASE .....	1	(1)	-	-	2272434	LTS DS,H1,LJ,LTA,LW2,Q1,R1,U1,V1,W1
	11521-ZH8-800	PACKING, CHAIN CASE COVER ...	1	(1)	-	-		KRT,KRT4,LAJ4,LD,LDB1,LDB3,LD4,LE,LEH4,LH,LHQ4,LJC,LJD2,LJS LJT,LSJ,LSJ4,LTJ,LTK1,LTR,LTS,LX,LXU,LX2,LX26,LX4,L1
	11521-ZK7-W20	.....	1	(1)	-	-	2272435	DS,H1,LJ,LTA,LW2,Q1,R1,U1,V1,W1
3	14411-ZE0-611	CHAIN, P.T.O. DRIVE (DID270S-DHA-36LE)	1	-	-	-		KRT6
	14411-ZH7-V91	CHAIN, P.T.O. DRIVE (DID270FH DHA-3)	1	-	-	-		DS,LAJ4,LD,LDB1,LDB3,LD4,LE,LEH4,LH,LHQ4,LJ,LJC,LJD2,LJS,LJT LSJ,LSJ4,LTJ,LTK1,LTR,LTS,LW2,LX,LXU,LX2,LX26,LX4,L1
4	23110-ZE0-610	SPROCKET, DRIVE (14T) .....	1	1	-	-		KRT,KRT4,KRT6,LTA
	23110-ZH7-V90	.....	1	-	-	-		DS,LAJ4,LD,LDB1,LDB3,LD4,LE,LEH4,LH,LHQ4,LJ,LJC LJD2,LJS,LJT,LSJ,LSJ4,LTA,LTJ,LTK1,LTR,LTS,LW2,LX,LXU,LX2,LX26 LX4,L1
5	23710-ZE0-613	SHAFT, P.T.O. ....	1	1	-	-		DS
	23710-ZE0-903	.....	1	-	-	-		
6	90015-883-000	BOLT, FLANGE, 6X28 .....	5	5	-	-		DS,KRT,KRT4,LAJ4,LD,LDB1,LDB3,LD4,LE,LEH4,LH,LHQ4,LJ,LJC,LJD2 LJS,LJT,LSJ,LSJ4,LTA,LTJ,LTK1,LTR,LTS,LW2,LX,LXU,LX2,LX26,LX4 L1
	90003-ZK7-W20	.....	5	-	-	-		KRT6



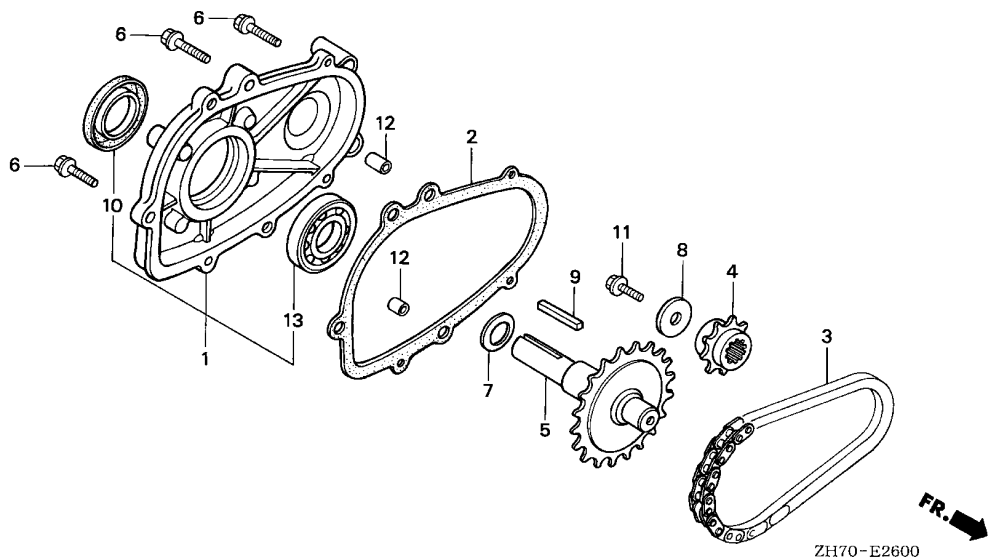

Ref. No.	Part No.	Description	Reqd. QTY				Serial No.	Parts catalogue code
			(1)	(2)	(3)	(4)		
7	90456-ZE1-000	SPRING, THRUST .....	1	1	-	-	DS,KRT,KRT4,KRT6,LAJ4,LD,LDB1,LDB3,LD4,LE,LEH4,LH,LHQ4,LJ,LJC,LJD2,LJS,LJT,LSJ,LSJ4,LTA,LTJ, LTK1,LTR,LTS,LW2,LX,LXU,LX2,LX26 LX4,L1	
8	90471-ZE1-610	WASHER, 8MM .....	1	1	-	-	DS,KRT,KRT4,KRT6,LAJ4,LD,LDB1,LDB3,LD4,LE,LEH4,LH,LHQ4,LJ,LJC,LJD2,LJS,LJT,LSJ,LSJ4,LTA,LTJ, LTK1,LTR,LTS,LW2,LX,LXU,LX2,LX26 LX4,L1	
9	90741-883-810	KEY, 5X5X33(YELLOW) .....	1	(1)	-	-	KRT,KRT4,KRT6,LAJ4,LD,LDB1,LDB3,LD4,LE,LEH4,LH,LHQ4,LJ,LJC,LJD2,LJS,LJT,LSJ,LSJ4,LTA,LTJ, LTK1,LTR,LW2,LX,LXU,LX2,LX26,LX4,L1	
10	91202-883-005	OIL SEAL, 25X41X6 .....	1	1	-	-	4222009 DS,KRT,KRT4,KRT6,LAJ4,LD,LH,LHQ4,LJ,LJC,LJD2,LJS,LSJ,LSJ4,LTJ,LTK1,LTR,LX,LXU,LX2,LX4,L1	
	91201-Z0T-801	.....	1	-	-	-	LDB1,LDB3,LD4,LE,LEH4,LJT,LTA,LW2,LX26	
		.....	1	1	-	-	4222010 DS,KRT,KRT4,KRT6,LAJ4,LD,LH,LHQ4,LJ,LJC,LJD2,LJS,LSJ,LSJ4,LTJ,LTK1,LTR,LX,LXU,LX2,LX4,L1	
		.....	1	-	-	-	LTS	
11	92000-08025-0A	BOLT, HEX., 8X25 .....	1	1	-	-	DS,LD,LE,LH,LJ,LW2,LX,LXU,L1	
	92101-08025-0A	.....	1	-	-	-	KRT,KRT4,KRT6,LAJ4,LDB1,LDB3,LD4,LEH4,LHQ4,LJC,LJD2,LJS,LJT,LSJ,LSJ4,LTA,LTJ,LTK1,LTR,LTS,LX2,LX26,LX4	
12	94301-08140	DOWEL PIN, 8X14 .....	2	2	-	-	DS,KRT,KRT4,KRT6,LAJ4,LD,LDB1,LDB3,LD4,LE,LEH4,LH,LHQ4,LJ,LJC,LJD2,LJS,LJT,LSJ,LSJ4,LTA,LTJ, LTK1,LTR,LTS,LW2,LX,LXU,LX2,LX26 LX4,L1	
13	96100-62050-00	BEARING, RADIAL BALL, 6205 ..	1	1	-	-	DS,KRT,KRT4,KRT6,LAJ4,LD,LDB1,LDB3,LD4,LE,LEH4,LH,LHQ4,LJ,LJC,LJD2,LJS,LJT,LSJ,LSJ4,LTA,LTJ, LTK1,LTR,LTS,LW2,LX,LXU,LX2,LX26 LX4,L1	

E-26-1

REDUCTION(1/2)

M 5

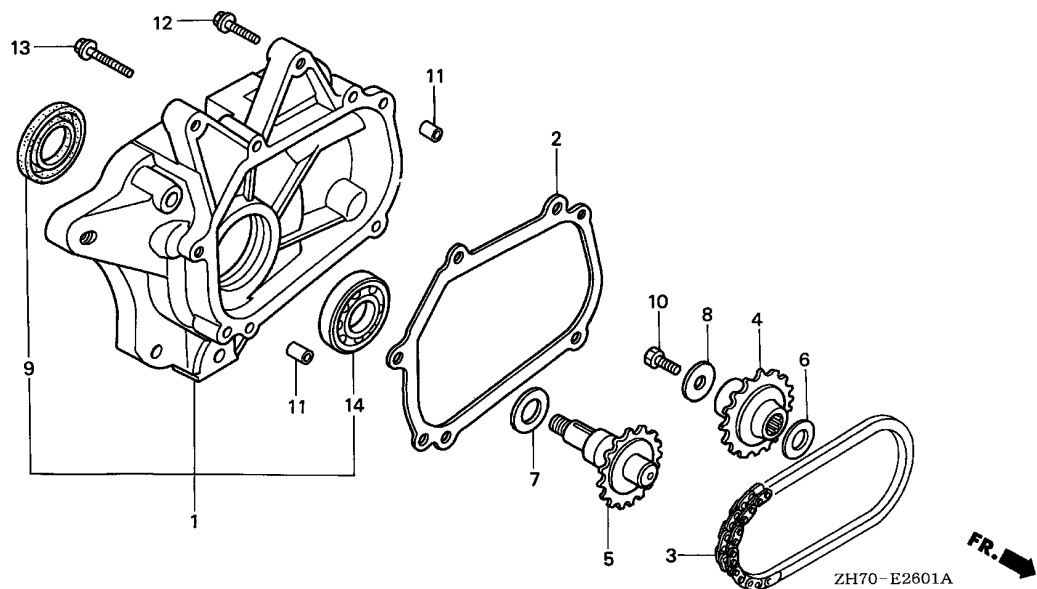

Ref. No.	L.O.N.	(Relative ref. Number) Description	F.R.T.
1		(2) COVER, CHAIN CASE AND/OR PACKING, CHAIN CASE COVER ...	0.2
3	2141C3	CHAIN, POWER TAKE OFF DRIVE ..	0.3
4	2141J8	SPROCKET, DRIVE .....	0.2
5	2141H4	SHAFT, POWER TAKE OFF .....	0.3
9	2141F2	OIL SEAL, POWER TAKE OFF SHAFT	0.2
14	2141A8	BEARING, POWER TAKE OFF SHAFT	0.3

Ref. No.	Part No.	Description	Reqd. QTY				Serial No.	Parts catalogue code
			(1)	(2)	(3)	(4)		
1	11500-ZK7-V00	COVER ASSY., CHAIN CASE .....	1	-	-	-	AR,DKR,KR,KRA4,KRF4,KRS4	
2	11521-ZK7-V00	PACKING, CHAIN CASE COVER ...	1	-	-	-	AR,DKR,KR,KRA4,KRF4,KRS4	
3	14411-ZK7-V01	CHAIN, P.T.O. DRIVE .....	1	-	-	-	AR,DKR,KR,KRA4,KRF4,KRS4	
4	23121-ZK7-V00	SPROCKET, DRIVE (17T) .....	1	-	-	-	AR,DKR,KR,KRA4,KRF4,KRS4	
5	23151-ZK7-V00	SHAFT, P.T.O. ....	1	-	-	-	AR,DKR,KR,KRA4,KRF4,KRS4	
6	90454-428-000	WASHER, THRUST, 20X1.00 .....	1	-	-	-	AR,DKR,KR,KRA4,KRF4,KRS4	
7	90456-ZE1-000	SPRING, THRUST .....	1	-	-	-	AR,DKR,KR,KRA4,KRF4,KRS4	
8	90471-ZE1-610	WASHER, 8MM .....	1	-	-	-	AR,DKR,KR,KRA4,KRF4,KRS4	
9	91252-888-003	OIL SEAL, 25X38X7(ARAI) .....	1	-	-	-	AR,DKR,KR,KRA4,KRF4,KRS4	
10	92101-08025-0A	BOLT, HEX., 8X25 .....	1	-	-	-	AR,DKR,KR,KRA4,KRF4,KRS4	
11	94303-08140	DOWEL PIN, 8X14 .....	2	-	-	-	AR,DKR,KR,KRA4,KRF4,KRS4	
12	95701-08035-00	BOLT, FLANGE, 8X35 .....	4	-	-	-	AR,DKR,KR,KRA4,KRF4,KRS4	
13	95701-08055-00	BOLT, FLANGE, 8X55 .....	1	-	-	-	AR,DKR,KR,KRA4,KRF4,KRS4	
14	96100-60050-00	BEARING, RADIAL BALL, 6005 ..	1	-	-	-	AR,DKR,KR,KRA4,KRF4,KRS4	

2

E-26-2

REDUCTION(1/2)(WITH CLUTCH)

M 6

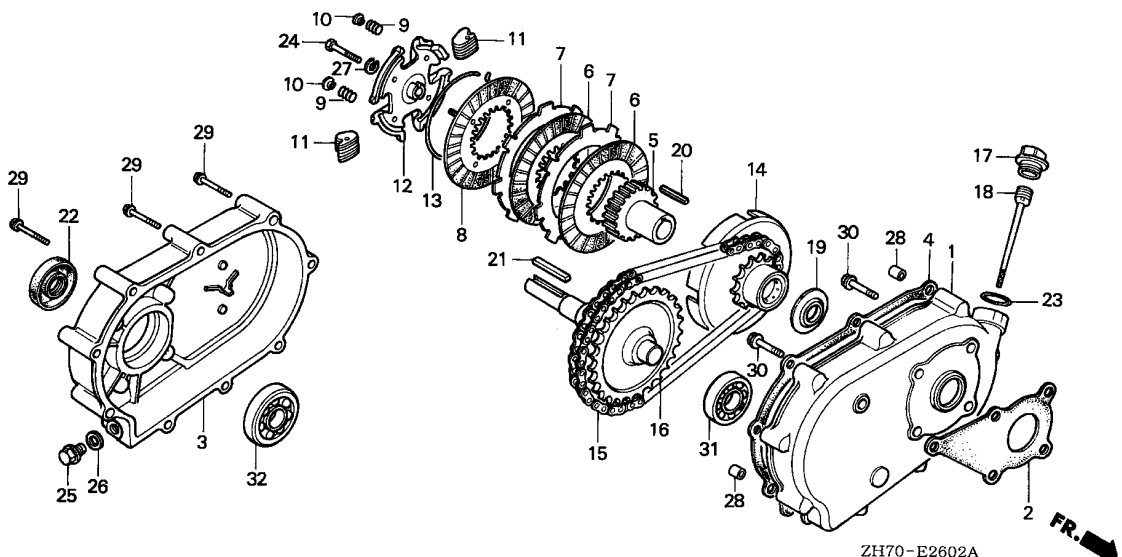

Ref. No.	L.O.N.	(Relative ref. Number) Description	F.R.T.
1		(2,4)	
1	2141C1	CASE, REDUCTION .....	0.3
3	2141D0	COVER, REDUCTION AND/OR PACKING, REDUCTION COVER ....	0.3
6		(7)	
6	2101G4	DISC, CLUTCH FRICTION .....	0.3
8	2101U7	PLATE, CLUTCH PRESSURE .....	0.3
16	2141H4	SHAFT, POWER TAKE OFF .....	0.3
22	2141L3	OIL SEAL, POWER TAKE OFF SHAFT (A) .....	0.3
31	2141A7	BEARING, POWER TAKE OFF SHAFT :FRONT .....	0.4
32	2141L0	BEARING, POWER TAKE OFF SHAFT :REAR .....	0.4

ZH70-E2602A

Ref. No.	Part No.	Description	Reqd. QTY				Serial No.	Parts catalogue code
			(1)	(2)	(3)	(4)		
1	21510-883-621	CASE, REDUCTION .....	1	1	-	-	RD, RD4, RH, RHC, RHQ4, RX, RX4, R1	
2	21591-ZH8-620	PACKING, REDUCTION CASE .....	1	1	-	-	RD, RD4, RH, RHC, RHQ4, RX, RX4, R1	
3	21610-822-611	COVER, REDUCTION .....	1	1	-	-	RD, RD4, RH, RHC, RHQ4, RX, RX4, R1	
4	21691-ZH8-800	PACKING, REDUCTION COVER .....	1	1	-	-	RD, RD4, RH, RHC, RHQ4, RX, RX4, R1	
5	22121-887-620	CENTER, CLUTCH .....	1	1	-	-	RD, RD4, RH, RHC, RHQ4, RX, RX4, R1	
6	22201-822-610	DISK, CLUTCH FRICTION .....	2	2	-	-	RD, RD4, RH, RHC, RHQ4, RX, RX4, R1	
7	22311-822-610	PLATE, CLUTCH .....	2	2	-	-	RD, RD4, RH, RHC, RHQ4, RX, RX4, R1	
8	22350-822-610	PLATE COMP., CLUTCH PRESSURE .....	1	1	-	-	RD, RD4, RH, RHC, RHQ4, RX, RX4, R1	
9	22411-822-611	SPRING, CLUTCH FREE .....	4	4	-	-	RD, RD4, RH, RHC, RHQ4, RX, RX4, R1	
10	22421-822-610	HOLDER, CLUTCH SPRING .....	4	4	-	-	RD, RD4, RH, RHC, RHQ4, RX, RX4, R1	
11	22521-822-610	WEIGHT, CLUTCH .....	48	48	-	-	RD, RD4, RH, RHC, RHQ4, RX, RX4, R1	
12	22531-887-620	HOLDER, CLUTCH WEIGHT .....	1	1	-	-	RD, RD4, RH, RHC, RHQ4, RX, RX4, R1	
13	22535-822-610	CENTER, CLUTCH WEIGHT .....	1	1	-	-	RD, RD4, RH, RHC, RHQ4, RX, RX4, R1	
14	23120-883-620	SPROCKET COMP., DRIVE .....	1	1	-	-	RD, RD4, RH, RHC, RHQ4, RX, RX4, R1	
15	23161-822-610	CHAIN, DRIVE .....	1	1	-	-	2174980 RD, RH, RX, R1	
	23161-822-611	CHAIN, DRIVE (RK428SH-36LE) .....	1	1	-	-	2174981 RD, RH, RX, R1	
			1	-	-	-	RD4, RHC, RHQ4, RX4	
16	23711-822-610	SHAFT COMP., P.T.O. (28T) ...	1	1	-	-	RD, RD4, RH, RHC, RHQ4, RX, RX4, R1	
17	25620-805-611	CAP, REDUCTION OIL (BLACK) ..	1	1	-	-	RD, RD4, RH, RHC, RHQ4, RX, RX4, R1	
	25620-805-612	CAP, REDUCTION OIL (GRAY) ...	1	1	-	-	RD, RD4, RHC, RHQ4, RX, RX4, R1	
18	25651-883-621	GAUGE, OIL LEVEL .....	1	1	-	-	RD, RD4, RH, RHC, RHQ4, RX, RX4, R1	
19	90403-887-620	WASHER, THRUST, 18MM .....	1	1	-	-	RD, RD4, RH, RHC, RHQ4, RX, RX4, R1	
20	90741-883-621	KEY, 5MM .....	1	1	-	-	RD, RD4, RH, RHC, RHQ4, RX, RX4, R1	
21	90741-889-810	KEY, 7X7X33(YELLOW) .....	1	1	-	-	RD, RD4, RH, RHC, RHQ4, RX, RX4, R1	
22	91202-805-610	OIL SEAL (PJ30507) .....	1	1	-	-	RD, RD4, RH, RHC, RHQ4, RX, RX4, R1	

2

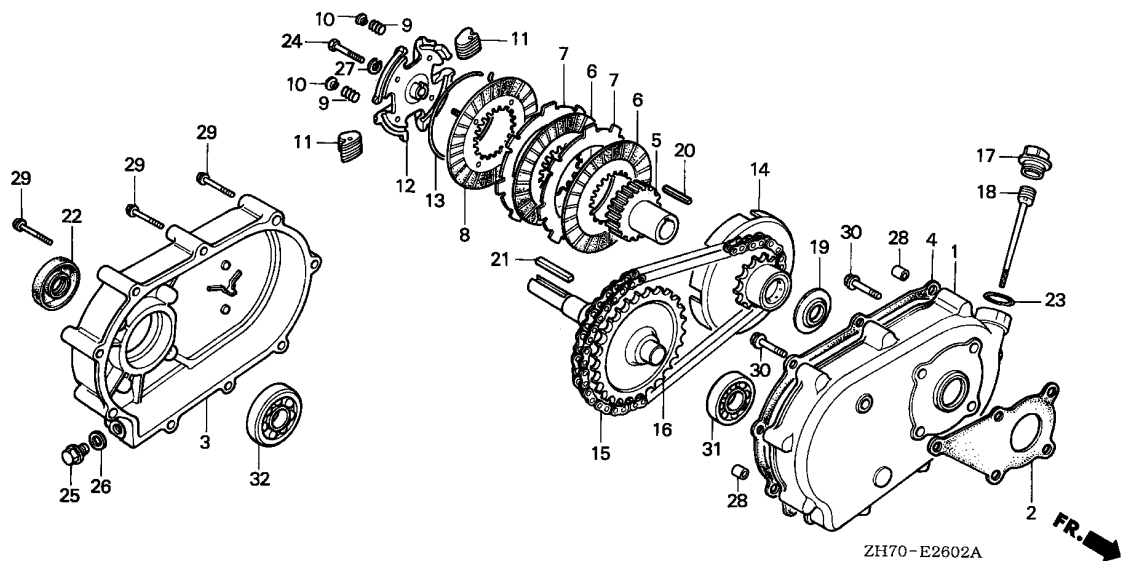

Ref. No.	Part No.	Description	Reqd. QTY				Serial No.	Parts catalogue code
			(1)	(2)	(3)	(4)		
23	91301-805-000	O-RING, 26X2.7	1	1	-	-	RD, RD4, RH, RHC, RHQ4, RX, RX4, R1	
24	92000-08035-0A	BOLT, HEX., 8X35	1	1	-	-	RD, RH, RX, R1	
	92101-08035-0A		1	-	-	-	RD4, RHC, RHQ4, RX4	
25	92800-12000	BOLT, DRAIN PLUG, 12MM	1	1	-	-	RD, RD4, RH, RHC, RHQ4, RX, RX4, R1	
26	94109-12000	WASHER, DRAIN PLUG, 12MM	1	1	-	-	RD, RD4, RH, RHC, RHQ4, RX, RX4, R1	
27	94111-08000	WASHER, SPRING, 8MM	1	1	-	-	RD, RD4, RH, RHC, RHQ4, RX, RX4, R1	
28	94301-08100	DOWEL PIN, 8X10	2	2	-	-	RD, RD4, RH, RHC, RHQ4, RX, RX4, R1	
29	95700-06055-00	BOLT, FLANGE, 6X55	9	9	-	-	RD, RH, RX, R1	
	95701-06055-00		9	-	-	-	RD4, RHC, RHQ4, RX4	
30	95700-08022-00	BOLT, FLANGE, 8X22	5	5	-	-	RD, RH, RX, R1	
	95701-08022-00		5	-	-	-	RD4, RHC, RHQ4, RX4	
31	96100-62050-00	BEARING, RADIAL BALL, 6205	1	1	-	-	RD, RD4, RH, RHC, RHQ4, RX, RX4, R1	
32	96100-62060-00	BEARING, RADIAL BALL, 6206	1	1	-	-	RD, RD4, RH, RHC, RHQ4, RX, RX4, R1	



E-26-3

REDUCTION(1/6)

M 8

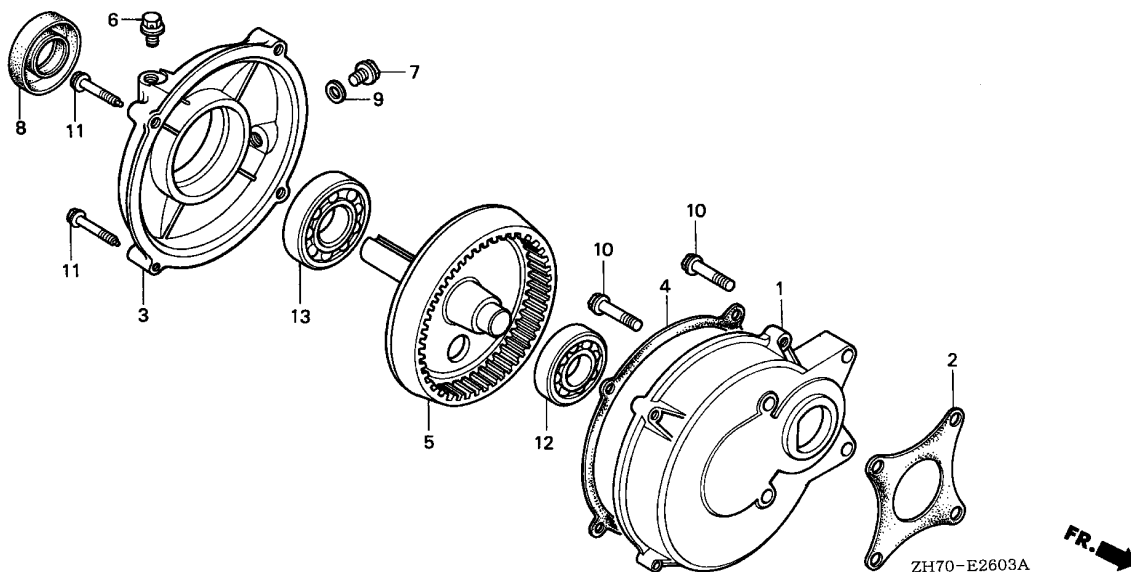

Ref. No.	L.O.N.	(Relative ref. Number) Description	F.R.T.
1		(2)	
2141L8		CASE, REDUCTION(A) .....	0.2
3		(4)	
2141L9		COVER, REDUCTION AND/OR PACKING, REDUCTION COVER(A) .	0.2
5	2141M0	SHAFT, POWER TAKE OFF(A) .....	0.2
8	2141F2	OIL SEAL, POWER TAKE OFF SHAFT	0.2
12	2141L6	BEARING, POWER TAKE OFF SHAFT (A) :FRONT .....	0.3
13	2141L7	BEARING, POWER TAKE OFF SHAFT (A) :REAR .....	0.3

Ref. No.	Part No.	Description	Reqd. QTY				Serial No.	Parts catalogue code
			(1)	(2)	(3)	(4)		
1	21521-883-741	CASE, REDUCTION .....	1	1	-	-	HH,HHQ4,HTF2,HT2,HX,HXQ,HXU,HX2,HX26,HX4,H1	
2	21591-ZH8-740	PACKING, REDUCTION CASE .....	1	1	-	-	HH,HHQ4,HTF2,HT2,HX,HXQ,HXU,HX2,HX26,HX4,H1	
3	21621-883-741	COVER, REDUCTION .....	1	1	-	-	Q1,R1,U1,V1,W1	
4	21692-ZH8-800	PACKING, REDUCTION COVER .....	1	1	-	-	HH,HHQ4,HTF2,HT2,HX,HXQ,HXU,HX2,HX26,HX4,H1	
5	23710-883-740	SHAFT, P.T.O. ....	1	1	-	-	Q1,R1,U1,V1,W1	
6	90002-883-740	BOLT, BREATHING .....	1	1	-	-	HH,HHQ4,HTF2,HT2,HX,HXQ,HXU,HX2,HX26,HX4,H1	
7	90131-883-000	BOLT, DRAIN PLUG, 12X15 .....	1	1	-	-	HH,HHQ4,HTF2,HT2,HX,HXQ,HXU,HX2,HX26,HX4,H1	
8	91202-883-005	OIL SEAL, 25X41X6 .....	1	1	-	-	HH,HHQ4,HTF2,HT2,HX,HXQ,HXU,HX2,HX26,HX4,H1	
9	94109-12000	WASHER, DRAIN PLUG, 12MM .....	1	1	-	-	HH,HHQ4,HTF2,HT2,HX,HXQ,HXU,HX2,HX26,HX4,H1	
10	95700-08032-08	BOLT, FLANGE, 8X32 .....	4	4	-	-	HH,HX,HXU,H1	
	95701-08032-08	.....	4	-	-	-	HHQ4,HTF2,HT2,HXQ,HX2,HX26,HX4	
11	95700-08035-00	BOLT, FLANGE, 8X35 .....	4	4	-	-	HH,HX,HXU,H1	
	95701-08035-00	.....	4	-	-	-	HHQ4,HTF2,HT2,HXQ,HX2,HX26,HX4	
12	96100-62040-00	BEARING, RADIAL BALL, 6204 ..	1	1	-	-	HH,HHQ4,HTF2,HT2,HX,HXQ,HXU,HX2,HX26,HX4,H1	
13	96100-63050-00	BEARING, RADIAL BALL, 6305 ..	1	1	-	-	HH,HHQ4,HTF2,HT2,HX,HXQ,HXU,HX2,HX26,HX4,H1	

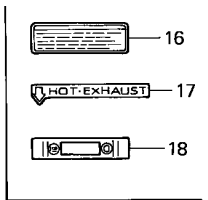
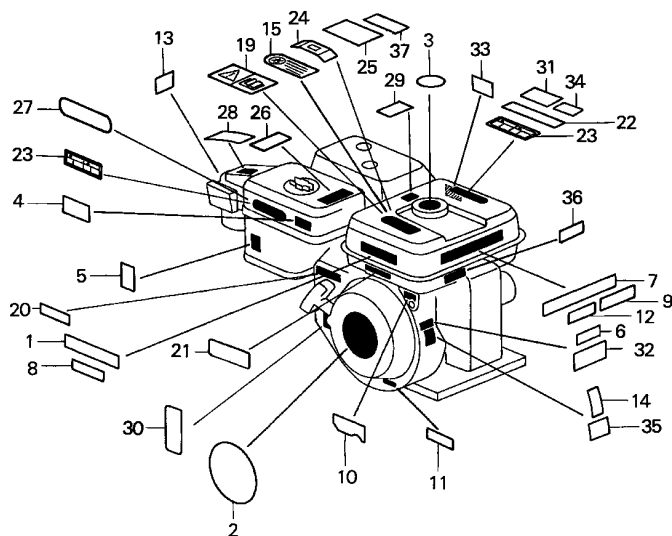

ZH70-E2800C

Ref. L.O.N. (Relative ref. Number) F.R.T.  
No. Description

NO INFORMATION .....

Ref. No.	Part No.	Description	Reqd. QTY				Serial No.	Parts catalogue code
			(1)	(2)	(3)	(4)		
1	87101-733-000	MARK, TOP .....	1	-	1	-	DS, HX, LD, LJ, LX, PH, PX, QD, QSJ, QX, RD, RX, SD, SJ, SMJ, SN, STS, SX, TH, UH, UIH, UX, VET, VH, VX, WIH1, WJ	
	87516-733-C20	LABEL, OPERATOR WARNING (FRENCH)	-	(1)	-	-	2476407 QE	
	87522-ZH9-000	LABEL, CAUTION .....	1	(1)	-	-	HH, HXQ, H1, LDB1, LDB3, LE, LW2, L1, PM2, QAA2, QA26, QBU2, QH2, QMH, QXC, QXG, QXQ, QXS, RH, R1, SAD2, SDB1, SDB3, SSK1, SSK2, SW2, S1, U1, VA, VH, VS, VS1, V1, WJ, W1	
			1	-	-	-	2476407 QE, QLL, QPU, SE, VEX	
			1	-	-	-	3070123 LJD2	
	87522-ZH9-820	LABEL, CAUTION (THAI) .....	1	-	1	-	QIH1, QT	
			-	(1)	-	-		
	87525-ZH7-000	EMBLEM, UPPER (INTERNAL) .....	-	(1)	-	-		
	87525-ZH7-810	EMBLEM, UPPER (EXTERNAL) .....	-	(1)	-	-		
	87528-ZE0-900	MARK, ENGINE OPERATION (J) ..	1	-	-	-	STP	
			1	-	-	2119400	STS	
	87522-ZH9-010	LABEL, CAUTION .....	1	(1)	-	-	AR, HTF2, HT2, HX, HXU, HX2, HX26, KRS4, LD, LH, LX, LXU, LX2, LX26, PH, PM, PX, PX2, QA, QA2, QD, QH, QH26, QJG2, QM, QMX2, QTC2, QWA4, QX, QXC9, QXG2, QXS2, QXU, QX2, QX26, Q1, RD, RX, SD, SD16, SG24, SH, SMW2, SM12, SSS2, SWX2, SX, SXS4, TH, TX, TX2, TX26, UH, UX, UXU, VED, VED1, VED6, VSX, VSX1, VX, VXU, WDA6, WD12, WKD6, WKT2, WKT6, WME2	
2	87521-770-880	PLATE, EMBLEM .....	1	-	-	-	LEH4, QE	
	87521-ZH7-000	EMBLEM (INTERNAL) .....	1	-	-	-	2185869 DS, LJ, QSJ, SJ, SMJ, STS, VET, WJ	
			-	(1)	-	-	2185869	



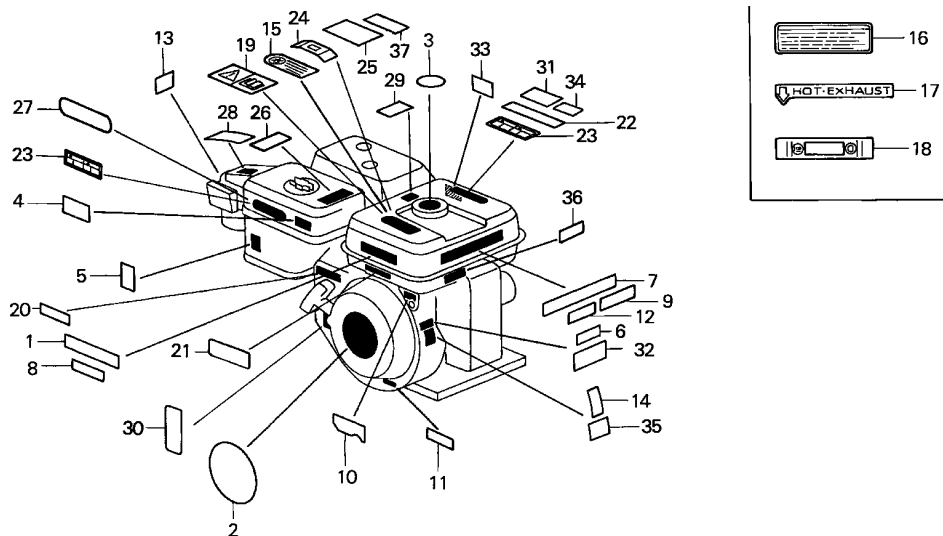

ZH70-E2800C



Ref. No.	Part No.	Description	Reqd. QTY				Serial No.	Parts catalogue code	
			(1)	(2)	(3)	(4)			
(2)	87521-ZH7-010	EMBLEM .....	1	(1)	-	-	2185870	EN,ET,ETX,HH,LE,LW2,L1,PM2,QE,QSJ,QXC,QXG,QXS,RH,SW2,U1,VA,VH VS,V1,W1	
			1	(1)	-	-	2185870	3841370 DS,HX,H1,LD,LH,LJ,LX,PH,PM,PX,QA,QD,QH,QM,QX,Q1,RD,RX,R1,SD,SE SH,SJ,SMJ,STS,SX,S1,TH,TX,UH,UX,VED,VED1,VET,VSX,VX,WJ	
			1	-	1	-	-	-	HXQ,LDB1,LDB3,LD4,LJT,LTA,QAA2,QA26,QBU2,QH2,QJW1,QMH,QPU,QXQ SAD2,SDB1,SDB3,SSK1,SSK2,UIH,VAX4,VS1,WDJ,WJ1
			1	-	-	-	-	3841370	AR,DKR,HHQ4,HTF2,HXU,HX2,HX26,HX4,KR,KRA4,KRT,KRT4,KRT6,LAJ4 LHQ4,LJC,LJS,LSJ,LSJ4,LTJ,LTK1,LTR,LXU,LX2,LX26,LX4,PX2,QA2 QHQ4,QH26,QJG2,QLL,QMA4,QMA8,QME4,QMX2,QTC2,QWA4,QXC9,QXG2 QXS2,QXU,QX2,QX26,QX4,RD4,RHC,RHQ4,RX4,SAJ,SAJ4,SCJ,SD16,SD4 SG24,SHQ4,SJC,SJC1,SJC5,SKJ,SKR,SMA7,SMW2,SSK3,SSX2,SSX4,STP SWX2,SWX4,SXS4,SX4,TX2,TX26,TX4,UXU,VED6,VEE1,VEX,VMS4,VMT VPR4,VSX1,VXU,VX4,WDA6,WD12,WJP,WKD6,WKT2,WKT4,WMA3,WME2,WME4 WM1
	87521-ZH7-810	EMBLEM (EXTERNAL) .....	1	-	-	2185870	2185869 EN,ET,ETX,HH,HX,LD,LE,LH,LW2,LX,PH,PM,PM2,PX,QA,QD,QE,QH,QM,QX QXC,QXG,QXS,RD,RH,RX,SD,SE,SH,SW2,SX,TH,TX,UH,UX,VA,VED,VED1 VH,VS,VSX,VX		
	87521-ZH7-830	EMBLEM (THAI) .....	-	(1)	-	1	2185869	2185869 QT	
	87521-ZH7-831	.....	-	(1)	-	-	2185869	2185869 QT	
	87521-ZH7-831	.....	1	-	-	-	2185870	3463997 QT	
	87521-ZH7-831	.....	-	(1)	-	-	2185870	2185870 QT	
	87521-ZH7-Y10	EMBLEM .....	1	-	1	-	3463998	4142273 QT	

Ref. No.	Part No.	Description	Reqd. QTY				Serial No.	Parts catalogue code
			(1)	GX120K1 (2)	(3)	(4)		
(2)	87521-ZH7-020	EMBLEM .....	1	1	-	-	3841371 4142243	AR,DKR,DS,HHQ4,HTF2,HX,HXU,HX2,HX26,HX4,H1,KR,KRA4,KRT,KRT4,KRT6,LAJ4,LD,LH,LHQ4,LJ,LJC,LJS,LSJ,LSJ4,LTJ,LTK1,LTR,LX,LXU,LX2,LX26,LX4,PH,PM,PX,PX2,QA,QA2,QD,QH,QHQ4,QH26,QJG2,QLL,QM,QMA4,QMA8,QME4,QMX2,QTC2,QWA4,QX,QXC9,QXG2,QXS2,QXU,QX2,QX26,QX4,Q1,RD,RD4,RHC,RHQ4,RX,RX4,R1,SAJ,SAJ4,SCJ,SD,SD16,SD4,SE,SG24,SH,SHQ4,SJ,SJC,SJC1,SJC5,SKJ,SKR,SMA7,SMJ,SMW2,SSK3,SSX2,SSX4,STP,STS,SWX2,SWX4,SX,SXS4,SX4,S1,TH,TX,TX2,TX26,TX4,UH,UX,UXU,VED,VED1,VED6,VEE1,VET,VEX,VMS4,VMT,VPR4,VSX,VSX1,VX,VXU,VX4,WDA6,WD12,WJ,WJP,WKD6,WKT2,WKT4,WMA3,WME2,WME4,WM1
			1	-	-	-	4142243	HT2,KRF4,KRS4,QX7,SM11,SM14,SX7,VEK,VEX7,VX7,WKT6
	87521-ZH7-Y11	.....	-	-	1	-	-----	WIH1
	87521-ZH7-030	EMBLEM (4.0) .....	1	1	-	-	4142274	QT
			1	1	-	-	4142244	AR,DKR,DS,HHQ4,HTF2,HT2,HX,HXU,HX2,HX26,HX4,H1,KR,KRA4,KRF4,KRS4,KRT,KRT4,KRT6,LAJ4,LD,LH,LHQ4,LJ,LJC,LJS,LSJ,LSJ4,LTJ,LTK1,LTR,LX,LXU,LX2,LX26,LX4,PH,PM,PX,PX2,QA,QA2,QD,QH,QHQ4,QH26,QJG2,QLL,QM,QMA4,QMA8,QME4,QMX2,QTC2,QWA4,QX,QXC9,QXG2,QXS2,QXU,QX2,QX26,QX4,QX7,Q1,RD,RD4,RHC,RHQ4,RX,RX4,R1,SAJ,SAJ4,SCJ,SD,SD16,SD4,SE,SG24,SH,SHQ4,SJ,SJC,SJC1,SJC5,SKJ,SKR,SMA7,SMJ,SMW2,SM11,SM14,SSK3,SSX2,SSX4,STP,STS,SWX2,SWX4,SX,SXS4,SX4,SX7,S1,TH,TX,TX2,TX26,TX4,UH,UX,UXU,VED,VED1,VED6,VEE1,VEK,VET,VEX,VEX7,VMS4,VMT,VPR4,VSX,VSX1,VX,VXU,VX4,VX7,WDA6,WD12,WJ,WJP,WKD6,WKT2,WKT4,WKT6,WMA3,WME2,WME4,WM1
3	87522-ZE1-010	LABEL, FUEL WARNING .....	1	-	-	-	-----	LTS,SM12
			1	-	-	-	-----	LTJ
			1	-	-	-	2299911	DS,EN,ET,ETX,LJ,QSJ,SJ,SKJ,SMJ,STS,VET,WJ
			1	-	-	-	2688781	SAJ
	87106-ZH8-S00	MARK, FUEL CAUTION (SHJ) ....	-	(1)	-	-	2299936	H1,Q1,R1,U1,V1,W1
	87522-ZE1-810	MARK, CAUTION .....	1	(1)	-	-	2421922	UIH,WIH1
			1	-	1	-	-----	HX,HXQ,HX2,H1,LTJ,LX2,QA,QA2,QH2,QX,QXC,QXG,QXG2,QXQ,QXS,QXS2,QX2,Q1,R1,SCJ,TX,TX2,U1,V1,W1
			1	-	-	-	2400126	LDB1,LDB3,QIH1,SDB1,SDB3
			1	-	-	-	2400126	HH,LD,LE,LH,LW2,LX,PH,PM,PM2,PX,QD,QE,QEH,QH,QLL,QM,QPU,QT,RD,RH,RX,SD,SE,SH,SN,SW2,SX,TH,UH,UX,VA,VED,VED1,VEX,VH,VS,VSX,VSX1,VS1,VX
			1	-	-	-	2299912	2400126 EN,ET,ETX
4	87524-883-690	MARK, AIR CLEANER CAUTION (OIL BATH) (ARABIC) .....	1	-	-	-	2299912	2421922 DS,LJ,QSJ,SJ,SKJ,SMJ,STS,VET,WJ
			1	-	1	-	-----	LW2,QIH1,QT
			-	(1)	-	-	-----	
5	87528-ZB2-630	MARK, CHOKE .....	1	-	-	-	-----	VMT,VPR4
	87528-ZE1-000	.....	1	-	-	-	2299911	DS,LJ,LTA,QSJ,SJ,SKJ,SMJ,VET,WJ
			1	-	-	-	2413831	LTJ
			-	(1)	-	-	2299936	
	87528-ZE1-810	.....	1	-	-	-	-----	AR,EN,ET,ETX,HH,HTF2,HT2,HX,HXQ,HXU,HX2,HX26,KR,KRS4,KRT,KRT6,LD,LDB1,LDB3,LE,LH,LJC,LJS,LJT,LSJ,LTK1,LTR,LTS,LW2,LX,LXU,LX2,LX26,PH,PM,PM2,PX,PX2,QA,QAA2,QA2,QA26,QBU2,QD,QH,QH2,QH26,QJG2,QJW1,QM,QMH,QMX2,QTC2,QX,QXC,QXC9,QXG,QXG2,QXQ,QXS,QXS2,QXU,QX2,QX26,RD,RH,RX,SAD2,SAJ,SCJ,SD,SDB1,SDB3,SD16,SH,SJC,SJC1,SJC5,SKR,SMW2,SM11,SM12,SN,SSK1,SSK2,SSK3,SSX2,STP,SWX2,SW2,SX,TH,TX,TX2,TX26,UH,UX,UXU,VA,VED,VED1,VED6,VEE1,VH,VS,VSX,VSX1,VS1,VX,VXU,WDA6,WDJ,WD12,WJP,WJP1,WJ1,WKD6,WKT2,WKT6,WME2
			1	-	-	-	2299912	DS,LJ,LTA,QSJ,SJ,SKJ,SMJ,VET,WJ
			1	-	-	-	2413832	LTJ
			1	-	-	-	2476407	QE,QLL,QPU,RHC,SE,VEX
			1	-	-	-	3418989	LJD2
			-	(1)	-	1		



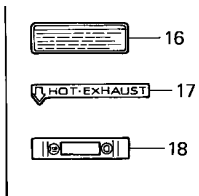
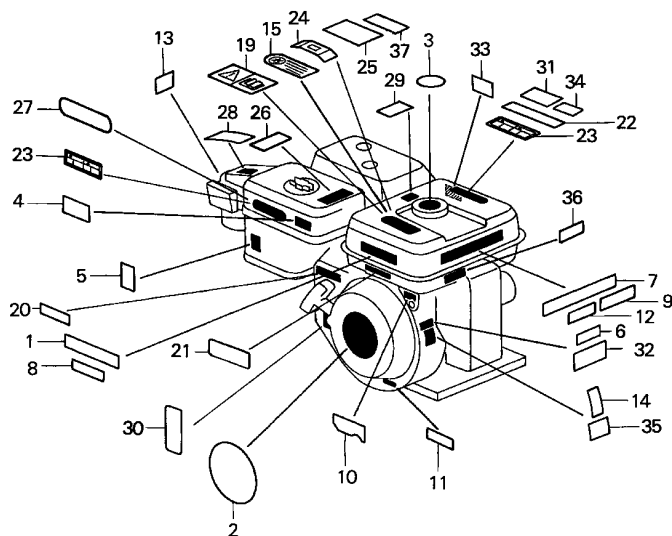

ZH70-E2800C

Ref. No.	Part No.	Description	Reqd. QTY				Serial No.	Parts catalogue code	
			(1)	(2)	(3)	(4)			
(5)	87528-ZE1-690	MARK, CHOKE (THAI)	1	-	1	-	-----	QIH1,QT	
	87528-ZH8-S00	MARK, CHOKE	-	(1)	-	-	-----	UIH,WIH1	
	87528-733-E90	MARK, CHOKE (H=36)	1	-	-	-	-----	HHQ4, HX4, KRA4, KRF4, KRS4, KRT4, LAJ4, LD4, LEH4, LHQ4, LSJ4, LX4, QEH, QHQ4, QMA4, QMA8, QWA4, QX4, QX7, RD4, RHQ4, RX4, SAJ4, SD4, SG24, SHQ4, SJD2, SMA7, SM14, SSX4, SWX4, SXS4, SX4, SX7, TX4, VAX4, VEX7, VMS4, VX4, VX7, WKT4, WMA3, WME4, WM1	
			1	-	-	-	2476408	-----	QE, QLL, QPU, RHC, SE, VEX
			1	-	-	-	2923169	-----	DKR
			1	-	-	-	3418990	-----	LJD2
	87528-777-000	MARK, CHOKE	1	-	-	-	-----	VEK	
6	87150-ZH8-000	MARK, CAUTION (JAPANESE)	1	-	-	-	-----	WJ1	
	87530-ZH7-810	LABEL, SPECIFICATION (EXTERNAL)	1	-	-	-	2299936	EN, ET, ETX, HH, HX, LD, LE, LH, LW2, LX, PH, PM, PM2, PX, QA, QD, QE, QEH, QH, QM, QX, RD, RH, RX, SD, SE, SH, SW2, SX, TH, TX, UH, UX, VA, VED, VED1, VEX, VH, VS, VSX, VSX1, VS1, VX	
			-	(1)	-	-	2299936	-----	
			-	-	-	1	-----		
	87530-ZH7-830	LABEL, SPECIFICATION (THAI)	1	-	-	-	2299936	QT	
			-	(1)	-	-	2299936	-----	
	87530-ZH7-000	LABEL, SPECIFICATION (INTERNAL)	1	(1)	-	-	4070274	H1, L1, R1, SM11	
			-	(1)	-	-	-----	Q1, S1, U1, V1, W1	
	87530-ZH7-820	LABEL, SPECIFICATION (INTERNAL/L-TYPE)	-	(1)	-	-	-----		
	87530-ZH7-010	LABEL, SPECIFICATION	1	(1)	-	-	4070275	H1, L1, R1, SM11	
7	87531-733-C30	EMBLEM (HONDA 120)	1	-	-	-	-----	LEH4, QEH	

Ref. No.	Part No.	Description	Reqd. QTY				Serial No.	Parts catalogue code
			(1)	GX120K1 (2)	(3)	(4)		
8	87520-ZH8-000	MARK A, COMBINATION .....	1	(1)	-	-	2612209	----- DS,H1,LTA,LTJ,QSJ,R1,SCJ,SJ,SJC,SKJ,SMJ,SSK3,STP,STS,VET,WJ WJP
			1	-	-	-	-----	----- KRT,KRT6,LJC,LJS,LJT,LSJ, LTK1,LTR,LTS,QJW1,SJC1,SJC5,SM11,VEE1 WDJ,WJP1
			1	-	-	-	2613594	----- LJ,SAJ
	87532-ZB4-G60	MARK, OIL ALERT (GERMAN) ....	1	-	-	-	2311047	----- VSX
9	87532-ZB4-G60	MARK, OIL ALERT (GERMAN) ....	1	-	-	-	-----	----- HTF2,HXU,HX26,LXU,LX26,PX2,QBU2,QLL,QMX2,QTC2,QXC9,QXU,QX26 SAD2,SMW2, TX26,UXU,VXU,WKT2
			1	-	-	-	2311047	----- HX,HXQ,HX2,LX,LX2,PX,QX,QXC,QXG,QXQ,QXS,QXS2,QX2,RX,SX, TX, TX2 UX,VA,VED,VS1,VX
			1	-	-	-	2311047	2445194 QEH
			1	-	-	-	2311047	2564424 QXG2
			-	(1)	-	-	2311047	-----
	87532-ZB4-H50	MARK, OIL ALERT (FRENCH) ....	1	-	-	-	-----	----- HTF2,HXU,HX26,LXU,LX26,PX2,QBU2,QMX2,QTC2,QXC9,QXU,QX26,SAD2 SMW2, TX26,UXU,VED6,VXU,WKD6,WKT2,WKT6
			1	-	-	-	2311047	----- HX,HXQ,HX2,LX,LX2,PX,QX,QXC,QXG,QXQ,QXS,QXS2,QX2,RX,SX, TX, TX2 UX,VA,VED1,VEX,VSX,VSX1,VX
			1	-	-	-	-----	2476407 QLL
			1	-	-	-	2311047	2564424 QXG2
			-	(1)	-	-	2311047	-----
10	87532-ZE1-810	MARK, OIL ALERT (EXTERNAL) ..	1	-	-	-	-----	2186369 HX,LX,PX,QX,QXC,QXG,QXS,RX,SX, TX,UX,VA,VED1,VSX,VX
			1	-	-	-	-----	2186369
	87532-ZE1-000	MARK, OIL ALERT (INTERNAL) ..	1	(1)	-	-	-----	2186369 H1,Q1,R1,SMJ,U1,V1,W1
11	87532-ZH8-W40	MARK, THROTTLE INDICATION ...	1	-	-	-	-----	----- HHQ4,HX4,KRT4,LAJ4,LD4,LEH4,LHQ4,LSJ4,LX4,QHQ4,QMA4,QMA8,QME4 QX4,QX7,RD4,RHQ4,RX4,SAJ4,SD4,SHQ4,SMA7,SM14,SSX4,SXS4,SX4,SX7 TX4,VX4,VX7,WKT4,WMA3,WME4
			1	-	-	-	2476408	----- QE,QEH,QLL,QPU,RHC,SE,VEX
			1	-	-	-	-----	2618672 VAX4
12	87532-ZH8-000	MARK, OIL ALERT (INTERNAL) ..	1	-	-	-	-----	----- LJC,LTA,QJW1,SJC1,SJC5,VEE1
			1	-	-	-	2186370	----- SMJ
			-	1	-	-	2183670	----- H1,Q1,R1,U1,V1,W1
	87532-ZH8-810	MARK, OIL ALERT (EXTERNAL) ..	1	-	-	-	-----	----- HTF2,HXQ,HXU,HX2,HX26,LXU,LX2,LX26,PX2,QBU2,QMH,QMX2,QTC2,QXC9 QXQ,QXS2,QXU,QX2,QX26,SAD2,SG24,SMW2,SM12,SSX2,SWX2,SXS4, TX2 TX26,UXU,VED6,VXU,WKD6,WKT2,WKT6
			1	-	-	-	2186370	----- HX,LX,PX,QX,QXC,QXG,QXS,RX,SX, TX,UX,VA,VED1,VX
			1	-	-	-	-----	2476407 QLL,VEX
			1	-	-	-	-----	2564424 QXG2
			-	1	-	-	2186370	-----
13	87534-ZE1-000	LABEL, AIR CLEANER CAUTION ..	-	(1)	-	-	-----	----- H1,Q1,R1,U1,V1,W1
	87534-ZE1-841	.....	1	-	-	-	-----	----- QXC
			-	(1)	-	-	-----	-----
14	87530-ZH7-000	LABEL, SPECIFICATION (INTERNAL)	1	(1)	-	-	-----	----- QJW1,QSJ,Q1,SSK2,U1,V1,WDJ,WJ1,W1
			1	(1)	-	-	4070274	H1,R1,SAJ,SCJ,SJ,SJC,SJC1,SJC5,SKJ,SKR,SMJ,SM11,SSK1,SSK3,STP STS,VET,WJ,WJP,WJP1
	87530-ZH7-810	LABEL, SPECIFICATION (EXTERNAL)	1	(1)	-	-	-----	----- 2299936 HX,HXQ,HX2,H1,LD,LX,LX2,PH,PX,QA,QA2,QD,QH2,QX,QXC,QXG,QXG2 QXQ,QXS,QXS2,QX2,Q1,RD,RX,R1,SD,SX,TH, TX, TX2,UH,UX,U1,VH,VX,V1 W1
	87530-ZH7-820	LABEL, SPECIFICATION (INTERNAL/L-TYPE)	1	(1)	-	-	-----	----- H1,LJT,LTA,Q1,R1,U1,V1,W1
			1	-	-	-	4077491	DS,KRT,KRT6,LJ,LJC,LJS,LSJ,LTJ,LTK1,LTR
	87594-ZB3-C00	MARK, OIL CAUTION .....	1	-	-	-	2171486	VS,VSX
	87530-ZH7-010	LABEL, SPECIFICATION .....	1	(1)	-	-	4070275	H1,R1,SAJ,SCJ,SJ,SJC,SJC1,SJC5,SKJ,SKR,SMJ,SM11,SSK1,SSK3,STP STS,VET,WJ,WJP,WJP1



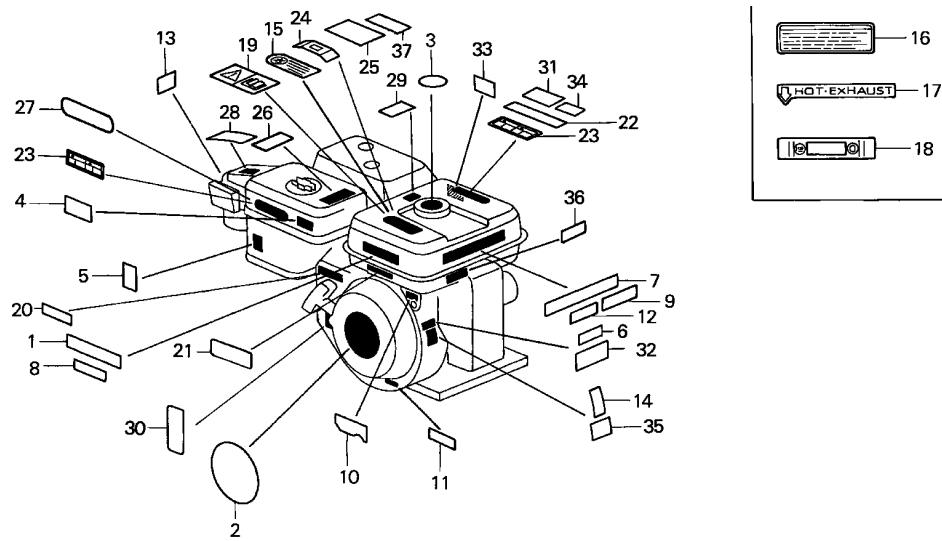

ZH70-E2800C



Ref. No.	Part No.	Description	Reqd. QTY				Serial No.	Parts catalogue code	
			GX120K1						
			(1)	(2)	(3)	(4)			
14)	87530-ZH7-821	LABEL, SPECIFICATION (INTERNAL/L-TYPE)	1	-	-	-	-----	LTS	
			1	-	-	-	4077492	-----	DS,KRT,KRT6,LJ,LJC,LJS,LSJ,LTJ,LTK1,LTR
15	87522-ZB3-K01	MARK, FIRE DANGER .....	-	-	1	-	-----	-----	UIH,WIH1
16	87533-ZC0-630	MARK, AIR CLEANER .....	1	-	-	-	-----	-----	VMT
17	87539-898-620	MARK, EX. CAUTION (ENGLISH/FRENCH)	1	-	-	-	-----	-----	VMT
18	87565-ZB4-A00	PLATE, FUEL INDICATION .....	1	-	-	-	-----	-----	VMT
19	87522-ZH8-W40	MARK, CAUTION .....	1	-	-	-	-----	-----	HHQ4,HX4,KRA4,KRF4,KRS4,KRT4,LAJ4,LEH4,LHQ4,LSJ4,LX4,QHQ4,QMA4,QMA8,QME4,QWA4,QX4,QX7,RD4,RHQ4,RX4,SAJ4,SD4,SG24,SHQ4,SMA7,SM14,SSX4,SWX4,SXS4,SX4,SX7,TX4,VEX7,VMS4,VX4,VX7,WKT4,WMA3,WME4
			1	-	-	-	2476408	-----	QE,QEH,QLL,QPU,SE,VEX
			1	-	-	-	2923169	-----	DKR
20	87532-ZH8-W40	MARK, THROTTLE INDICATION ...	1	-	-	-	-----	-----	QWA4,QX7,SG24,SX7,VX7
			1	-	-	-	3939867	-----	SWX4
21	87135-ZE2-000	LABEL, E-SPEC (HONDA) (EPA STANDARD)	1	-	-	-	-----	-----	KRF4,SM14,VEK
			1	-	-	-	4077819	-----	KRT
	87135-ZE2-010	LABEL, E-SPEC (EPA STANDARD)	1	-	-	-	-----	-----	QX7,SX7,VEX7,VX7
	87135-ZE2-020	LABEL, E-SPEC (15.5X27.5) ...	1	-	-	-	-----	-----	LTS
22	87522-ZH7-V90	LABEL, FUEL WARNING .....	1	-	-	-	-----	-----	LTA
23	87526-ZH8-000	MARK B, COMBINATION .....	1	(1)	-	-	2612209	-----	DS,H1,LTA,LTJ,QSJ,R1,SCJ,SJ,SJC,SKJ,SMJ,STS,VET,WJ,WJP
			1	-	-	-	-----	-----	KRT,KRT6,LJC,LJS,LJT,LSJ,LTK1,LTR,LTS,QJW1,SJC1,SJC5,SM11,VEE1
			1	-	-	-	-----	-----	WDJ,WJP1,WJ1
			1	-	-	-	2613594	-----	LJ,SAJ
			1	-	-	-	2613699	-----	SSK3,STP

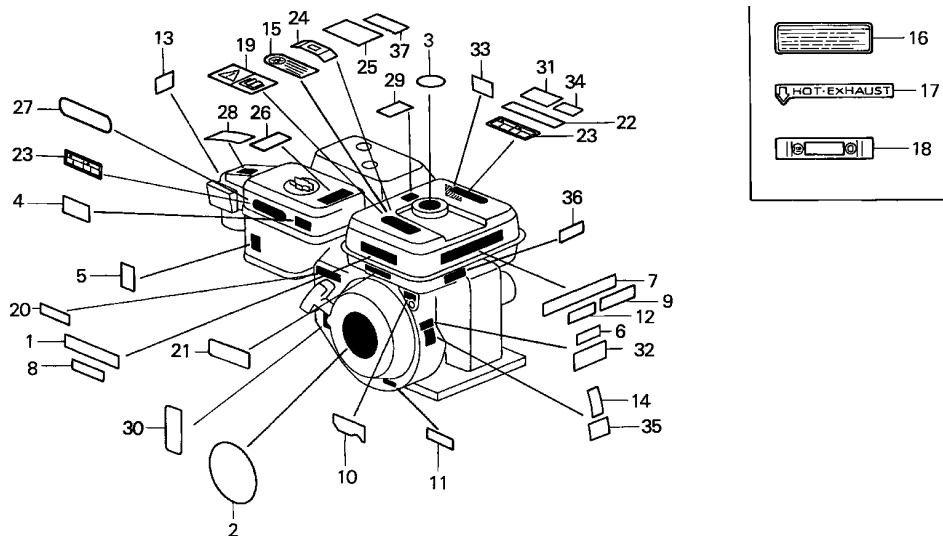

ZH70-E2800C



Ref. No.	Part No.	Description	Reqd. QTY				Serial No.	Parts catalogue code
			(1)	(2)	(3)	(4)		
24	87565-ZE2-000	MARK, FUEL (INTERNAL) .....	1	-	-	-	----- SKR,SMJ	
	87565-ZE2-A01	.....	1	-	-	-	----- VEK	
25	87593-737-A00	MARK, USE FUEL .....	1	-	-	-	2336518 LTA	
	87593-VB2-000	.....	1	-	-	-	2336519 2613638 LTA	
26	87106-737-J00	MARK, FUEL WARNING .....	1	-	-	-	----- WJ1	
27	87535-ZE1-840	MARK, AIR CLEANER SALES POINT .....	1	-	-	-	4170554 QXC,QXC9	
	87535-ZE1-841	.....	1	-	-	4170555	----- QXC,QXC9	
28	87534-ZE1-841	LABEL, AIR CLEANER CAUTION ..	1	-	-	-	----- QXC9	
29	87586-ZH7-W00	LABEL, FUEL CAUTION .....	1	-	-	-	2520549 QAA2	
			1	-	-	-	2292416 HXQ,HX2,LX2,QA2,QH2,QXG2,QXQ,QXS2,QX2,TX2	
30	87135-ZE2-000	LABEL, E-SPEC (HONDA) .....	1	-	-	-	----- DS,HX,H1,KR,KRT6,LD,LJ,LJC,LJS,LSJ,LTJ,LTK1,LTR,LX,PH,PX,QD,QX	
		(EPA STANDARD)	1	1	-	-	----- Q1,RD,RX,R1,SAJ,SCJ,SD,SJ,SJC,SJC1,SJC5,SKJ,SKR,SMJ,SM11,SSK3	
			1	-	-	-	4077819	----- STP,STS,SX,S1,TH,TX,UH,UX,VEE1,VET,VX,WJ,WJP,WJP1
	87135-ZE2-010	LABEL, E-SPEC (EPA STANDARD)	1	-	-	-	----- KRT	
			1	-	-	-	----- QX7,SX7,VEX7,VX7	
31	87106-737-J00	MARK, FUEL WARNING .....	1	-	-	-	----- VEK	
32	87152-ZH7-C30	LABEL, SPEC .....	1	-	-	-	4072259 VEK	
	87152-ZH7-C31	.....	1	-	-	-	4072260 VEK	
33	87539-737-J00	MARK, HEAT CAUTION .....	1	-	-	-	----- VEK	
34	87593-737-J00	MARK, USE FUEL .....	1	-	-	-	----- VEK	
35	87594-ZH7-B20	MARK, OIL CAUTION .....	1	-	-	-	----- VEK	
36	87532-ZH8-810	MARK, OIL ALERT (EXTERNAL) ..	1	-	-	-	----- VSX1	
			1	-	-	-	2186370	----- VSX
37	87532-ZH8-810	MARK, OIL ALERT (EXTERNAL) ..	1	-	-	-	----- WME2	



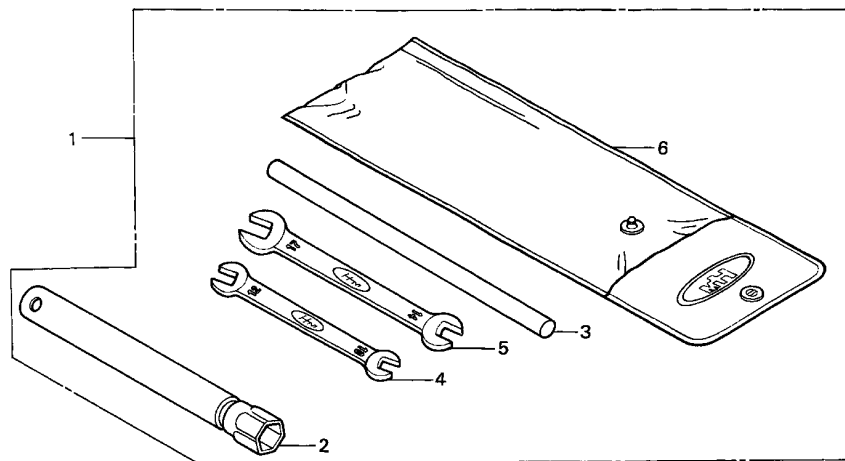

ZH70-E2900

Ref. No.	L.O.N.	(Relative ref. Number) Description	F.R.T.
----------	--------	---------------------------------------	--------

NO INFORMATION .....

Ref. No.	Part No.	Description	Reqd. QTY				Serial No.	Parts catalogue code
			(1)	(2)	(3)	(4)		
1	89000-ZE1-000	TOOL KIT .....	-	(1)	-	-		
2	89218-ZE1-000	WRENCH COMP., SPARK PLUG .....	-	(1)	-	-		
3	89219-805-000	HANDLE, BOX WRENCH .....	-	(1)	-	-		
4	99001-10120	SPANNER, 10X12 .....	-	(1)	-	-		
5	99001-14170	SPANNER, 14X17 .....	-	(1)	-	-		
6	99008-02300	BAG, TOOL, 230MM .....	-	(1)	-	-		

E-29-1

TOOL(2)

N 1

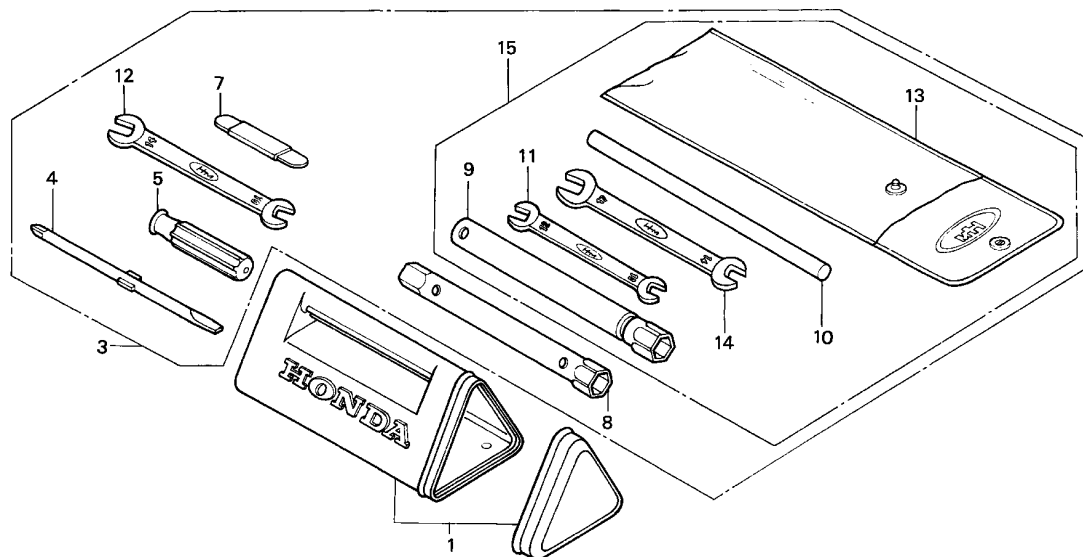

ZH70-E2901

Ref. L.O.N. (Relative ref. Number) F.R.T.  
No. Description

NO INFORMATION .....

Ref. No.	Part No.	Description	Reqd. QTY				Serial No.	Parts catalogue code
			(1)	(2)	(3)	(4)		
1	83501-ZF1-000	BOX, TOOL .....	1	-	1	-	LDB3,LW2,PM,PM2,QM,QT,SDB3,SN,SW2,UIH	
3	89000-ZH7-T00	TOOL KIT .....	-	-	1	-	UIH	
	89001-ZF1-000	BAG SET, TOOL .....	1	-	-	-	LDB3,LW2,PM2,QT,SDB3,SN,SW2	
			1	-	-	3070123	PM,QM	
4	89102-538-000	SHAFT, SCREW DRIVER .....	1	-	-	-	LDB3,LW2,PM2,QT,SDB3,SN,SW2	
			1	-	-	3070123	PM,QM	
5	89103-538-000	GRIP .....	1	-	-	-	LDB3,LW2,PM2,QT,SDB3,SN,SW2	
			1	-	-	3070123	PM,QM	
7	89210-ZF1-000	GAUGE ASSY., THICKNESS .....	1	-	-	-	LDB3,LW2,PM2,QT,SDB3,SN,SW2	
			1	-	-	3070123	PM,QM	
8	89216-ZF1-000	WRENCH, BOX .....	1	-	-	-	LDB3,LW2,PM2,QT,SDB3,SN,SW2	
			1	-	-	3070123	PM,QM	
	89216-ZH8-S00	WRENCH, PLUG .....	-	-	1	-		
9	89218-ZE1-000	WRENCH COMP., SPARK PLUG .....	1	-	1	-	2329687 QA,UIH	
			1	-	-	-	AR,DKR,DS,EN,ET,ETX,KR,KRA4,KRF4,KRS4,KRT,KRT4,KRT6,LAJ4,LDB3,LJ,LJC,LJS,LJT,LSJ,LSJ4,LTA,LTJ,LTK1,LTR,LTS,LW2,PM,PM2,QA2,QBU2,QJW1,QM,QMA8,QMX2,QSJ,QT,QTC2,QWA4,QXC,QXC9,RHC,SAD2,SAJ,SAJ4,SCJ,SDB3,SJ,SJC,SJC1,SJC5,SKJ,SKR,SMA7,SMJ,SMW2,SM11,SM12,SM14,SN,SSK1,SSK2,SSK3,SSX2,SSX4,STP,STS,SW2,VED,VED1,VED6,VEE1,VEK,VET,VS,VSX,VSX1,VS1,WDA6,WDJ,WD12,WJ,WJP,WJP1,WJ1,WKD6,WKT2,WKT4,WKT6,WMA3,WME2,WME4,WM1	
			1	-	-	-	KRS4	
	99004-21001	WRENCH, BOX (P21) .....	(1)	-	-	2329688	QA	
10	89219-805-000	HANDLE, BOX WRENCH .....	1	-	-	-	VMT	
			1	-	-	-	LDB3,LW2,PM,PM2,QM,QT,SDB3,SN,SW2,VEK	
			-	-	1	-		
11	99001-10120	SPANNER, 10X12 .....	1	-	-	-	LDB3,LW2,PM,PM2,QM,QT,SDB3,SN,SW2	

2

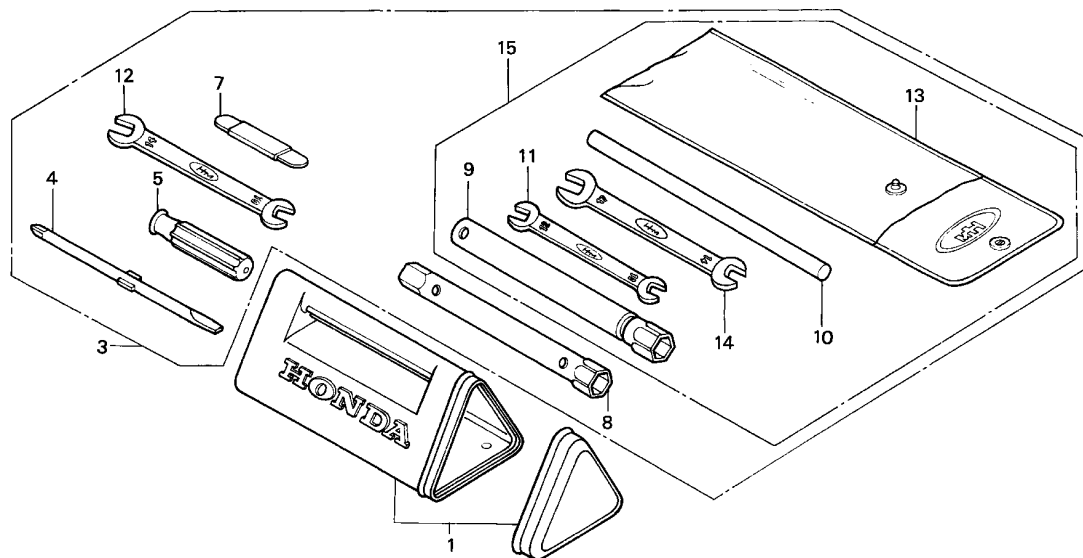

ZH70-E2901



Ref. No.	Part No.	Description	Reqd. QTY				Serial No.	Parts catalogue code
			(1)	(2)	(3)	(4)		
12	99001-10140	SPANNER, 10X14 .....	1	-	-	-	----- LDB3,LW2,PM2,QT,SDB3,SN,SW2	
13	99008-02300	BAG, TOOL, 230MM .....	1	-	-	----- 3070123	PM,QM	
14	99001-14170	SPANNER, 14X17 .....	1	-	-	----- 3070124	PM,QM	
15	89000-ZE1-000	TOOL KIT .....	1	-	-	----- 3070124	PM,QM	

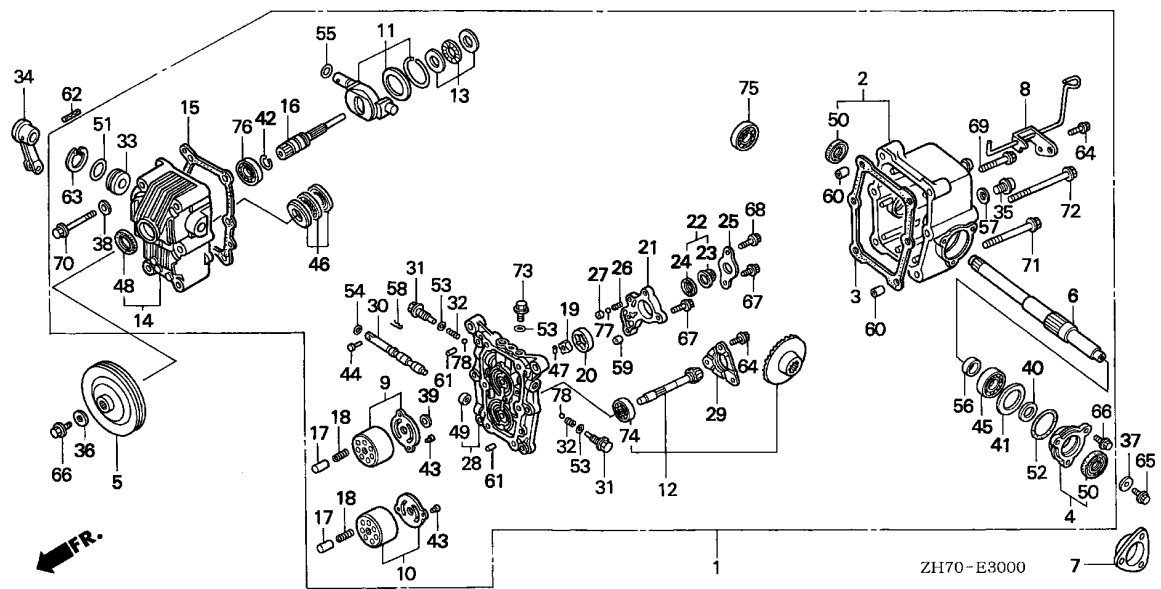

Ref. No.	L.O.N.	(Relative ref. Number) Description	F.R.T.
----------	--------	------------------------------------	--------

NO INFORMATION .....

Ref. No.	Part No.	Description	Reqd. QTY				Serial No.	Parts catalogue code
			(1)	(2)	(3)	(4)		
1	20001-VD6-R00	TRANSMISSION ASSY. ....	1	-	-	-	SSK3	
2	21210-VD6-854	CASE COMP., RR. TRANSMISSION	1	-	-	-	SSK3	
3	21215-VD6-851	PACKING, RR. TRANSMISSION CASE	1	-	-	-	SSK3	
4	21225-VD6-853	HOLDER COMP., OIL SEAL .....	1	-	-	-	SSK3	
5	22423-767-000	PULLEY, WHEEL DRIVEN (133MM)	1	-	-	-	SSK3	
6	23236-VD6-871	SHAFT, CROSS .....	1	-	-	-	SSK3	
7	23384-767-000	HOLDER, BEARING .....	1	-	-	-	SSK3	
8	24176-VD6-852	ARM COMP., NEUTRAL VALVE ....	1	-	-	-	SSK3	
9	25010-VD6-851	PLATE SET, PUMP CYLINDER ....	1	-	-	-	SSK3	
10	25011-VD6-851	PLATE SET, MOTOR CYLINDER ...	1	-	-	-	SSK3	
11	25012-VD6-850	BOWL SET, CONTROL .....	1	-	-	-	SSK3	
12	25013-VD6-850	GEAR SET, MOTOR SHAFT & BEVEL	1	-	-	-	SSK3	
13	25014-VD6-850	BEARING SET, THRUST NEEDLE ..	1	-	-	-	SSK3	
14	25310-VD6-M50	CASE COMP., PUMP (VVR30) .....	1	-	-	-	SSK3	
15	25312-VD6-851	PACKING, PUMP CASE .....	1	-	-	-	SSK3	
16	25321-VD6-852	SHAFT, PUMP .....	1	-	-	-	SSK3	
17	25342-773-003	PISTON, PUMP .....	14	-	-	-	SSK3	
18	25343-773-000	SPRING, PISTON .....	14	-	-	-	SSK3	
19	25411-VD6-852	ROTOR, TROCHOID .....	1	-	-	-	SSK3	
20	25415-VD6-851	VANE, TROCHOID .....	1	-	-	-	SSK3	
21	25416-VD6-853	HOUSING, TROCHOID .....	1	-	-	-	SSK3	
22	25420-VD6-852	FILTER ASSY., SUCTION .....	1	-	-	-	SSK3	
23	25421-VD6-852	FILTER, SUCTION .....	1	-	-	-	SSK3	
24	25422-VD6-851	SEAL, RUBBER .....	1	-	-	-	SSK3	
25	25425-VD6-852	PLATE, FILTER CAP .....	1	-	-	-	SSK3	



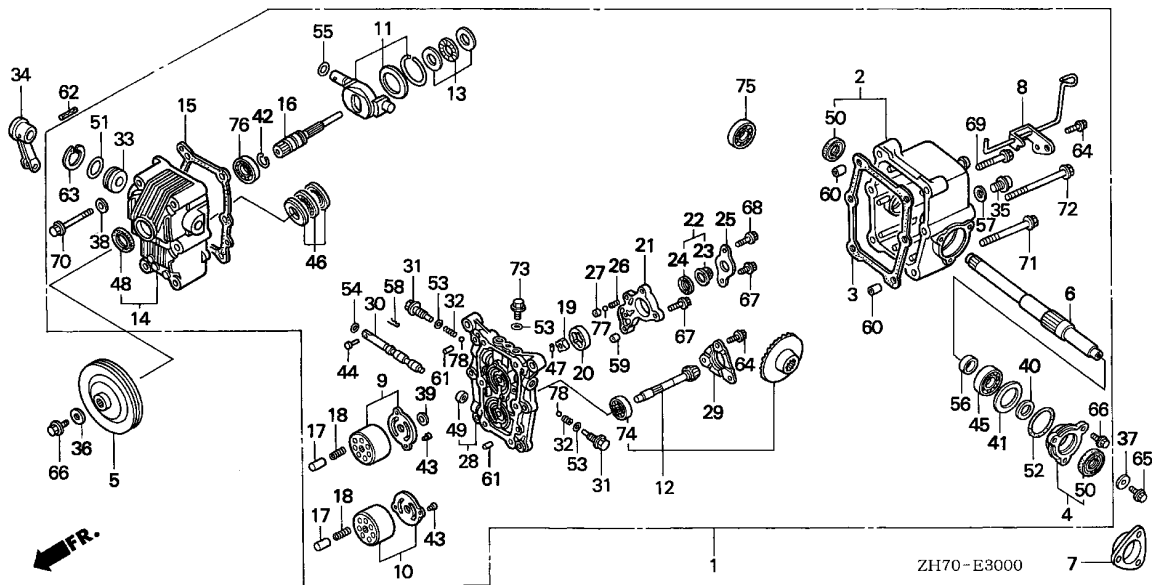

Ref. No.	Part No.	Description	Reqd. QTY				Serial No.	Parts catalogue code
			(1)	(2)	(3)	(4)		
26	25431-VD6-851	SPRING, RELIEF VALVE	1	-	-	-	SSK3	
27	25437-VD6-852	SEAT, RELIEF VALVE	1	-	-	-	SSK3	
28	25510-VD6-854	PLATE COMP., DISTRIBUTOR	1	-	-	-	SSK3	
29	25518-VD6-850	HOLDER, BEARING	1	-	-	-	SSK3	
30	25521-VD6-850	SPOOL, NEUTRAL VALVE	1	-	-	-	SSK3	
31	25525-773-000	BOLT, CHECK VALVE	2	-	-	-	SSK3	
32	25526-VD6-851	SPRING, CHECK VALVE	2	-	-	-	SSK3	
33	25813-773-000	BUSH, CONTROL BOWL (B)	1	-	-	-	SSK3	
34	40311-767-000	ARM, CLUTCH	1	-	-	-	SSK3	
35	90081-MC7-000	BOLT, PLUG, 14MM	1	-	-	-	SSK3	
36	90417-115-000	WASHER, CAMSHAFT SIDE	1	-	-	-	SSK3	
37	90474-704-000	WASHER, 6X17	1	-	-	-	SSK3	
38	90503-VD6-850	WASHER, SEALING, 9X16X1.5	6	-	-	-	SSK3	
39	90504-VD6-851	WASHER, THRUST, 8MM	1	-	-	-	SSK3	
40	90508-VD6-850	WASHER, PLAIN, 15MM	1	-	-	-	SSK3	
41	90565-VD6-852	SHIM A, BEVEL GEAR (1.5MM)	1	-	-	-	SSK3	
	90566-VD6-852	SHIM B, BEVEL GEAR (1.55MM)	1	-	-	-	SSK3	
	90567-VD6-852	SHIM C, BEVEL GEAR (1.6MM)	1	-	-	-	SSK3	
	90568-VD6-852	SHIM D, BEVEL GEAR (1.65MM)	1	-	-	-	SSK3	
	90569-VD6-851	SHIM E, BEVEL GEAR (1.7MM)	1	-	-	-	SSK3	
	90570-VD6-852	SHIM F, BEVEL GEAR (1.75MM)	1	-	-	-	SSK3	
42	90663-VD6-850	CLIP, BEARING	1	-	-	-	SSK3	
43	90755-VD6-900	DOWEL PIN, 3X5.8	4	-	-	-	SSK3	
44	90759-VD6-850	PIN, NEUTRAL VALVE	1	-	-	-	SSK3	
45	91007-MN5-003	BEARING, RADIAL BALL, 6904	1	-	-	-	SSK3	
	(NTN)		1	-	-	-	SSK3	

2

Ref. No.	Part No.	Description	Reqd. QTY				Serial No.	Parts catalogue code
			(1)	GX120K1 (2)	(3)	(4)		
46	91069-VD6-851	BEARING, THRUST BALL, 51204 ..	1	-	-	-	SSK3	
47	91151-VD6-851	ROLLER, 2.5X11.8 .....	1	-	-	-	SSK3	
48	91202-722-003	OIL SEAL, 17X30X6 .....	1	-	-	-	SSK3	
49	91255-VD6-851	DUST SEAL, 9X15X5 .....	1	-	-	-	SSK3	
50	91272-733-931	OIL SEAL, 15X28X7 .....	2	-	-	-	SSK3	
51	91304-GB1-900	O-RING, 25X2.4 .....	1	-	-	-	SSK3	
52	91352-VD6-851	O-RING, 34.6X1.9 .....	1	-	-	-	SSK3	
53	91355-VD6-852	O-RING, 11X1.9 .....	4	-	-	-	SSK3	
54	91360-VD6-851	O-RING, 5.8X1.9 .....	1	-	-	-	SSK3	
55	91361-VD6-901	O-RING, 11.8X1.9 .....	1	-	-	-	SSK3	
56	91589-VD6-851	COLLAR, BEVEL GEAR .....	1	-	-	-	SSK3	
57	94109-14000	WASHER, DRAIN PLUG, 14MM .....	1	-	-	-	SSK3	
58	94251-04000	PIN, LOCK, 4MM .....	1	-	-	-	SSK3	
59	94301-08100	DOWEL PIN, 8X10 .....	2	-	-	-	SSK3	
60	94301-10120	DOWEL PIN, 10X12 .....	2	-	-	-	SSK3	
61	94302-05080	PIN B, DOWEL, 5X8 .....	2	-	-	-	SSK3	
62	94305-40282	PIN, SPRING, 4X28 .....	1	-	-	-	SSK3	
63	94520-30000	CIRCLIP, INTERNAL, 30MM .....	1	-	-	-	SSK3	
64	95701-06012-08	BOLT, FLANGE, 6X12 .....	4	-	-	-	SSK3	
65	95701-06016-00	BOLT, FLANGE, 6X16 .....	1	-	-	-	SSK3	
66	95701-06016-08	BOLT, FLANGE, 6X16 .....	4	-	-	-	SSK3	
67	95701-06025-08	BOLT, FLANGE, 6X25 .....	2	-	-	-	SSK3	
68	95701-06032-00	BOLT, FLANGE, 6X32 .....	1	-	-	-	SSK3	
69	95701-08045-08	BOLT, FLANGE, 8X45 .....	2	-	-	-	SSK3	
70	95701-08065-00	BOLT, FLANGE, 8X65 .....	6	-	-	-	SSK3	
71	95701-08070-08	BOLT, FLANGE, 8X70 .....	2	-	-	-	SSK3	
72	95701-08090-08	BOLT, FLANGE, 8X90 .....	2	-	-	-	SSK3	
73	95701-10016-00	BOLT, FLANGE, 10X16 .....	2	-	-	-	SSK3	
74	96100-60010-00	BEARING, RADIAL BALL, 6001 ..	1	-	-	-	SSK3	
75	96100-60020-00	BEARING, RADIAL BALL, 6002 ..	1	-	-	-	SSK3	
76	96100-60030-00	BEARING, RADIAL BALL, 6003 ..	1	-	-	-	SSK3	
77	96211-06000	BALL, STEEL, #6 (3/16) .....	1	-	-	-	SSK3	
78	96211-08000	BALL, STEEL, #8 (1/4) .....	2	-	-	-	SSK3	

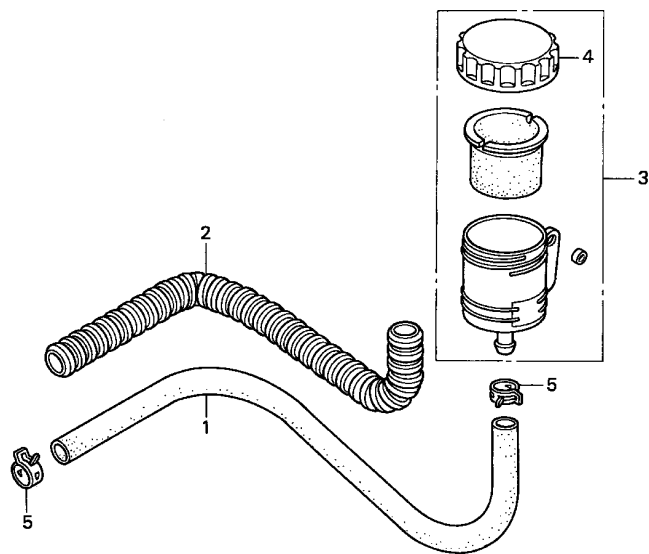

Ref. L.O.N. (Relative ref. Number) F.R.T.  
No. Description

NO INFORMATION .....

Ref. No.	Part No.	Description	Reqd. QTY				Serial No.	Parts catalogue code
			(1)	(2)	(3)	(4)		
1	15422-767-000	TUBE, OIL .....	1	-	-	-	SSK3	
2	15428-767-000	PROTECTOR, OIL TUBE .....	1	-	-	-	SSK3	
3	56850-767-000	TANK ASSY., OIL .....	1	-	-	-	SSK3	
4	56862-767-300	BODY, OIL CAP .....	1	-	-	-	SSK3	
5	91462-SA5-950	CLAMP D, 19MM .....	2	-	-	-	SSK3	

2

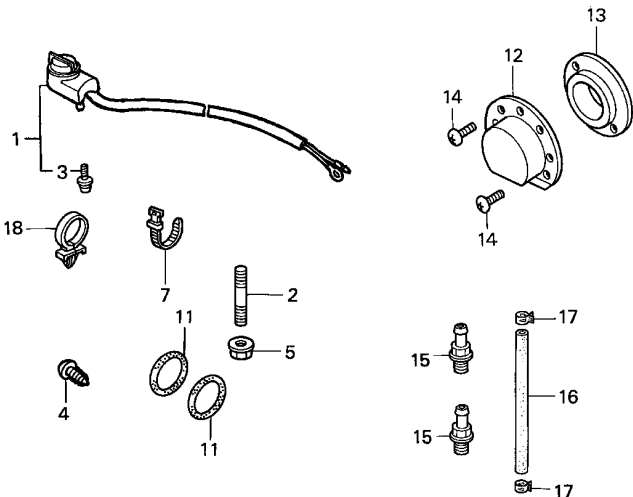

ZH70-E4000B

Ref. L.O.N. (Relative ref. Number) F.R.T.  
No. Description

NO INFORMATION .....

Ref. No.	Part No.	Description	Reqd. QTY				Serial No.	Parts catalogue code
			(1)	(2)	(3)	(4)		
1	35120-746-C21	SWITCH ASSY., ENGINE STOP ...	1	-	-	-	----- LEH4,QPU	
2	90001-ZK7-V00	BOLT, STUD, 10X32 .....	3	-	-	2352578	----- QEH	
	90002-ZK7-V00	BOLT, STUD, 10X60 .....	1	-	-	-----	AR,DKR,KRA4,KRF4,KRS4	
3	90101-733-921	BOLT, 3X12(SEMS) .....	1	-	-	-----	LEH4,QPU	
			1	-	-	2352578	----- QEH	
4	93901-32120	SCREW, TAPPING, 3X8 .....	1	-	-	-----	LEH4	
5	94050-10000	NUT, FLANGE, 10MM .....	4	-	-	-----	AR,DKR,KRA4,KRF4,KRS4	
7	95014-62100	BAND B1, WIRE .....	1	-	-	-----	LEH4,QPU	
			1	-	-	2352578	----- QEH	
11	78118-YB0-003	RING, SEAL (B) .....	2	-	-	-----	WJP,WJP1,WME4	
12	18340-ZE1-010	DEFLECTOR COMP. ....	1	-	-	-----	SWX2,SWX4	
	18340-ZH7-U20	.....	1	-	-	-----	LTS	
13	18522-ZE1-000	GUIDE, MUFFLER .....	1	-	-	-----	SWX2,SWX4	
14	90002-ZG0-003	SCREW, TAPPING, 4X8 .....	2	-	-	-----	SWX2,SWX4	
	90055-ZE1-000	SCREW, TAPPING, 4X6 .....	2	-	-	-----	LTS	
15	15550-ZK8-P90	JOINT, DRAIN .....	2	-	-	-----	SM11,SM12,SM14	
16	15552-ZB9-000	TUBE, DRAIN .....	1	-	-	-----	SM11,SM12,SM14	
17	95002-41200-08	CLAMP, TUBE (D12) .....	2	-	-	-----	SM11,SM12,SM14	
18	90617-SA0-003	CLIP, WIRE HARNESS .....	1	-	-	4091238	----- KRS4	





E-40-1

FUEL TANK(OTHER PARTS)

N 8

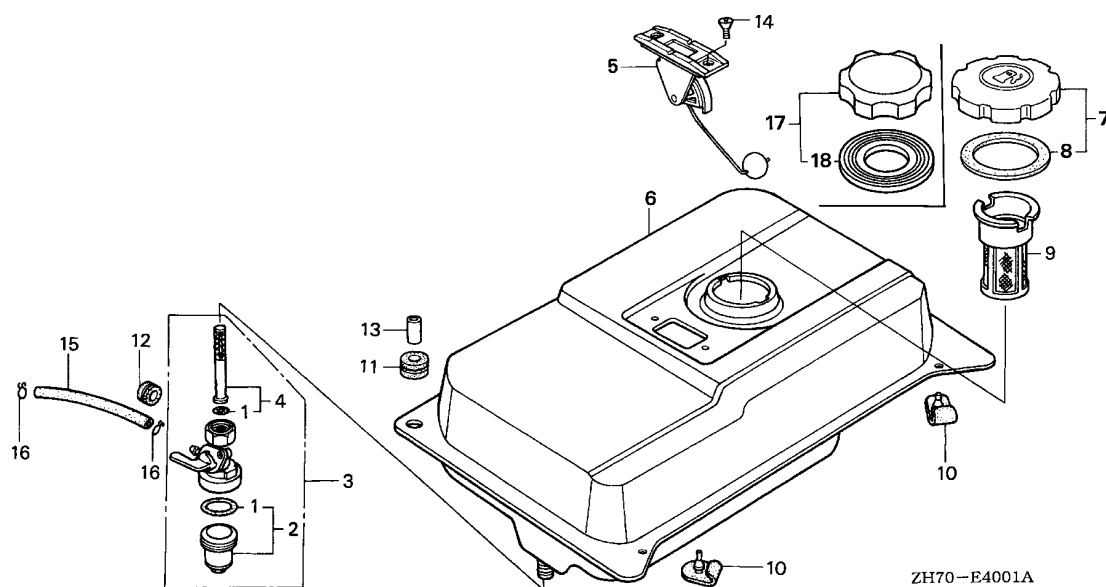

Ref. No.	L.O.N.	(Relative ref. Number) Description	F.R.T.
1	3101C4	PACKING SET, COCK .....	0.2
3	3101A3	COCK, FUEL .....	0.2
4	3101D5	SCREEN, FUEL STRAINER .....	0.2
5	6171A1	METER UNIT, FUEL .....	0.1
6	3101H7	TANK, FUEL .....	0.2
9	3101A6	FILTER, FUEL .....	0.1
15	3101F2	TUBE, FUEL COCK .....	0.2

2

Ref. No.	Part No.	Description	Reqd. QTY				Serial No.	Parts catalogue code
			(1)	(2)	(3)	(4)		
1	16080-898-631	PACKING SET, COCK .....	1	-	-	-	VMT	
2	16081-471-831	CUP, FUEL STRAINER .....	1	-	-	-	VMT	
3	16950-898-632	COCK ASSY., FUEL .....	1	-	-	4112838	VMT	
	16950-898-633	.....	1	-	-	4112839	VMT	
4	16952-883-005	SCREEN SET .....	1	-	-	4112838	VMT	
	16952-GG2-731	.....	1	-	-	4112839	VMT	
5	17505-ZB2-003	METER ASSY., FUEL .....	1	-	-	-	VMT	
6	17510-ZB2-000ZB	TANK COMP., FUEL *R8*.....BRIGHT RED	1	-	-	3678788	VMT	
7	17620-ZH7-023	CAP COMP., FUEL FILLER (BLACK)	1	-	-	4203082	VMT	
8	17631-ZH7-003	PACKING, FUEL FILLER CAP (39X58X3)	1	-	-	4203082	VMT	
9	17672-ZE2-W01	FILTER, FUEL .....	1	-	-	-	VMT	
10	50319-ZB2-000	RUBBER, TANK MOUNTING .....	2	-	-	-	VMT	
11	90852-898-000	RUBBER, CONTROL BOX .....	2	-	-	-	VMT	
12	90854-ZB3-000	RUBBER, FUEL (9X15X20) .....	1	-	-	-	VMT	
13	91552-898-000	COLLAR, CONTROL BOX .....	2	-	-	-	VMT	
14	93600-05010-0A	SCREW, FLAT, 5X10 .....	2	-	-	-	VMT	
15	95001-45250-40	TUBE, FUEL, 4.5X250 (95001-45001-60M)	1	-	-	-	VMT	
16	95002-02080	CLIP, TUBE (B8) .....	2	-	-	-	VMT	
17	17620-Z0T-814	CAP COMP., FUEL FILLER (CHROME PLATED)	1	-	-	4203083	VMT	
18	17631-Z0T-812	PACKING, FUEL FILLER CAP (39X62X3)	1	-	-	4203083	VMT	

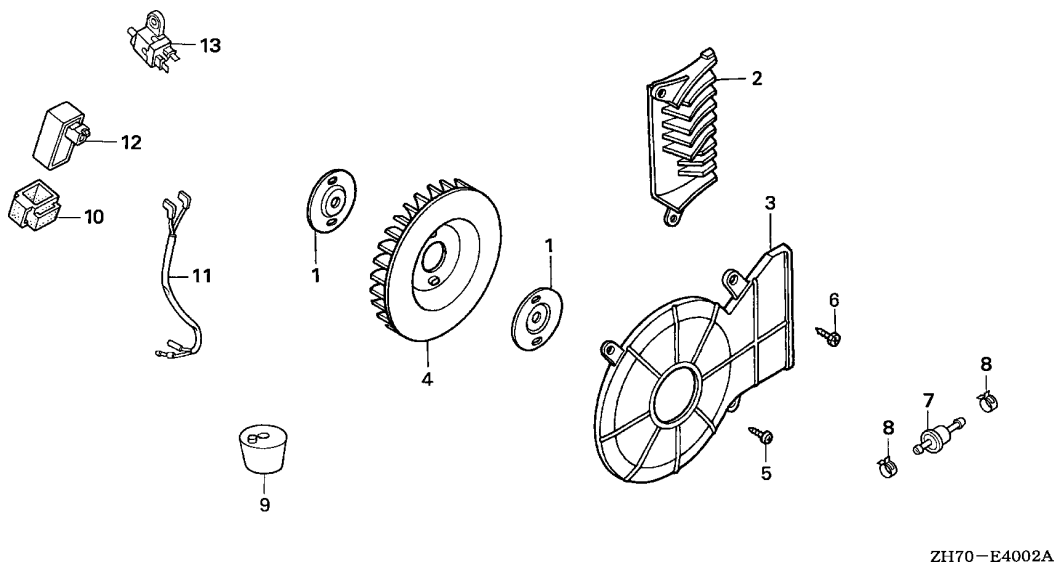

ZH70-E4002A

Ref. No.	L.O.N.	(Relative ref. Number) Description	F.R.T.
2	8101R3	GUIDE, GENERATOR AIR .....	0.1
3	6201C5	COVER, GENERATOR COOLING FAN .	0.1
4	1141G7	FAN, ENGINE COOLING .....	0.2
7	3101H8	STRAINER, FUEL .....	0.1
11	6151F9	CORD, CLUTCH SWITCH .....	0.1
12	6211A7	CONTROL UNIT, ENGINE .....	0.1
13	6151B4	SWITCH, CLUTCH .....	0.1

Ref. No.	Part No.	Description	Reqd. QTY				Serial No.	Parts catalogue code
			(1)	GX120K1 (2)	(3)	(4)		
1	19512-ZA8-000	PLATE, FAN SETTING .....	2	-	-	-	VEE1	
2	31107-ZC0-003	GUIDE, GENERATOR AIR .....	1	-	-	-	VEE1	
3	31109-ZC0-003	COVER, GENERATOR FAN .....	1	-	-	-	VEE1	
4	31112-ZC0-003	FAN, COOLING .....	1	-	-	-	VEE1	
5	90031-ZA1-003	SCREW, TAPPING, 5X14 .....	1	-	-	-	VEE1	
6	90031-ZC0-003	SCREW, TAPPING, 5X18 .....	2	-	-	-	VEE1	
7	16910-GB2-005	STRAINER COMP., FUEL .....	1	-	-	-	KRF4,KRT,KRT6	
8	95002-40850-08	CLAMP, TUBE (D8.5) .....	2	-	-	-	KRF4,KRT,KRT6	
9	60407-812-000	RUBBER, BOTTOM .....	4	-	-	-	AR,KR	
10	30401-GA7-000	CUSHION, C.D.I. UNIT .....	1	-	-	-	3176152	
11	32153-735-J10	CORD, CLUTCH SWITCH .....	1	-	-	-	AR,KR	
12	34100-735-J10	CONTROL UNIT, ENGINE .....	1	-	-	-	3176152	
13	35420-735-921	SWITCH ASSY., CLUTCH .....	1	-	-	-	AR,KR	
							LJC	
							SKR	
							SKR	
							SKR	



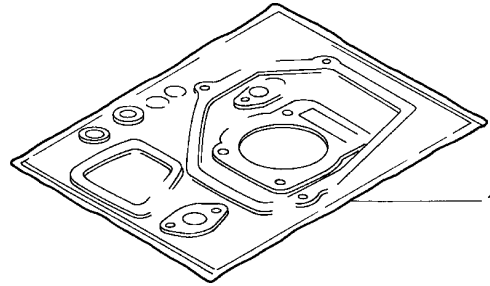

HENG-X0003

Ref. L.O.N. (Relative ref. Number) F.R.T.  
No. Description

NO INFORMATION .....

Ref. No.	Part No.	Description	Reqd. QTY				Serial No.	Parts catalogue code
			(1)	(2)	(3)	(4)		
1	061A1-ZH7-010	GASKET KIT .....	1	1	-	-	-----	DS, HXQ, HX2, H1, KRT, LD, LJ, LTA, LTK1, LTR, LX, LX2, PH, PX, QAA2, QA2, QD, QH2, QSJ, QXG2, QXQ, QXS2, QX2, Q1, RD, RX, R1, SCJ, SD, SJ, SKJ, SMJ, SSK1, STP, STS, SX, TH, TX2, UH, UX, U1, VET, VH, VX, V1, WJ, WJP1, W1
	061A1-ZH7-020	.....	1	-	-	-	-----	2541695 QA, QXC, QXG, QXS
	061A1-ZH7-700	.....	1	-	-	-	-----	2541696 HTF2, KRT4, LDB1, LDB3, LJD2, PX2, QJG2, QJW1, QMA4, QMA8, QMX2, QTC2, QWA4, QXC9, SAJ, SDB1, SDB3, SG24, SJC, SMA7, SMW2, SSK2, SSK3, VAX4, VEE1, VPR4, WD12, WKT2, WMA3, WME2
	061A1-ZH7-710	.....	1	-	-	-	-----	QA, QXC, QXG, QXS
	061A1-ZH7-720	.....	-	1	-	-	-----	EN, ET, ETX
	061A1-ZH7-730	.....	1	-	-	-	-----	LD, LE, QD, QE, RD, SD, SE
	061A1-ZH7-740	.....	1	-	-	-	-----	LW2, PM, PM2, QM, QT, SN, SW2
	061A1-ZH7-800	.....	1	-	-	-	-----	HHQ4, HX4, LD4, LHQ4, LSJ4, LX4, QA, QHQ4, QLL, QPU, QX4, RD4, RHQ4, RX4, SD4, SHQ4, SX4, TX4, VX4, WME4
	061A1-ZH7-811	.....	1	-	-	-	-----	LTJ, WJP
	06111-ZK7-U30	.....	1	-	-	-	-----	LJC, LJT, LSJ, SJC5, WDJ, WJ1
	06111-ZK7-V00	.....	1	-	-	-	-----	AR
							-----	KR, KRA4, KRF4



# PART NO. INDEX

**2-B 2**

Part Number	Address	Page	Ref.	Part Number	Address	Page	Ref.	Part Number	Address	Page	Ref.	Part Number	Address	Page	Ref.			
16263-883-W10	L15	165	38	16578-ZE1-000	L9	159	13	16956-ZE1-811	H9	95	25	17404-841-000	J4	122	7			
16269-ZE1-800	J9	127	1	16580-ZH7-000	L9	159	14	15	107	26	17410-ZE0-030	I14	116	9	K14	148	5	
16271-ZE1-000	I11	113	1	16580-ZH7-810	L10	160	15	16957-ZE1-812	H9	95	26	N8	190	18	17631-ZH7-003	K7	141	16
	J4	122	1	16580-ZH7-850	L9	159	15	15	107	27	J3	121	6	N8	190	8		
	J6	124	1	16580-ZH7-R00	L9	159	15	16958-397-771	K12	146	5	J4	122	8	17670-899-000	K12	146	12
16500-ZH7-000	L5	155	1	16580-ZH7-U40	L10	160	15	16959-471-831	K12	146	6	J6	124	10	17670-ZH7-A81	K7	141	17
16500-ZH7-810	L5	155	2	16582-883-300	H8	94	17	16967-GA6-671	K12	146	7	I14	116	9	17672-880-000	K7	141	18
16500-ZH7-820	L6	156	3		I3	105	18	16967-ZE0-811	15	107	28	J8	126	12	17672-887-791	K7	141	18
16500-ZH7-830	L6	156	4	16584-883-300	L10	160	16					J3	121	7	17672-ZE2-W00	K7	141	17
16500-ZH7-850	L5	155	2		L16	166	6	17000				J4	122	9	17672-ZE2-W01	K7	141	17
16500-ZH7-860	L5	155	1		M2	168	6					J6	124	11	K14	148	6	
16500-ZH7-U40	L6	156	3	16592-ZE1-810	L11	161	17	17200-ZK7-V01	J8	126	2	J6	124	11	N8	190	9	
16500-ZH7-U41	L6	156	3		M2	168	7	17205-PC6-000	K9	143	26	J6	124	12	17672-ZK7-800	K13	147	9
16500-ZH7-U42	L6	156	3	16594-883-010	L11	161	18	17210-ZE0-822	I11	113	2	J6	124	13	17673-893-000	K7	141	19
16500-ZK7-S40	L5	155	2	16598-ZE0-000	H8	94	18	17210-ZE1-822	J6	124	2	J6	124	14	17682-817-020	K7	141	20
16500-ZK7-U50	L5	155	2		I3	105	19	17210-ZK7-V01	J8	126	3	J7	125	15				
16500-ZK7-V60	L5	155	2	16598-ZE1-000	H8	94	18	17211-ZB2-000	J9	127	2	K10	144	39	18000			
16510-ZE1-000	E11	49	4		I3	105	19	17211-ZE1-000	J2	120	1	K12	146	8				
16511-ZE1-000	E11	49	5	16599-ZG1-M10	L11	161	19	17212-ZB2-000	J9	127	3	N8	190	5	18300-ZH8-840	J14	132	28
16512-ZE1-000	E11	49	6		L15	165	37	17212-ZE1-000	J2	120	2	K10	144	40	18310-ZB3-C00	K3	137	1
16513-ZE1-000	E11	49	7		L16	166	7	17216-PM4-300	J8	126	4	K10	144	40	18310-ZE0-A20	J15	133	31
16531-ZE1-000	E11	49	8	16610-ZB2-000	I3	105	20	17217-PM4-300	J8	126	5	K13	147	2	18310-ZE1-821	J16	134	2
16541-ZE1-000	E11	49	9	16610-ZE1-000	H8	94	19	17218-ZE0-821	I12	114	3	K13	147	3	18310-ZE1-900	J10	128	2
16550-ZH7-V30	L15	165	34		I3	105	20	17218-ZE1-821	I12	114	3	N8	190	6	18310-ZF1-000	J10	128	2
16550-ZK7-V00	L15	165	35	16610-ZE1-810	H8	94	20		J6	124	3	K12	146	9	18310-ZH7-V90	J10	128	2
16551-ZE0-010	L6	156	5		I3	105	21	17218-ZK7-V01	J8	126	6	K5	139	12	18310-ZH8-810	J10	128	2
	L16	166	1	16615-ZE1-010	H8	94	21	17219-733-010	J6	124	4	K5	139	12	18310-ZH8-T30	J10	128	2
	M2	168	1		I3	105	22	17220-ZB2-000	J9	127	4	K5	139	12	18310-ZK7-V01	K2	136	1
16551-ZK7-S30	L6	156	5	16617-890-010	H8	94	22	17230-ZE0-820	I12	114	4	K5	139	12	18310-ZK8-V50	J10	128	2
16552-896-650	L15	165	36		I3	105	23	17230-ZE1-820	I12	114	4	K5	139	12	18315-ZE1-000	J16	134	3
16555-ZE0-000	L7	157	6	16727-705-000	L11	161	20	17230-ZE1-841	J6	124	5	K5	139	12	18320-ZB2-000	K3	137	7
	L16	166	2	16729-705-010	L11	161	21	17230-ZE1-850	J6	124	6	K5	139	12	18320-ZE1-000	J11	129	3
	M2	168	2	16854-ZH8-000	H10	96	35	17230-ZK7-V01	J8	126	7	K5	139	12	18320-ZE1-T02	J11	129	3
16555-ZK7-S30	L15	165	39		K4	138	1	17231-ZB2-000	J9	127	5	K5	139	12	18320-ZF1-H00	J11	129	3
16561-733-010	M2	168	3		K12	146	2	17231-ZE0-000	J2	120	3	K5	139	12	18320-ZF1-H01	J11	129	3
16561-ZE0-020	L7	157	7		K13	147	1	17232-891-000	I13	115	5	K5	139	12	18320-ZF1-H50	J16	134	4
	L16	166	3		K14	148	1		J6	124	7	K5	139	12	18320-ZF1-H51	J16	134	4
16562-ZE0-020	L7	157	8	16854-ZH8-810	K4	138	4	17233-896-701	J10	128	1	K13	147	4	18320-ZH8-W01	J11	129	3
	L16	166	4	16910-GB2-005	K4	138	5		J16	134	1	K5	139	12	18321-ZH8-000	J11	129	3
	M2	168	4		N9	191	7	17235-ZE1-830	I13	115	6	K5	139	12	18321-ZH8-820	J16	134	4
16562-ZE1-020	L16	166	4	16910-ZG0-U01	K4	138	7	17235-ZE1-831	I13	115	6	K14	148	3	18325-ZB2-000	K3	137	8
16570-733-000	M2	168	5	16910-ZG0-U02	K4	138	7	17238-ZE0-010	I13	115	7	K13	147	5	18325-ZE1-010	J11	129	4
16570-ZB0-000	L16	166	5	16950-732-000	K4	138	6		J2	120	4	K5	139	14	18329-ZB2-000	K3	137	9
16570-ZE0-900	L5	155	2	16950-898-632	N8	190	3		J4	122	2	K12	146	10	18330-ZB2-000	K3	137	10
16570-ZE0-901	L5	155	2	16950-898-633	N8	190	3		J6	124	8	K11	145	43	18331-883-810	J16	134	5
16570-ZE0-902	L5	155	2	16950-ZB4-015	K12	146	3	17238-ZE7-010	I13	115	7	K14	148	4	18338-ZB3-E30	K3	137	11
16570-ZE0-S00	L5	155	2	16952-883-005	K4	138	8		J8	126	8	N8	190	17	18338-ZK7-V00	K2	136	2
16570-ZE0-S10	L5	155	2		N8	190	4	17239-733-000	J6	124	9	K5	139	14	18338-ZK7-V20	K2	136	3
16570-ZH7-W40	L5	155	2	16952-GG2-731	N8	190	4	17239-ZB2-000	J9	127	6	K13	147	6	18340-ZE0-A60	J15	133	32
16570-ZK7-U20	L5	155	2	16952-ZB4-005	K12	146	4	17239-ZE1-000	I13	115	8	K6	140	15	18340-ZE1-010	J11	129	5
16571-ZE0-S10	L8	158	9	16953-ZE1-812	H8	94	23		J3	121	5	K6	140	15	N7	189	12	
16571-ZH7-000	L7	157	9		I3	105	24		J4	122	3	N8	190	7	18340-ZH7-U20	J11	129	5
16571-ZH7-860	L7	157	9	16954-ZE1-811	H8	94	24		J8	126	9	K10	144	41	N7	189	12	
16571-ZH7-U40	L8	158	9		I4	106	25	17251-ZE0-S10	J8	126	10	K10	144	41	18355-898-630	K3	137	2
16571-ZH7-U41	L8	158	9	16954-ZE1-812	H8	94	24	17252-ZB2-000	J9	127	7	K13	147	7	18355-ZE1-000	J11	129	6
16571-ZH8-000	L8	158	9		I4	106	25	17255-758-000	J8	126	11	K13	147	8	18355-ZE1-810	J16	134	6
16574-ZE1-000	L8	158	10	16954-ZF0-841	I4	106	25	17401-ZE1-810	J4	122	4	K7	141	16	18381-ZE1-800	K3	137	3
16575-ZH8-000	L9	159	11	16955-ZE1-000	K5	139	9	17402-ZE1-810	J4	122	5	K12	146	11	18381-ZH8-000	J12	130	7
16576-891-000	L9	159	12		K14	148	2	17403-ZE1-810	J4	122	6	K11	145	44	18381-ZH8-800	J12	130	7

3





# PART NO. INDEX

Part Number	Address	Page	Ref.	Part Number	Address	Page	Ref.	Part Number	Address	Page	Ref.	Part Number	Address	Page	Ref.
92000				J7		125	23	K9		143	32	95701-10016-00	N5	187	73
				J8		126	13	K12		146	20	95723-08055-00	E6	44	14
92000-08025-0A	F4	58	13	K2		136	6	K13		147	13	95900-06012-00	K1	135	23
	M4	170	11	K3		137	12	K14		148	10	95900-06025-00	K10	144	35
92000-08035-0A	M7	173	24	K8		142	25	N8		190	16				
92101-08020-0A	K3	137	5	K13		147	11	95002-02100	K9	143	33	96000			
92101-08025-0A	F5	59	13	K14		148	8	95002-40800-08	H10	96	37				
	M4	170	11	L15		165	33		K10	144	37	96100-60010-00	N5	187	74
	M5	171	10	M1		167	13				38	96100-60020-00	N5	187	75
92101-08035-0A	M7	173	24	M2		168	11	95002-40850-08	K10	144	38	96100-60030-00	N5	187	76
92800-12000	M7	173	25	J9	94050-06080	127	9	N9		191	8	96100-60050-00	M5	171	14
				E13	94050-10000	51	19	95002-41200-08	N7	189	17	96100-62040-00	M8	174	12
				N7		189	5	95002-50000	K9	143	34	96100-62050-00	M4	170	13
				J14	94101-05000	132	25	95002-80000	E6	44	13		M7	173	31
				J14	94101-06000	132	26	95003-09023-31	I10	112	38	96100-62060-00	M7	173	32
				E13	94101-06800	51	20	95005-35150-10	F3	57	23	96100-63050-00	M8	174	13
				I16		118	15	95014-62100	N7	189	7	96211-06000	N5	187	77
				J14	94103-05700	132	27	95700-06020-00	J7	125	24	96211-08000	N5	187	78
				K1		135	22	95700-06055-00	M7	173	29				
				K2	94103-08700	136	11	95700-08022-00	M7	173	30	98000			
				M7	94109-12000	173	26	95700-08032-08	M8	174	10				
				M8		174	9	95700-08035-00	M8	174	11	98079-54841	E6	44	15
				N5	94109-14000	187	57	95701-06008-00	G13	83	13	98079-54846	E6	44	15
				M7	94111-08000	173	27		H5	91	16	98079-54854	E7	45	15
				N5	94251-04000	187	58				18	98079-54855	E7	45	15
				E13	94251-08000	51	21	95701-06010-00	J9	127	10	98079-55841	E7	45	15
				K9		143	28	95701-06012-00	E13	51	22	98079-55846	E7	45	15
				M7	94301-08100	173	28		J14	132	29	98079-55854	E7	45	15
				N5		187	59		K1	135	23	98079-55855	E8	46	15
				F2	94301-08140	56	21		K3	137	13	98079-56841	E7	45	15
				M4		170	12	95701-06012-08	N5	187	64	98079-56846	E7	45	15
				N5	94301-10120	187	60	95701-06016-00	J8	126	14	98079-56854	E9	47	15
				E6	94301-10160	44	12		K2	136	7	98079-56855	E8	46	15
				N5	94302-05080	187	61		N5	187	65				
				F2	94303-08140	56	21	95701-06016-08	N5	187	66				
				M5		171	11	95701-06020-00	I15	117	13	99000			
				H9	94305-20122	95	31		J3	121	11				
				I7		109	33		J5	123	13	99001-10120	M16	182	4
				N5	94305-40282	187	62		J7	125	24		N1	183	11
				N5	94520-30000	187	63		J8	126	15	99001-10140	N2	184	12
								95701-06025-00	K2	136	8	99001-14170	M16	182	5
					95000				K10	144	35		N2	184	14
				K9	95001-45035-40	143	29	95701-06025-08	K13	147	14	99004-21001	N1	183	9
				K9	95001-45075-60	143	30	95701-06032-00	K13	147	15	99008-02300	M16	182	6
				K9	95001-45110-40	143	30		N5	187	68	99101-ZF5-0550	H9	95	32
				K9	95001-45140-40	143	31	95701-06055-00	M7	173	29		I7	109	34
				K13		147	12	95701-08012-00	K2	136	9	99101-ZF5-0580	H9	95	32
				K14		148	9	95701-08018-00	K2	136	10		I7	109	34
				N8	95001-45250-40	190	15	95701-08020-00	K2	136	10	99101-ZF5-0600	H9	95	32
				K9	95001-45300-40	143	31	95701-08022-00	M7	173	30		I7	109	34
				K12		146	19	95701-08032-08	M8	174	10	99101-ZF5-0620	I7	109	34
94001-06000-0S	J1	119	16	K9	95001-45350-40	143	31	95701-08035-00	M5	171	12	99101-ZH7-0550	I7	109	34
94001-08000-0S	J14	132	24	K9		143	29		M8	174	11	99101-ZH7-0580	I7	109	34
	K1	135	21	H10	95001-45400-60	96	36	95701-08045-08	N5	187	69	99101-ZH7-0600	H9	95	32
	K2	136	5	K9		143	31	95701-08055-00	M5	171	13		I7	109	34
	K3	137	6	K9		143	31	95701-08065-00	N5	187	70	99101-ZH7-0620	I7	109	34
94050-06000	I16	118	14	K9	95001-45750-40	143	31	95701-08070-08	N5	187	71	99101-ZH7-0650	I7	109	34
	J3	121	12	F2		56	22	95701-08090-08	N5	187	72				
	J5	123	14	I10		112	37								





# PART NAME INDEX

Part name	Address	Page	Ref.	Part name	Address	Page	Ref.	Part name	Address	Page	Ref.
[ A ]											
ALERT UNIT, OIL .....	G16	86	2	BOLT, DRAIN PLUG, 12X15 .....	M8	174	7	BOLT, FLANGE, 8X35 .....	M8	174	11
			3	BOLT, FLANGE, 10X16 .....	N5	187	73	BOLT, FLANGE, 8X45 .....	N5	187	69
ARM COMP., GOVERNOR .....	H5 L15	91 165	17 34	BOLT, FLANGE, 5X10 .....	L3	153	11	BOLT, FLANGE, 8X55 .....	E6	44	14
			35	BOLT, FLANGE, 6X10 .....	G14	84	13		M5	171	13
ARM COMP., NEUTRAL VALVE .....	N3	185	8		G15	85	16	BOLT, FLANGE, 8X65 .....	N5	187	70
ARM, CLUTCH .....	N4	186	34	BOLT, FLANGE, 6X12 .....	J9	127	10	BOLT, FLANGE, 8X70 .....	N5	187	71
ARM, GOVERNOR .....	L6	156	5		E5	43	9	BOLT, FLANGE, 8X90 .....	N5	187	72
	L16	166	1		E13	51	22	BOLT, GOVERNOR ARM .....	L11	161	23
ARM, VALVE ROCKER .....	M2	168	1		H5	91	14		L16	166	9
ARRESTER, SPARK .....	G2	72	4		J8	126	15	BOLT, HEX., 5/16" .....	F4	58	13
	J11	129	6		J14	132	29	BOLT, HEX., 8X20 .....	K3	137	5
	J16	134	6		K1	135	23	BOLT, HEX., 8X25 .....	F4	58	13
	K3	137	2		K3	137	13		F5	59	13
					L11	161	22		M4	170	11
					L16	166	8		M5	171	10
					M1	167	11		M7	173	24
					M2	168	8	BOLT, HEX., 8X35 .....	M7	173	24
					N5	187	64	BOLT, MUDGUARD .....	J7	125	18
					E5	43	9	BOLT, PIVOT, 8MM .....	G5	75	17
					J14	132	29	BOLT, PLUG, 14MM .....	N4	186	35
					K1	135	13	BOLT, STUD, 10X32 .....	N7	189	2
					F1	55	14	BOLT, STUD, 10X60 .....	N7	189	2
					F1	55	16	BOLT, STUD, 6X109 .....	E5	43	10
					J8	126	14	BOLT, STUD, 6X112 .....	E6	44	10
					K2	136	7	BOLT, STUD, 6X94 .....	E5	43	10
					N5	187	65	BOLT, STUD, 8X32 .....	E6	44	11
							66	BOLT, WINKER SETTING .....	J9	127	8
							15	BOWL SET, CONTROL .....	N3	185	11
							117	BOX, TOOL .....	N1	183	1
							121	BUSH, CONTROL BOWL .....	N4	186	33
							123				
							125				
							125				
							126				
							162				
							166				
							153				
							136				
							144				
							147				
							154				
							187				
							55				
							153				
							154				
							169				
							144				
							148				
							147				
							187				
							173				
							83				
							91				
							16				
							136				
							136				
							136				
							173				
							174				
							171				
							9				
							10				
							10				
							30				
							10				
							12				
							9				
							7				
							18				
							9				
							10				
							10				
							30				
							10				
							12				
							9				
							7				
							17				
							7				
							9				
							5				
							12				
							17				
							10				



# PART NAME INDEX

Part name	Address	Page	Ref.	Part name	Address	Page	Ref.	Part name	Address	Page	Ref.
CARBURETOR ASSY. ....	H14	100	10	CLIP, TUBE .....	K13	147	13	COVER COMP., MUFFLER RR. ....	K1	135	10
	H15	101	10		K14	148	10	COVER, AIR CLEANER .....	I12	114	4
	H16	102	10		N8	190	16		J2	120	3
CASE COMP., AIR CLEANER .....	J9	127	4	CLIP, VALVE GUIDE .....	E2	40	4		J6	124	5
CASE COMP., PUMP .....	N3	185	14	CLIP, WATER HOSE .....	J8	126	16		J9	127	5
CASE COMP., RECOIL STARTER ...	G8	78	2		K9	143	27	COVER, GENERATOR FAN .....	N9	191	3
	G9	79	2	CLIP, WIRE HARNESS .....	H5	91	21	COVER, MUFFLER .....	J12	130	10
	G15	85	2		N7	189	18	COVER, REDUCTION .....	M6	172	3
CASE COMP., RR. TRANSMISSION -	N3	185	2	COCK ASSY., FUEL .....	K12	146	3		M8	174	3
CASE, PRE AIR CLEANER .....	J6	124	11		N8	190	3	CRANKSHAFT COMP. ....	F4	58	1
CASE, RECOIL STARTER SPRING ..	G15	85	10	COIL ASSY., IGNITION .....	L2	152	1				
CASE, REDUCTION .....	M6	172	1		L3	153	1				
	M8	174	1	COIL ASSY., LAMP .....	L3	153	3				
CENTER, CLUTCH .....	M6	172	5				4				
CENTER, CLUTCH WEIGHT .....	M6	172	13				5				
CHAIN, DRIVE .....	M6	172	15	COLLAR B, AIR CLEANER .....	I13	115	8				
CHAIN, P.T.O. DRIVE .....	M3	169	3		J3	121	5				
	M5	171	3		J4	122	3				
CHAMBER SET, FLOAT .....	H6	92	5		J6	124	9				
	H12	98	5		J8	126	9				
	H13	99	5	COLLAR, AIR CLEANER .....	I13	115	7				
CHOKE KIT, REMOTE CONTROL ----	H6	92	1		J2	120	4				
	H11	97	1		J4	122	2		F5	59	16
CHOKE SET .....	H7	93	9		J6	124	8				
	H14	100	9		J8	126	8				
CIRCLIP, 5MM .....	H9	95	27	COLLAR, AIR CLEANER CASE .....	J10	128	1	CUP, FUEL STRAINER .....	I5	107	28
	I5	107	29		J16	134	1		K12	146	7
	L13	163	28	COLLAR, BEVEL GEAR .....	N5	187	56		N8	190	2
CIRCLIP, INTERNAL, 30MM .....	N5	187	63	COLLAR, CONTROL BOX .....	N8	190	13	CUSHION, C.D.I. UNIT .....	N9	191	10
CLAMPER, CORD .....	H2	88	8	COLLAR, FUEL TANK .....	K13	147	10				
	L3	153	6	COLLAR, LEVER .....	L15	165	36	[ D ]			
CLAMP D, 19MM .....	N6	188	5	COLLAR, STOPPER .....	L11	161	19	DEFLECTOR COMP. ....	J11	129	5
CLAMP, CORD .....	H2	88	8		L15	165	37		N7	189	12
CLAMP, SWITCH CORD .....	F3	57	24		L16	166	7	DEFLECTOR, MUFFLER .....	J12	130	8
	J1	119	17	COLLAR, TANK CUSHION .....	K12	146	17		K1	135	8
CLAMP, TUBE .....	H10	96	37	COLLAR, WEIGHT CENTER .....	G5	75	20	DISK, CLUTCH FRICTION .....	M6	172	6
	K10	144	37	CONTROL ASSY. ....	L5	155	1	DOWEL PIN, 10X12 .....	N5	187	60
			38					DOWEL PIN, 10X16 .....	E6	44	12
	N7	189	17		L6	156	3	DOWEL PIN, 3X5.8 .....	N4	186	43
	N9	191	8					DOWEL PIN, 8X10 .....	M7	173	28
CLAMP, TUBE, 7.5X2 .....	K9	143	26		L16	166	5		N5	187	59
CLEANER ASSY., AIR .....	J8	126	2	CONTROL UNIT, ENGINE .....	N9	191	12	DOWEL PIN, 8X14 .....	F2	56	21
CLIP A, WIRE .....	J8	126	4	CORD, CLUTCH SWITCH .....	N9	191	11		M4	170	12
CLIP B, CORD .....	J1	119	17	CORD, STOP SWITCH .....	H4	90	12	DUST SEAL, 9X15X5 .....	M5	171	11
CLIP B, TUBE .....	J1	119	18	COVER ASSY., CHAIN CASE .....	M3	169	1		N5	187	49
	J8	126	1		M5	171	1	[ E ]			
CLIP B, WIRE .....	J8	126	5	COVER ASSY., CRANKCASE .....	E14	52	1	ELBOW COMP., AIR CLEANER .....	I14	116	9
CLIP, BEARING .....	N4	186	42		E15	53	1		J3	121	6
CLIP, DOUBLE .....	K9	143	26				2		J4	122	8
CLIP, GOVERNOR HOLDER .....	E11	49	15	COVER COMP., AIR CLEANER .....	J8	126	7		J6	124	10
CLIP, HARNESS .....	H5	91	22	COVER COMP., FAN .....	G16	86	4	ELEMENT COMP., AIR CLEANER .....	J8	126	3
CLIP, PISTON PIN, 13MM .....	G1	71	6		H1	87	4	ELEMENT, AIR CLEANER .....	I11	113	2
CLIP, TUBE .....	E6	44	13				5		J2	120	1
	F2	56	22	COVER COMP., HEAD .....	E3	41	6		J4	122	6
	I10	112	37		E4	42	6		J4	122	6
	K9	143	32	COVER COMP., MUFFLER .....	J12	130	9		J6	124	2
			33	COVER COMP., MUFFLER RR. ....	K1	135	9				
			34		J12	130	11				
	K12	146	20								



# PART NAME INDEX

Part name	Address	Page	Ref.	Part name	Address	Page	Ref.	Part name	Address	Page	Ref.
ELEMENT, AIR CLEANER .....	J9	127	2	GUIDE, GENERATOR AIR .....	N9	191	2	[ L ]			
EMBLEM .....	M9	175	2	GUIDE, IN. VALVE .....	E1	39	2	LABEL, AIR CLEANER CAUTION .....	M13	179	13
	M10	176	2		E2	40	2	LABEL, CAUTION .....	M15	181	28
	M11	177	2	GUIDE, MUFFLER .....	J13	131	14	LABEL, E-SPEC .....	M9	175	1
	M12	178	7		N7	189	13	LABEL, PRE AIR CLEANER .....	M14	180	21
EMBLEM, UPPER .....	M9	175	1	GUIDE, PRE AIR CLEANER .....	J6	124	13	LABEL, FUEL CAUTION .....	M15	181	30
END, LOCK .....	L11	161	20	GUIDE, RATCHET .....	G11	81	5	LABEL, FUEL WARNING .....	M11	177	3
					G15	85	9	LABEL, OPERATOR WARNING .....	M14	180	22
[ F ]				[ H ]				LABEL, SPEC .....	M15	181	32
FAN, COOLING .....	K15	149	2	HANDLE, BOX WRENCH .....	M16	182	3	LABEL, SPECIFICATION .....	M12	178	6
	N9	191	4		N1	183	10		M13	179	14
FILTER ASSY., SUCTION .....	N3	185	22	HEAD COMP., CYLINDER .....	E1	39	1		M14	180	14
FILTER COMP., FUEL .....	K7	141	17	HOLDER COMP., OIL SEAL .....	N3	185	4	LEVER COMP., CHOKE .....	H8	94	19
	K12	146	12	HOLDER, BEARING .....	N3	185	7		I3	105	20
FILTER, CUP .....	K12	146	6		N4	186	29		I3	105	20
FILTER, FUEL .....	K7	141	17	HOLDER, CABLE .....	H8	94	22		I3	105	21
			18		I3	105	23		H8	94	23
	K13	147	9		L9	159	12	LEVER, COCK .....	I3	105	24
	K14	148	6	HOLDER, CLUTCH SPRING .....	M6	172	10	LEVER, CONTROL .....	L7	157	9
	N8	190	9	HOLDER, CLUTCH WEIGHT .....	M6	172	12		L8	158	9
FILTER, OUTER .....	I12	114	3	HOLDER, CONTROL CABLE .....	H8	94	17	LIFTER, VALVE .....	G3	73	5
	J6	124	3		I3	105	18				
	J8	126	6	HOLDER, FUEL FILTER .....	K7	141	19	[ M ]			
FILTER, SUCTION .....	N3	185	23	HOLDER, GOVERNOR WEIGHT .....	E11	49	6	MARK A, COMBINATION .....	M13	179	8
FLOAT SET .....	H6	92	4	HOLDER, STOP SWITCH CORD .....	H5	91	19	MARK B, COMBINATION .....	M14	180	23
	H12	98	4	HOLDER, WIRE .....	L11	161	18	MARK, AIR CLEANER .....	M14	180	16
FLYWHEEL COMP. ....	K16	150	5	HOUSING, TROCHOID .....	N3	185	21	MARK, AIR CLEANER CAUTION .....	M11	177	4
	L1	151	5					MARK, AIR CLEANER SALES POINT .....	M15	181	27
			6	[ I ]				MARK, CAUTION .....	M11	177	3
[ G ]				INSULATOR, CARBURETOR .....	H7	93	13		M12	178	6
GASKET KIT .....	N10	192	1		I1	103	14	MARK, CHOKE .....	M11	177	5
GASKET SET .....	H6	92	2	[ J ]				MARK, ENGINE OPERATION .....	M12	178	5
	H11	97	2	JET SET, PILOT, .....	H9	95	33	MARK, EX. CAUTION .....	M14	180	17
GASKET, CYLINDER HEAD .....	E2	40	5		I9	111	35	MARK, FIRE DANGER .....	M14	180	15
	E3	41	5	JET, MAIN, .....	H9	95	32	MARK, FUEL .....	M15	181	24
GASKET, MUFFLER .....	J12	130	7		I7	109	34	MARK, FUEL CAUTION .....	M11	177	3
	J16	134	7	JOINT, DRAIN .....	N7	189	15	MARK, FUEL WARNING .....	M15	181	26
	K2	136	4	JOINT, FUEL .....	K4	138	6				
	K3	137	3	JOINT, FUEL TANK .....	K5	139	9	MARK, HEAT CAUTION .....	M15	181	33
			4		K14	148	2	MARK, OIL ALERT .....	M13	179	8
GAUGE ASSY., FUEL .....	K10	144	40	JOINT, ROD .....	L15	165	38				10
GAUGE ASSY., THICKNESS .....	N1	183	7								12
GAUGE COMP., OIL LEVEL .....	E16	54	8	[ K ]				MARK, OIL CAUTION .....	M13	179	14
GAUGE, OIL LEVEL .....	M6	172	18	KEY, 4.78X4.78X38 .....	F5	59	15		M15	181	35
GEAR SET, MOTOR SHAFT & BEVEL	N3	185	12	KEY, 5MM .....	M6	172	20	MARK, THROTTLE INDICATION .....	M13	179	11
GOVERNOR ASSY. ....	E11	49	4	KEY, 5X5X33 .....	F5	59	15		M14	180	20
GRID, AIR CLEANER .....	J2	120	2		M4	170	9	MARK, TOP .....	M9	175	1
	J4	122	7	KEY, 7X7X33 .....	M6	172	21	MARK, USE FUEL .....	M15	181	25
GRIP .....	N1	183	5	KEY, SPECIAL WOODRUFF, 25X18 ..	K15	149	1				34
GRIP, STARTER .....	G13	83	9	KNOB, RECOIL STARTER .....	G15	85	14	METER ASSY., FUEL .....	K12	146	8
GROMMET, ADJUSTING COVER .....	G16	86	1								
GROMMET, AIR CLEANER .....	I13	115	5								
	J6	124	7								
GROMMET, CORD .....	L3	153	7								
GROMMET, DRAIN HOLE .....	H4	90	13								
GUIDE, EX. VALVE .....	E2	40	3								

# PART NAME INDEX

Part name	Address	Page	Ref.	Part name	Address	Page	Ref.	Part name	Address	Page	Ref.
METER ASSY., FUEL .....	N8	190	5	NUT, WING, 6MM .....	J3	121	9	PACKING, PUMP CASE .....	N3	185	15
MUFFLER ASSY. ....	J14	132	28		J5	123	11	PACKING, REDUCTION CASE .....	M6	172	2
MUFFLER COMP. ....	J10	128	2		J7	125	17		M8	174	2
	J15	133	31	[ O ]				PACKING, REDUCTION COVER .....	M6	172	4
	J16	134	2						M8	174	4
	K1	135	24					PACKING, RR. TRANSMISSION CASE	N3	185	3
	K2	136	1	OIL SEAL .....	M6	172	22	PAN, CLEANER OIL .....	J4	122	5
	K3	137	1	OIL SEAL, 15X28X7 .....	N5	187	50	PIN B, DOWEL, 5X8 .....	N5	187	61
[ N ]				OIL SEAL, 17X30X6 .....	N5	187	48	PIN, GOVERNOR WEIGHT .....	E11	49	7
NOSE, SILENCER .....	I13	115	6	OIL SEAL, 22X35X6 .....	E12	50	17	PIN, LOCK, 4MM .....	N5	187	58
NOZZLE, MAIN .....	H7	93	12	OIL SEAL, 22X41X6 .....	F1	55	18	PIN, LOCK, 8MM .....	E13	51	21
	H16	102	12		F2	56	18		K9	143	28
	I1	103	12	OIL SEAL, 25X38X7 .....	M5	171	9	PIN, NEUTRAL VALVE .....	N4	186	44
	G15	85	13	OIL SEAL, 25X41X6 .....	M4	170	10	PIN, PISTON .....	G1	71	3
NUT .....	I14	116	11		M8	174	8	PIN, SPRING, 2X12 .....	H9	95	31
NUT, AIR CLEANER COVER .....	J3	121	9	O-RING .....	K12	146	5		I7	109	33
	J5	123	11	O-RING, 11X1.9 .....	N5	187	53	PIN, SPRING, 4X28 .....	N5	187	62
	J7	125	17	O-RING, 11.8X1.9 .....	N5	187	55	PIN, STARTER RATCHET .....	G15	85	5
NUT, CAP, 6MM .....	J5	123	11	O-RING, 14MM .....	E13	51	18	PIN, WEIGHT CENTER .....	G5	75	19
	J7	125	17		K8	142	24	PIPE COMP., EX. ....	K3	137	10
	J3	121	8		K14	148	7	PIPE COMP., OIL .....	F1	55	12
	J5	123	10	O-RING, 15.8X2.4 .....	F2	56	20	PISTON .....	F14	68	2
	J7	125	16	O-RING, 16MM .....	F2	56	19		F15	69	2
NUT, FLANGE, 10MM .....	E13	51	19	O-RING, 25X2.4 .....	N5	187	51		F16	70	2
	N7	189	5	O-RING, 26X2.7 .....	M7	173	23		G1	71	2
NUT, FLANGE, 6MM .....	I16	118	14	O-RING, 34.6X1.9 .....	N5	187	52	PISTON, PUMP .....	N3	185	17
	J3	121	12	O-RING, 5.8X1.9 .....	N5	187	54	PIVOT, ROCKER ARM .....	G4	74	6
	J5	123	14	[ P ]				PLATE COMP., CLUTCH PRESSURE ..	M6	172	8
	J7	125	23	PACKING SET, COCK .....	N8	190	1	PLATE COMP., DISTRIBUTOR .....	N4	186	28
	J8	126	13	PACKING, AIR CLEANER .....	J9	127	1	PLATE COMP., SIDE .....	H1	87	6
	J9	127	9	PACKING, AIR CLEANER COVER .....	J6	124	4		H2	88	7
	K2	136	6	PACKING, CARBURETOR .....	H8	94	16	PLATE SET, MOTOR CYLINDER .....	N3	185	10
	K3	137	12		I2	104	17	PLATE SET, PUMP CYLINDER .....	N3	185	9
	K8	142	25	PACKING, CASE COVER .....	I3	105	17	PLATE, CLUTCH .....	M6	172	7
	K13	147	11	PACKING, CHAIN CASE .....	E15	53	3	PLATE, EMBLEM .....	M9	175	2
	K14	148	8	PACKING, CHAIN CASE COVER .....	M3	169	2	PLATE, FAN SETTING .....	N9	191	1
	L15	165	33		M3	169	2	PLATE, FILTER CAP .....	N3	185	25
	M1	167	13	PACKING, ELBOW .....	M5	171	2	PLATE, FRICTION .....	G15	85	6
	M2	168	11		I11	113	1	PLATE, FUEL INDICATION .....	K12	146	15
NUT, FLANGE, 8MM .....	J14	132	24	PACKING, FUEL CAP .....	K13	147	8		M14	180	18
NUT, HEX., 5MM .....	J13	131	20	PACKING, FUEL COCK .....	H9	95	26	PLATE, LEVER SETTING .....	H8	94	24
	K1	135	19		I5	107	27	PLATE, PRE AIR CLEANER .....	I4	106	25
NUT, HEX., 6MM .....	J1	119	16	PACKING, FUEL FILLER CAP .....	K7	141	16		J6	124	14
NUT, HEX., 8MM .....	J14	132	24		K11	145	44	PLATE, PUSH ROD GUIDE .....	J7	125	15
	K1	135	21	PACKING, FUEL STRAINER CUP .....	K12	146	11	PLATE, SIDE .....	H1	87	6
	K2	136	5		K14	148	5		H2	88	7
	K3	137	6	PACKING, HEAD COVER .....	N8	190	8	PLUG, SPARK .....	E6	44	15
NUT, OIL FILLER .....	F1	55	13	PACKING, INSULATOR .....	H7	93	14		E7	45	15
NUT, PIVOT ADJUSTING .....	G5	75	18		I1	103	15		E8	46	15
NUT, SELF-LOCK, 6MM .....	L13	163	26	PACKING, OIL FILLER CAP .....	F1	55	10	PROTECTOR, LOWER .....	E9	47	15
NUT, SPECIAL, 14MM .....	L1	151	7					PROTECTOR, MUFFLER .....	J11	129	4
NUT, TOOL BOX SETTING .....	I15	117	12					PROTECTOR, MUFFLER INNER .....	J11	129	3
	J3	121	10						J16	134	4
	J5	123	12	PACKING, HEAD COVER .....	E4	42	7	PROTECTOR, MUFFLER OUTER .....	K3	137	8
	J7	125	20	PACKING, INSULATOR .....	H7	93	14	PROTECTOR, OIL TUBE .....	J16	134	4
			21		I1	103	15	PROTECTOR, TAIL PIPE .....	K3	137	7
NUT, U, 6MM .....	J7	125	19						N6	188	2
NUT, WING, 6MM .....	I15	117	11						J15	133	32



# PART NAME INDEX

Part name	Address	Page	Ref.	Part name	Address	Page	Ref.	Part name	Address	Page	Ref.
PROTECTOR, UPPER .....	J11	129	3	[ S ]				SCREW, TAPPING, 5X25 .....	J13	131	17
PULLEY COMP., STARTER .....	K15	149	3	SCREEN SET .....	K4	138	8	SCREW, TAPPING, 5X8 .....	K1	135	16
PULLEY, RECOIL STARTER .....	G15	85	3	SCREEN, FUEL STRAINER .....	N8	190	4	SCREW, TAPPING, 5X8 .....	J13	131	15
PULLEY, STARTER .....	K16	150	4	SCREW-WASHER, 4X12 .....	K12	146	4				
PULLEY, WHEEL DRIVEN .....	N3	185	5	SCREW-WASHER, 5X16 .....	J7	125	22				
				SCREW-WASHER, 6X20 .....	L14	164	32	SCREW, TAPPING, 6X16 .....	J14	132	23
				SCREW-WASHER, 6X20 .....	J13	131	22	SCREW, THROTTLE STOP .....	H7	93	11
					K1	135	20		H16	102	11
[ R ]				SCREW SET .....	H7	93	8	SEAL, AIR CLEANER .....	J9	127	7
RATCHET, STARTER .....	G9	79	4	SCREW SET, DRAIN .....	H13	99	8	SEAL, MUFFLER PROTECTOR .....	K3	137	9
	G10	80	4		H7	93	7	SEAL, RUBBER .....	N3	185	24
	G15	85	4	SCREW SET, PILOT .....	H13	99	7	SEAL, VALVE STEM .....	G6	76	21
REEL, RECOIL STARTER .....	G9	79	3		H6	92	6	SEAT, RELIEF VALVE .....	N4	186	27
RETAINER, EX. VALVE SPRING ...	G5	75	14	SCREW, FLAT, 5X10 .....	H10	96	34	SEPARATOR, AIR CLEANER .....	J9	127	3
RETAINER, IN. VALVE SPRING ...	G5	75	13		H13	99	6	SHAFT COMP., P.T.O. ....	M6	172	16
RING SET, PISTON .....	F6	60	1	SCREW, LOCK PAN .....	I10	112	36	SHAFT, CROSS .....	N3	185	6
	F7	61	1		K10	144	42	SHAFT, GOVERNOR ARM .....	E11	49	9
	F8	62	1	SCREW, PAN, 3X6 .....	K12	146	18	SHAFT, PUMP .....	N3	185	16
	F9	63	1		N8	190	14	SHAFT, P.T.O. ....	M3	169	5
	F10	64	1	SCREW, PAN, 3X8 .....	L13	163	27		M5	171	5
	F11	65	1		H9	95	28	SHAFT, SCREW DRIVER .....	N1	183	4
	F12	66	1	SCREW, PAN, 4X20 .....	I6	108	30	SHAFT, SUB .....	G15	85	12
	F13	67	1	SCREW, PAN, 4X6 .....	H9	95	28	SHIM A, BEVEL GEAR .....	N4	186	41
	F14	68	1	SCREW, PAN, 4X8 .....	I5	107	30	SHIM B, BEVEL GEAR .....	N4	186	41
RING, SEAL .....	N7	189	11	SCREW, PAN, 5X10 .....	J8	126	17	SHIM C, BEVEL GEAR .....	N4	186	41
ROD ASSY., CONNECTING .....	G1	71	4	SCREW, PAN, 5X16 .....	L13	163	29	SHIM D, BEVEL GEAR .....	N4	186	41
ROD, GOVERNOR .....	L7	157	6	SCREW, PAN, 5X25 .....	H9	95	29	SHIM E, BEVEL GEAR .....	N4	186	41
	L15	165	39		I6	108	31	SHIM F, BEVEL GEAR .....	N4	186	41
	L16	166	2	SCREW, PAN, 5X28 .....	J13	131	21	SHROUD COMP. ....	H3	89	9
ROD, PUSH .....	M2	168	2	SCREW, PAN, 5X30 .....	L14	164	32	SLIDER, GOVERNOR .....	E11	49	8
ROLLER, 2.5X11.8 .....	N5	187	47	SCREW, PAN, 5X35 .....	L13	163	31	SPACER COMP., CARBURETOR .....	H7	93	15
ROPE, RECOIL STARTER .....	G13	83	10	SCREW, PAN, 5X8 .....	M2	168	10		I1	103	16
	G15	85	15		L13	163	30	SPACER, CONTROL LEVER .....	L9	159	13
	G13	83	11	SCREW, RECESSED, 5X25 .....	L13	163	30	SPACER, MUFFLER COVER .....	J13	131	13
ROPE, STARTER .....	G13	83	11		M1	167	12		K1	135	12
ROTATOR, VALVE .....	G5	75	15	SCREW, RECESSED, 5X28 .....	H9	95	30	SPANNER, 10X12 .....	M16	182	4
ROTOR, TROCHOID .....	N3	185	19		I6	108	32	SPANNER, 10X14 .....	N1	183	11
RUBBER, BOTTOM .....	E13	51	23	SCREW, RECESSED, 5X28 .....	L12	162	24	SPANNER, 14X17 .....	N2	184	12
	K12	146	14	SCREW, SETTING .....	L13	163	30	SPANNER, 14X17 .....	M16	182	5
	N9	191	9	SCREW, TAPPING, 3X8 .....	L16	166	10	SPONGE, FUEL CAP BREATHER .....	N2	184	14
RUBBER, CONTROL BOX .....	N8	190	11	SCREW, TAPPING, 4X6 .....	L11	161	24	SPPOOL, NEUTRAL VALVE .....	K13	147	7
RUBBER, FR. BOTTOM .....	E11	49	10		L16	166	10	SPRING, CABLE RETURN .....	N4	186	30
RUBBER, FUEL .....	K7	141	23	SCREW, TAPPING, 5X14 .....	G13	83	12	SPRING, CHECK VALVE .....	L11	161	17
	K8	142	23	SCREW, TAPPING, 5X18 .....	N7	189	4	SPRING, CLUTCH FREE .....	M2	168	7
	N8	190	12		J13	131	18	SPRING, COCK LEVER .....	H9	95	25
RUBBER, RR. BOTTOM .....	E11	49	11	SCREW, TAPPING, 5X14 .....	J15	133	30	SPRING, CONTROL ADJUSTING .....	I5	107	26
RUBBER, SUPPORTER .....	H10	96	35	SCREW, TAPPING, 5X18 .....	K1	135	17	SPRING, CONTROL ADJUSTING .....	L10	160	16
	K4	138	1		N7	189	14	SPRING, CONTROL ADJUSTING .....	L16	166	6
	K12	146	2	SCREW, TAPPING, 5X14 .....	N7	189	14	SPRING, CONTROL ADJUSTING .....	M2	168	6
	K13	147	1	SCREW, TAPPING, 5X18 .....	J13	131	19	SPRING, FRICTION .....	G11	81	6
	K14	148	1		K1	135	18	SPRING, FRICTION .....	G15	85	7
RUBBER, TANK CUSHION .....	K7	141	20	SCREW, TAPPING, 5X14 .....	N7	189	14	SPRING, GOVERNOR .....	L7	157	7
	K12	146	16	SCREW, TAPPING, 5X18 .....	N9	191	5		L16	166	3
RUBBER, TANK MOUNTING .....	K12	146	13		N9	191	6		M2	168	3
	N8	190	10								
RUBBER, TANK SETTING .....	K13	147	2								
			3								



# PART NAME INDEX

Part name	Address	Page	Ref.	Part name	Address	Page	Ref.	Part name	Address	Page	Ref.
SPRING, LEVER .....	L8	158	10	TUBE, AIR CLEANER CONNECTING ..	J8	126	10	WIRE, LOCK .....	L11	161	21
SPRING, PISTON .....	N3	185	18	TUBE, BREATHER .....	E5	43	8	WRENCH COMP., SPARK PLUG .....	M16	182	2
SPRING, RECOIL STARTER .....	G11	81	7	TUBE, DRAIN .....	N7	189	16		N1	183	9
	G15	85	8	TUBE, FUEL, 4.5X110 .....	K9	143	30	WRENCH, BOX .....	N1	183	8
SPRING, RELIEF VALVE .....	N4	186	26	TUBE, FUEL, 4.5X140 .....	K9	143	31				
SPRING, RETURN .....	G12	82	8		K13	147	12	WRENCH, PLUG .....	N1	183	8
	H8	94	21		K14	148	9				
	I3	105	22	TUBE, FUEL, 4.5X250 .....	N8	190	15				
SPRING, THROTTLE RETURN .....	L7	157	8	TUBE, FUEL, 4.5X300 .....	K9	143	31				
	L16	166	4		K12	146	19				
	M2	168	4	TUBE, FUEL, 4.5X35 .....	K9	143	29				
SPRING, THRUST .....	M4	170	7	TUBE, FUEL, 4.5X350 .....	K9	143	29				
	M5	171	7								
SPRING, VALVE .....	G5	75	12	TUBE, FUEL, 4.5X400 .....	H10	96	36				
SPRING, WEIGHT RETURN .....	G5	75	8		K9	143	31				
				TUBE, FUEL, 4.5X75 .....	K9	143	30				
SPROCKET COMP., DRIVE .....	M6	172	14	TUBE, FUEL, 4.5X750 .....	K9	143	31				
SPROCKET, DRIVE .....	M3	169	4	TUBE, OIL .....	N6	188	1				
	M5	171	4	TUBE, VINYL, 4.5X8X230 .....	I10	112	38				
STARTER ASSY., RECOIL .....	G7	77	1								
	G8	78	1	[ V ]							
	G15	85	1	VALVE SET, FLOAT .....	H6	92	3				
STAY COMP., MUFFLER .....	K2	136	2		H11	97	3				
				VALVE, EX. ....	G5	75	11				
STAY, AIR CLEANER .....	J9	127	6	VALVE, IN. ....	G5	75	10				
STAY, CHOKE CONTROL .....	H8	94	18	VANE, TROCHOID .....	N3	185	20				
	I3	105	19								
STAY, CORD CLIP .....	F3	57	28	[ W ]							
	H5	91	20	WASHER, 6X17 .....	N4	186	37				
STAY, FUEL TANK .....	K13	147	5	WASHER, 8MM .....	F5	59	14				
STAY, MUFFLER .....	J16	134	3		M4	170	8				
	K3	137	11		M5	171	8				
STRAINER COMP., FUEL .....	K4	138	5	WASHER, AIR DUCT .....	K7	141	21				
				WASHER, CAMSHAFT SIDE .....	N4	186	36				
	N9	191	7	WASHER, CONTROL LEVER .....	L9	159	11				
SUB HARNESS .....	H3	89	10	WASHER, DRAIN PLUG, 10.2MM .....	E11	49	14				
SWITCH ASSY., CLUTCH .....	N9	191	13	WASHER, DRAIN PLUG, 12MM .....	M7	173	26				
SWITCH ASSY., ENGINE STOP .....	H3	89	11		M8	174	9				
	N7	189	1	WASHER, DRAIN PLUG, 14MM .....	N5	187	57				
SWITCH ASSY., OIL LEVEL .....	E11	49	3	WASHER, PLAIN, 15MM .....	N4	186	40				
				WASHER, PLAIN, 5MM .....	J14	132	25				
[ T ]											
TANK ASSY., FUEL .....	K10	144	39		K1	135	22				
TANK ASSY., OIL .....	E15	53	4	WASHER, PLAIN, 6MM .....	E13	51	20				
	N6	188	3		I16	118	15				
TANK COMP., FUEL .....	K5	139	12		J14	132	26				
	K12	146	9	WASHER, PLAIN, 8MM .....	K2	136	11				
	K13	147	4	WASHER, SEALING, 9X16X1.5 .....	N4	186	38				
	K14	148	3	WASHER, SPRING, 8MM .....	M7	173	27				
TERMINAL ASSY., HIGH TENSION .....	N8	190	6	WASHER, STARTER .....	G15	85	11				
TOOL KIT .....	L3	153	2	WASHER, THRUST, 18MM .....	M6	172	19				
	M16	182	1	WASHER, THRUST, 20X1.00 .....	M5	171	6				
	N1	183	3	WASHER, THRUST, 6MM .....	E11	49	13				
	N2	184	15	WASHER, THRUST, 8MM .....	N4	186	39				
TRANSMISSION ASSY. ....	N3	185	1	WEIGHT COMP., DECOMPER .....	G4	74	7				
TUBE .....	K4	138	3	WEIGHT, CLUTCH .....	M6	172	11				
TUBE A, AIR VENT .....	K4	138	2	WEIGHT, GOVERNOR .....	E11	49	5				
TUBE, 3.5X150 .....	F3	57	23								

---

**1**

**FOREWORD INDEX**

---

**2**

**ENGINE GROUP**

---

**3**

**PART NUMBER INDEX**

---

**4**

**PART NAME INDEX**

---

**HONDA**  
The Power of Dreams





# PARTS CATALOGUE NEWS

Honda Motor Co., Ltd. Service Division

## PARTS CATALOGUE - CORRECTED

Printed in Japan

CODE NO.	BOOKLET TYPE	13ZH70E9
	MICRO-FICHE	13ZH70EI/FI
PARTS CATALOGUE TITLE	GX120K1	
NEWS NO.	001	

Block No.	Ref. No.	Note	Part No.	Description	Reqd. QTY				Serial No.	Parts catalogue code
					(1)	(2)	(3)	(4)		
E-17	12	T	17510-ZE0-020ZA	TANK COMP., FUEL *NH31*. . . . . MCKINLEY WHITE	1	-	-	-	-----	DS, HH, HHQ4, HTF2, HT2, HX, HXQ, HXU, HX2, HX26, HX4, LAJ4 LD, LDB1, LDB3, LD4, LE, LH, LHQ4, LJ, LJC, LJS, LJT, LSJ LSJ4, LTA, LTJ, LTK1, LW2, LX, LXU, LX2, LX26, LX4, PH, PM PM2, PX, QA, QAA2, QA2, QA26, QBU2, QD, QE, QH, QHQ4, QH2 QH26, QJW1, QLL, QM, QMA4, QMA8, QME4, QMH, QMX2, QPU, QSJ QT, QTC2, QWA4, QX, QXC, QXC9, QXG, QXG2, QXQ, QXS, QXS2, QXU QX2, QX26, QX4, QX7, RD, RD4, RH, RHQ4, RX, RX4, SAD2, SAJ SAJ4, SCJ, SD, SDB1, SDB3, SD16, SD4, SE, SH, SHQ4, SJ, SJC SJC1, SJC5, SMA7, SMW2, SN, STP, STS, SW2, SX, SXS4, SX4, SX7 TH, TX, TX2, TX26, TX4, UH, UX, UXU, VA, VED, VED1, VED6, VET VEX, VEX7, VH, VMS4, VS, V SX, V SX1, VX, VXU, VX4, VX7, WDA6 WDJ, WD12, WJ, WJP, WJP1, WKD6, WKT2, WKT4, WKT6, WMA3, WME2 WME4
										- (1) 1 1
	E		17510-ZF0-T00ZA	*PARTS NO. DELETION						

NOTE A:PART NO. CHANGE D:NEWLY PROVIDED E:PART NO.DELETION K:REQUIRED NO. CORRECTION L:APPLICATION SERIAL NO. CORRECTION  
T:APPLICATION CORRECTION Z:REMARKS CHANGE



# PARTS CATALOGUE NEWS

Honda Motor Co., Ltd. Service Division

## PARTS CATALOGUE - CORRECTED

Printed in Japan

CODE NO.	BOOKLET TYPE	13ZH70E9
	MICRO-FICHE	13ZH70EI/FI
PARTS CATALOGUE TITLE	GX120K1	
NEWS NO.	002	

Block No.	Ref. No.	Note	Part No.	Description	Reqd. QTY				Serial No.	Parts catalogue code
					(1)	GX120K1 (2)	(3)	(4)		
E-11	1		28400-ZH8-R10ZA	STARTER ASSY., RECOIL (TURFCO) *R8*..... BRIGHT RED	1	-	-	-	----- 4142769	LAJ4
	A		28400-ZH8-R10ZD	*R280*..... POWER RED	1	-	-	-	4142770 -----	LAJ4
	2	L	28410-ZH8-003ZA	CASE COMP., RECOIL STARTER *R8*..... BRIGHT RED	1	(1)	-	-	----- -----	EN, ET, ETX, HH, HXQ, LDB1, LDB3, LD4, LE, LEH4, LJT, LTA, LW2, LX26, PH, PM, PM2, QAA2, QA26, QBU2, QE, QEH, QH2, QJW1, QMH, QPU, QSJ, QTC2, QWA4, QXC, QXG, QXG2, QXQ, QXS, RH, SAD2, SDB1, SDB3, SJC, SKJ, SKR, SN, SW2, S1, TH, UH, UX, U1, VA, VAX4, VH, VMT, VS, VS1, V1, WDJ, WJ1, WM1, W1
					1	(1)	-	-	----- 4142273	AR, DKR, DS, HHQ4, HTF2, HT2, HX, HXU, HX2, HX26, HX4, H1, KR, KRA4, KRF4, KRS4, KRT, KRT4, KRT6, LD, LH, LHQ4, LJ, LJC, LJS, LSJ, LSJ4, LTJ, LTK1, LTR, LX, LXU, LX2, LX4, L1, PX, QA, QA2, QD, QH, QHQ4, QH26, QLL, QM, QMA4, QMA8, QME4, QMX2, QX, QXC9, QXS2, QXU, QX2, QX26, QX4, QX7, Q1, RD, RD4, RHC, RHQ4, RX, RX4, R1, SAJ, SAJ4, SCJ, SD, SD16, SD4, SE, SH, SHQ4, SJ, SJC1, SJC5, SMA7, SMJ, SMW2, STP, STS, SX, SXS4, SX4, SX7, TX, TX2, TX26, TX4, UXU, VED, VED1, VET, VEX, VEX7, VMS4, VPR4, VSX, VSX1, VX, VXU, VX4, VX7, WDA6, WD12, WJ, WJP, WKD6, WKT2, WKT4, WKT6, WMA3, WME2, WME4
					1	-	-	-	----- 3463997	QT
					1	-	-	-	----- 4142769	LAJ4

NOTE A:PART NO. CHANGE D:NEWLY PROVIDED E:PART NO.DELETION K:REQUIRED NO. CORRECTION L:APPLICATION SERIAL NO. CORRECTION  
T:APPLICATION CORRECTION Z:REMARKS CHANGE

PARTS CATALOGUE NEWS

BOOKNo. : 13ZH70E9

Block No.	Ref. No.	Note	Part No.	Description	Reqd. QTY				Serial No.	Parts catalogue code	
					(1)	GX120K1 (2)	(3)	(4)			
					-	-	1	1			
		T	28410-ZH8-003YA	*R280*.....POWER RED	1	(1)	-	-	4142274	-----	AR, DKR, DS, HHQ4, HTF2, HT2, HX, HXU, HX2, HX26, HX4, H1, KR KRA4, KRF4, KRS4, KRT, KRT4, KRT6, LD, LH, LHQ4, LJ, LJC, LJS LSJ, LSJ4, LTJ, LTK1, LTR, LX, LXU, LX2, LX4, L1, PX, QA, QA2 QD, QH, QHQ4, QH26, QLL, QM, QMA4, QMA8, QME4, QMX2, QX, QXC9 QXS2, QXU, QX2, QX26, QX4, QX7, Q1, RD, RD4, RHC, RHQ4, RX RX4, R1, SAJ, SAJ4, SCJ, SD, SD16, SD4, SE, SH, SHQ4, SJ, SJC1 SJC5, SMA7, SMJ, SMW2, STP, STS, SX, SXS4, SX4, SX7, TX, TX2 TX26, TX4, UXU, VED, VED1, VET, VEX, VEX7, VMS4, VPR4, VSX VSX1, VX, VXU, VX4, VX7, WDA6, WD12, WJ, WJP, WKD6, WKT2 WKT4, WKT6, WMA3, WME2, WME4
					1	-	-	-	-----	-----	LTS
					1	-	-	-	4142770	-----	LAJ4
E-11-1	1		28400-ZE1-003ZA	STARTER ASSY., RECOIL *R8*.....BRIGHT RED	1	-	-	-	3463998	4142273	QT
		A	28400-ZE1-003ZF	*R280*.....POWER RED	1	-	-	-	4142274	-----	QT
	2		28410-ZE1-003ZA	CASE COMP., RECOIL STARTER *R8*.....BRIGHT RED	1	-	-	-	3463998	4142273	QT
		A	28410-ZE1-003ZF	*R280*.....POWER RED	1	-	-	-	4142274	-----	QT
E-12	4		19610-ZH7-V90ZA	COVER COMP., FAN *R8*.....BRIGHT RED	1	-	-	-	-----	-----	LTA
					1	-	-	-	-----	4142769	KRT, KRT4, KRT6
			19610-ZK7-V00ZA	*R8*.....BRIGHT RED	1	-	-	-	-----	4142769	AR, DKR, KR, KRA4, KRF4, KRS4
		A	19610-ZH7-V90ZB	*R280*.....POWER RED	1	-	-	-	4142770	-----	KRT, KRT4, KRT6
		A	19610-ZK7-V00ZD	*R280*.....POWER RED	1	-	-	-	4142770	-----	AR, DKR, KR, KRA4, KRF4, KRS4
E-17-1	9		17510-ZB4-000ZB	TANK COMP., FUEL *R8*.....BRIGHT RED	1	-	-	-	-----	4142273	LTR
		A	17510-ZB4-000ZH	*R280*.....POWER RED	1	-	-	-	4142274	-----	LTR

NOTE A:PART NO. CHANGE D:NEWLY PROVIDED E:PART NO.DELETION K:REQUIRED NO. CORRECTION L:APPLICATION SERIAL NO. CORRECTION  
T:APPLICATION CORRECTION Z:REMARKS CHANGE



# PARTS CATALOGUE NEWS

Honda Motor Co., Ltd. Service Division

## PARTS CATALOGUE - CORRECTED

Printed in Japan

CODE NO.	BOOKLET TYPE	13ZH70E9
	MICRO- FICHE	13ZH70EI/FI
PARTS CATALOGUE TITLE	GX120K1	
NEWS NO.	003	

Block No.	Ref. No.	Note	Part No.	Description	Reqd. QTY				Serial No.	Parts catalogue code
					(1)	GX120K1 (2)	(3)	(4)		
E-28	1		87522-ZH9-820	LABEL, CAUTION (THAI) .....	1	-	-	-	----- 4411054	QT
					-	(1)	-	-		
					-	-	1	-	-----	QIH1
	A		87522-ZH9-821	.....	1	-	-	-	4411055 -----	QT

NOTE A:PART NO. CHANGE D:NEWLY PROVIDED E:PART NO.DELETION K:REQUIRED NO. CORRECTION L:APPLICATION SERIAL NO. CORRECTION  
T:APPLICATION CORRECTION Z:REMARKS CHANGE

January 18, 2007



# PARTS CATALOGUE NEWS

Honda Motor Co., Ltd. Service Division

## PARTS CATALOGUE - CORRECTED

Printed in Japan

CODE NO.	BOOKLET TYPE	13ZH70E9
	MICRO-FICHE	13ZH70EI/FI
PARTS CATALOGUE NEWS	GX120K1	
NEWS NO.	004	

Block No.	Ref. No.	Note	Part No.	Description	Reqd. QTY				Serial No.	Parts catalogue code
					(1)	(2)	(3)	(4)		
E-28	1	T	87525-ZH7-000	EMBLEM, UPPER (INTERNAL) . . . . .	-	(1)	-	-	-----	U1, V1
		T	87525-ZH7-810	EMBLEM, UPPER (EXTERNAL) . . . . .	-	(1)	-	-	-----	U1, V1

NOTE A:PART NO. CHANGE D:NEWLY PROVIDED E:PART NO.DELETION K:REQUIRED NO. CORRECTION L:APPLICATION SERIAL NO. CORRECTION  
T:APPLICATION CORRECTION Z:REMARKS CHANGE



# PARTS CATALOGUE NEWS

Honda Motor Co., Ltd. Service Division

## PARTS CATALOGUE - CORRECTED

Printed in Japan

CODE NO.	BOOKLET TYPE	13ZH70E9
	MICRO-FICHE	13ZH70EI/FI
PARTS CATALOGUE NEWS	GX120K1	
NEWS NO.	005	

Block No.	Ref. No.	Note	Part No.	Description	Reqd. QTY	Serial No.	Parts catalogue code
					GX120K1 (1) (2) (3) (4)		

E-14-1 CARBURETOR (2)

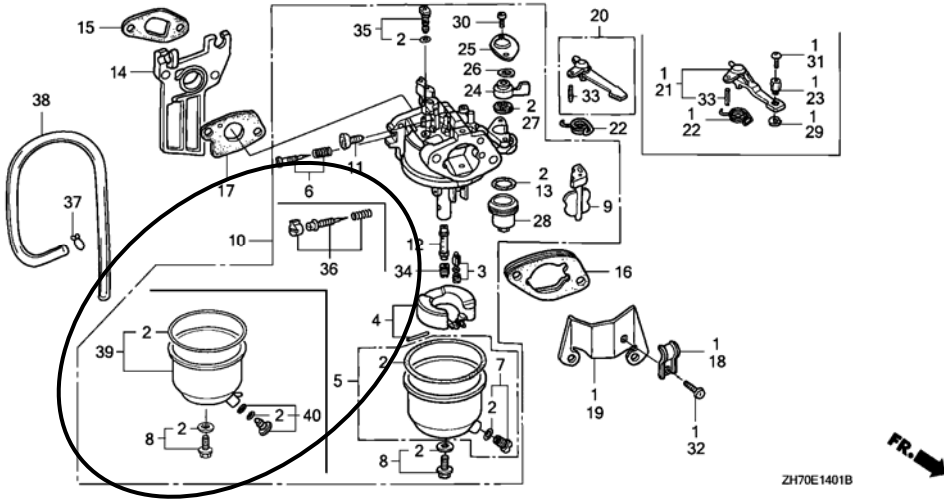

ZH70E1401B

E-14-1 5 E 16015-ZH7-A21 \*PARTS NO. DELETION

NOTE A:PART NO. CHANGE D:NEWLY PROVIDED E:PART NO.DELETION K:REQUIRED NO. CORRECTION L:APPLICATION SERIAL NO. CORRECTION  
T:APPLICATION CORRECTION Z:REMARKS CHANGE

PARTS CATALOGUE NEWS

BOOKNo. : 13ZH70E9

Block No.	Ref. No.	Note	Part No.	Description	Reqd. QTY				Serial No.	Parts catalogue code
					(1)	GX120K1 (2)	(3)	(4)		
	7	E	16024-ZH7-A20	*PARTS NO. DELETION						
	39	D	16015-ZH7-A21	CHAMBER SET, FLOAT .....	1	-	-	-	-----	VEK
	40	D	16024-ZH7-A20	SCREW SET, DRAIN .....	1	-	-	-	-----	VEK

NOTE A:PART NO. CHANGE D:NEWLY PROVIDED E:PART NO.DELETION K:REQUIRED NO. CORRECTION L:APPLICATION SERIAL NO. CORRECTION  
T:APPLICATION CORRECTION Z:REMARKS CHANGE



# PARTS CATALOGUE NEWS

Honda Motor Co., Ltd. Service Division

## PARTS CATALOGUE - CORRECTED

Printed in Japan

CODE NO.	BOOKLET TYPE	13ZH70E9
	MICRO-FICHE	13ZH70EI/FI
PARTS CATALOGUE NEWS	GX120K1	
NEWS NO.	006	

Block No.	Ref. No.	Note	Part No.	Description	Reqd. QTY				Serial No.	Parts catalogue code	
					(1)	(2)	(3)	(4)			
E-3	2	T	12000-ZF0-415	BARREL ASSY., CYLINDER .....	1	(1)	-	-	----- 4205163	AR, DKR, DS, HHQ4, HT2, H1, KR, KRA4, KRF4, KRS4, KRT, KRT4, KRT6, LAJ4, LD, LH, LHQ4, LJ, LJD2, LJS, LSJ, LSJ4, LTJ, LTK1, LTR, L1, QA, QA2, QB26, QD, QH, QHQ4, QH26, QJG2, QM, QMA4, QME4, QT, Q1, RD, RD4, RHC, RHQ4, R1, SAJ, SAJ4, SCJ, SD, SD16, SD4, SE, SH, SHQ4, SJ, SJC, SJD2, SKR, SM11, SSK1, SSK3, STP, STS, S1, VED, VEK, VET, WDA6, WD12, WJ, WJP, WMA3, WME4, WM1, W1	
			T	12000-ZF0-425	.....	1	(1)	-	-	4205164 -----	AR, DKR, DS, HHQ4, HT2, H1, KR, KRA4, KRF4, KRS4, KRT, KRT4, KRT6, LAJ4, LD, LH, LHQ4, LJ, LJD2, LJS, LSJ, LSJ4, LTJ, LTK1, LTR, L1, QA, QA2, QB26, QD, QH, QHQ4, QH26, QJG2, QM, QMA4, QME4, QT, Q1, RD, RD4, RHC, RHQ4, R1, SAJ, SAJ4, SCJ, SD, SD16, SD4, SE, SH, SHQ4, SJ, SJC, SJD2, SKR, SM11, SSK1, SSK3, STP, STS, S1, VED, VEK, VET, WDA6, WD12, WJ, WJP, WMA3, WME4, WM1, W1
								1	-	1	-

NOTE A:PART NO. CHANGE D:NEWLY PROVIDED E:PART NO.DELETION K:REQUIRED NO. CORRECTION L:APPLICATION SERIAL NO. CORRECTION  
T:APPLICATION CORRECTION Z:REMARKS CHANGE





# PARTS CATALOGUE NEWS

Honda Motor Co., Ltd.  
Customer Service Technology Development Division

## PARTS CATALOGUE - CORRECTED

Printed in Japan

CODE NO.	BOOKLET TYPE	13ZH70E9
	MICRO-FICHE	13ZH70EI/FI
PARTS CATALOGUE NEWS	GX120K1	
NEWS NO.	007	

Block No.	Ref. No.	Note	Part No.	Description	Reqd. QTY				Serial No.	Parts catalogue code
					(1)	GX120K1 (2)	(3)	(4)		
E-14-1	5	L	16015-ZE1-811	CHAMBER SET, FLOAT..... (FOR BE12A A)	-	(1)	-	-	-----	
				(FOR BE12A B)	-	(1)	-	-	-----	
				(FOR BE13A A)	-	(1)	-	-	-----	
				(CARBURETOR NO.)	1	-	1	1	-----	BE12A B DS, EN, ET, ETX, HH, HHQ4, HX4, LH, LHQ4, LJ, LTJ, LTR, LX, LX4 PH, PX, QEH, QH, QHQ4, QLL, QMA4, QMA8, QME4, QPU, QT, QX4, RH RHC, RHQ4, RX, RX4, SAJ, SCJ, SH, SHQ4, SJ, SJC, SKJ, SMA7 SMJ, SN, SSK1, SSK3, SSSX4, STP, STS, SX, SX4, TH, THVZ, TX4 UH, UIH, UX, VA, VED, VED1, VET, VEX, VH, VS, VS1, VSX, VSX1 VX, VX4, WJ, WJP, WJP1
				(CARBURETOR NO.)	1	-	-	-	-----	BE60B A HTF2, HX2, HX26, LX2, LX26, PX2, QAA2, QBU2, QH2, QH26, QMX2 QTC2, QX2, QX26, QXG2, QXS2, SAD2, SG24, SMM2, SSK2, TX2 TX26
				(CARBURETOR NO.)	1	-	-	-	-----	BE12A A HX, QX, QXG, QXS, TX
				(CARBURETOR NO.)	1	-	-	-	-----	BE60A A HXQ, QXQ
				(CARBURETOR NO.)	1	-	-	-	-----	BE60C A QA2, QA26, WKT2, WME2
				(CARBURETOR NO.)	1	-	-	-	-----	BE13A A QXC

NOTE A:PART NO. CHANGE D:NEWLY PROVIDED E:PART NO. DELETION K:REQUIRED NO. CORRECTION L:APPLICATION SERIAL NO. CORRECTION  
T:APPLICATION CORRECTION Z:REMARKS CHANGE

PARTS CATALOGUE NEWS

BOOKNo. : 13ZH70E9

Block No.	Ref. No.	Note	Part No.	Description	Reqd. QTY				Serial No.	Parts catalogue code
					(1)	GX120K1 (2)	(3)	(4)		
				(CARBURETOR NO.)	1	-	-	-	----- BE60F A QXC9	
					1	-	-	-	----- ----- VAX4	

NOTE A:PART NO. CHANGE D:NEWLY PROVIDED E:PART NO.DELETION K:REQUIRED NO. CORRECTION L:APPLICATION SERIAL NO. CORRECTION  
T:APPLICATION CORRECTION Z:REMARKS CHANGE



# PARTS CATALOGUE NEWS

Honda Motor Co., Ltd.  
Customer Service Technology Development Division

## PARTS CATALOGUE - CORRECTED

Printed in Japan

CODE NO.	BOOKLET TYPE	13ZH70E9
	MICRO-FICHE	13ZH70EI/FI
PARTS CATALOGUE NEWS	GX120K1	
NEWS NO.	008	

Block No.	Ref. No.	Note	Part No.	Description	Reqd. QTY				Serial No.	Parts catalogue code
					(1)	GX120K1 (2)	(3)	(4)		
E-17-3	4	E	17620-Z0T-814	*PART NO. DELETION						
		D	17620-Z0T-305	CAP COMP., FUEL FILLER (CHROME PLATED) (TOYOSHA)	1	-	-	-	-----	LTS

NOTE A:PART NO. CHANGE D:NEWLY PROVIDED E:PART NO.DELETION K:REQUIRED NO. CORRECTION L:APPLICATION SERIAL NO. CORRECTION  
T:APPLICATION CORRECTION Z:REMARKS CHANGE

May 17, 2015



# PARTS CATALOGUE NEWS

Service Technology Department, Power Products Operations  
 Service Division, Honda Motor Co., Ltd.

## PARTS CATALOGUE - CORRECTED

Printed in Japan

CODE NO.	13ZH70E9
PARTS CATALOGUE NEWS	GX120K1
NEWS NO.	009

Block No.	Ref. No.	Note	Part No.	Description	Reqd. QTY				Serial No.	Parts catalogue code
					(1)	GX120K1 (2)	(3)	(4)		
E-17	12	T	17510-ZH7-A20ZD	TANK COMP., FUEL *NH31*.....MCKINLEY WHITE	1	-	-	-	-----	SKJ, SMJ, VEK

NOTE A:PART NO. CHANGE D:NEWLY PROVIDED E:PART NO. DELETION K:REQUIRED NO. CORRECTION L:APPLICATION SERIAL NO. CORRECTION  
 M:PART DESCRIPTION CORRECTION T:APPLICATION CORRECTION Z:REMARKS CHANGE



# PARTS CATALOGUE NEWS

Service Technology Department, Power Products Operations  
 Service Division, Honda Motor Co., Ltd.

## PARTS CATALOGUE - CORRECTED

Printed in Japan

CODE NO.	13ZH70E9
PARTS CATALOGUE NEWS	GX120K1
NEWS NO.	010

Block No.	Ref. No.	Note	Part No.	Description	Reqd. QTY				Serial No.	Parts catalogue code
					(1)	GX120K1 (2)	(3)	(4)		
E-15-3	5	M	17230-ZE1-841	COVER, AIR CLEANER (CYCLONE)...	1	-	-	-	-----	QXC, QXC9
					-	(1)	-	-		

NOTE A:PART NO. CHANGE D:NEWLY PROVIDED E:PART NO. DELETION K:REQUIRED NO. CORRECTION L:APPLICATION SERIAL NO. CORRECTION  
 M:PART DESCRIPTION CORRECTION T:APPLICATION CORRECTION Z:REMARKS CHANGE



# PARTS CATALOGUE NEWS

Service Technology Department, Power Products Operations  
Service Division, Honda Motor Co., Ltd.

## PARTS CATALOGUE - CORRECTED

Printed in Japan

CODE NO.	13ZH70E9
PARTS CATALOGUE NEWS	GX120K1
NEWS NO.	011

Block No.	Ref. No.	Note	Part No.	Description	Reqd. QTY	Serial No.	Parts catalogue code
					(1) GX120K1 (2) (3) (4)		

E-16 MUFFLER (1)

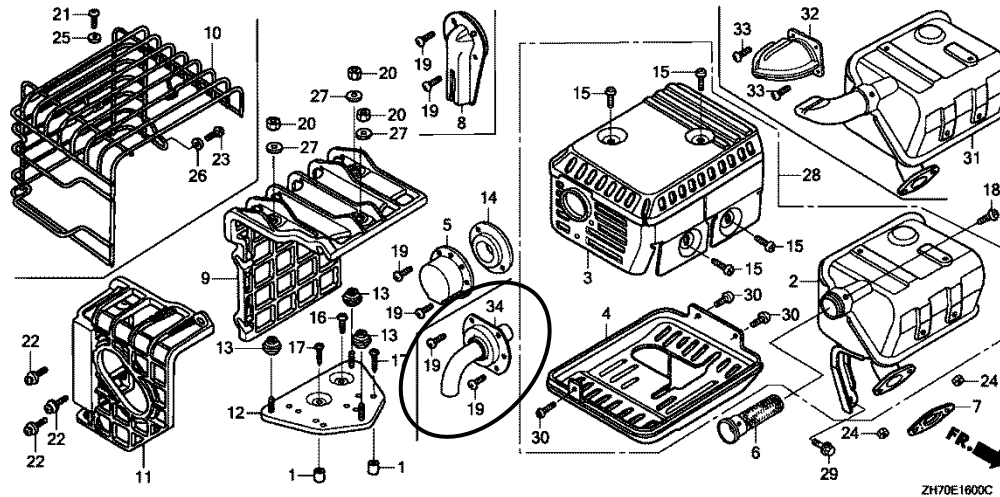

E-16	5	E	18340-ZH7-U20	*PARTS NO. DELETION			
	34	D	18340-ZH7-U20	DEFLECTOR COMP.....	1	- - - -	QJG2, QXG2

NOTE A:PART NO. CHANGE D:NEWLY PROVIDED E:PART NO. DELETION K:REQUIRED NO. CORRECTION L:APPLICATION SERIAL NO. CORRECTION  
M:PART DESCRIPTION CORRECTION T:APPLICATION CORRECTION Z:REMARKS CHANGE

PARTS CATALOGUE NEWS

BOOKNo. :13ZH70E9

Block No.	Ref. No.	Note	Part No.	Description	Reqd. QTY				Serial No.	Parts catalogue code
					(1)	(2)	(3)	(4)		
					1	-	-	-	2077062	----- QXG

E-40 ENGINE STOP SWITCH (OTHER PARTS)

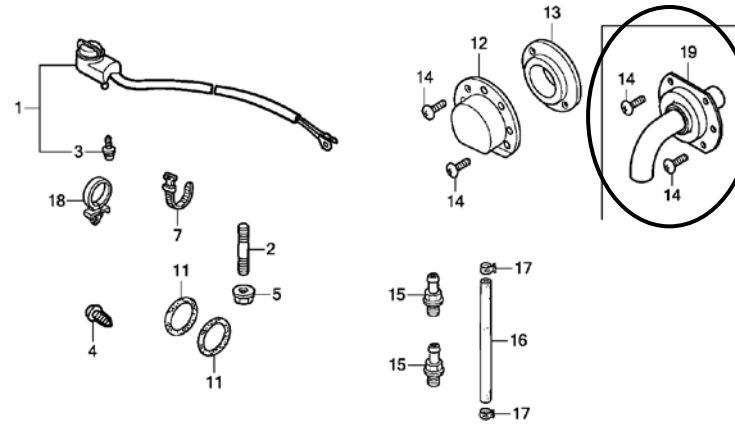

ZH70E4000C

E-40	12	E	18340-ZH7-U20	*PARTS NO. DELETION						
	19	D	18340-ZH7-U20	DEFLECTOR COMP.....	1	-	-	-	-----	LTS

NOTE A:PART NO. CHANGE D:NEWLY PROVIDED E:PART NO. DELETION K:REQUIRED NO. CORRECTION L:APPLICATION SERIAL NO. CORRECTION  
M:PART DESCRIPTION CORRECTION T:APPLICATION CORRECTION Z:REMARKS CHANGE



# PARTS CATALOGUE NEWS

Service Technology Department, Power Products Operations  
Service Division, Honda Motor Co., Ltd.

## PARTS CATALOGUE - CORRECTED

Printed in Japan

CODE NO.	13ZH70E9
PARTS CATALOGUE NEWS	GX120K1
NEWS NO.	012

Block No.	Ref. No.	Note	Part No.	Description	Reqd. QTY				Serial No.	Parts catalogue code				
					(1)	(2)	(3)	(4)						
E-22	7	T	16561-ZE0-020	SPRING, GOVERNOR. ....	1	1	1	1	-----	AR, DKR, DS, H1, HH, HHQ4, HT2, HTF2, HX, HX2, HX26, HX4, HXQ HXU, KRA4, KRF4, KRS4, KRT4, KRT6, LAJ4, LD, LD4, LDB1, LDB3 LE, LEH4, LHQ4, LJD2, LJS, LJT, LSJ, LSJ4, LTA, LW2, LX, LX2 LX26, LX4, LXU, PH, PM, PM2, PX, PX2, Q1, QA, QA2, QA26, QAA2 QB26, QBU2, QD, QE, QEH, QH2, QH26, QHQ4, QIH1, QJG2, QLL, QM QMA4, QMA8, QME4, QMH, QMX2, QPU, QSJ, QT, QTC2, QWA4, QX QX2, QX26, QX4, QX7, QXC, QXC9, QXG, QXG2, QXQ, QXS, QXS2 QXU, RD, RD4, RH, RHC, RHQ4, RX, RX4, SAD2, SAJ4, SCJ, SD16 SD4, SDB1, SDB3, SE, SG24, SH, SHQ4, SJC, SJD2, SKJ, SM12 SM14, SMA7, SMW2, SN, SSK1, SSK2, SSK2, SSK4, STP, STS, SW2 SWX2, SWX4, SX, SX4, SX7, SXS4, TH, THVZ, TX, TX2, TX26, TX4 U1, UH, UIH, UX, UXU, V1, VA, VEE1, VET, VH, VX, VX4, VX7, W1 WD12, WDA6, WDJ, WIH1, WJ1, WJP, WJP1, WKD6, WKT2, WKT4 WKT6, WM1, WMA3, WME2, WME4				
							1	-	-	-	-----	3422682	VXU	
			D	16561-ZE0-030	.....	1	1	-	-	-	-----	-----	KR, KRT, L1, LH, LJ, LJC, LTJ, LTK1, LTR, LTS, QH, R1, S1, SAJ SD, SJ, SJC1, SJC5, SKR, SM11, SMJ, SSK3, WJ	
E-22-1	3	T	16561-ZE0-020	SPRING, GOVERNOR. ....	1	-	-	-	-----	-----	EN, ET, ETX, VAX4, VED1, VED6, VEX, VEX7, VMS4, VMT, VPR4, VS VS1			
									1	-	-	-	3422683	VXU
			D	16561-ZE0-030	.....	1	-	-	-	-----	-----	VED, VSX, VSX1		
E-31	3	E	56850-767-000	*PARTS NO. DELETION										
			D	56850-767-010	TANK ASSY., OIL. ....	1	-	-	-	-----	-----	SSK3		

NOTE A:PART NO. CHANGE D:NEWLY PROVIDED E:PART NO. DELETION K:REQUIRED NO. CORRECTION L:APPLICATION SERIAL NO. CORRECTION  
M:PART DESCRIPTION CORRECTION T:APPLICATION CORRECTION Z:REMARKS CHANGE



# HONDA PARTS CATALOGUE NEWS

Service Information Department, Power Product Operations  
 Service Division, Honda Motor Co., Ltd.

## PARTS CATALOGUE - CORRECTED

CODE NO.	13ZH70E9
PARTS CATALOGUE NEWS	GX120K1
NEWS NO.	013

Block No.	Ref. No.	Note	Part No.	Description	Reqd. QTY				Serial No.	Parts catalogue code	
					(1)	(2)	(3)	(4)			
E-9	21	T	12209-ZH8-003	SEAL, VALVE STEM.....	1	1	-	-	3993726	AR, DKR, DS, H1, HHQ4, HTF2, HX, HX2, HX26, HX4, HXU, KR, KRA4, KRT, KRT4, KRT6, LAJ4, LD, LH, LHQ4, LJ, LJC, LJD2, LJS, LSJ, LSJ4, LTJ, LTK1, LTR, LX, LX2, LX26, LX4, LXU, PH, PM, PX, PX2, Q1, QA, QA2, QB26, QD, QH, QH26, QHQ4, QJG2, QLL, QM, QMA4, QMA8, QME4, QMX2, QT, QTC2, QWA4, QX, QX2, QX26, QX4, QXC9, QXG2, QXS2, QXU, R1, RD, RD4, RHC, RHQ4, RX, RX4, SAJ, SAJ4, SCJ, SD, SD16, SD4, SE, SG24, SH, SHQ4, SJ, SJC1, SJC5, SKJ, SM11, SMA7, SMJ, SMW2, SSK3, SSS2, SSS4, STP, STS, SWX2, SWX4, SX, SX4, SXS4, TH, TX, TX2, TX26, TX4, UH, UX, UXU, VED, VED1, VED6, VEE1, VET, VEX, VMS4, VMT, VPR4, VSX, VSX1, VX, VX4, VXU, WD12, WDA6, WJ, WJP, WJP1, WKD6, WKT2, WKT4, WM1, WMA3, WME2, WME4	
					1	-	1	-	-----	-----	HT2, KRF4, KRS4, LTS, QIH1, QX7, SJD2, SM12, SM14, SX7, VEK, VEX7, VX7, WIH1, WKT6
E-17	14	T	17620-ZE2-W00	CAP COMP., FUEL FILLER (CHROME PLATED)	1	-	1	1	-----	-----	LDB1, LDB3, SDB1, SDB3, THVZ, UIH, VEE1
					1	-	-	-	-----	2421922	DS, EN, ET, ETX, HH, HX, HX2, HXQ, LD, LE, LH, LJ, LTJ, LW2, LX, LX2, PH, PM, PM2, PX, QA, QA2, QD, QE, QEH, QH, QH2, QLL, QM, QPU, QSJ, QT, QX, QX2, QXC, QXG, QXG2, QXQ, QXS, QXS2, RD, RH, RX, SCJ, SD, SE, SH, SJ, SKJ, SMJ, SN, STS, SW2, SX, TH, TX, TX2, UH, UX, VA, VED, VED1, VET, VEX, VH, VS, VS1, VSX, VSX1, VX, WJ
					1	-	-	-	2533058	-----	QT
					-	(1)	-	-	-----	2421922	

NOTE A:PART NO. CHANGE D:NEWLY PROVIDED E:PART NO. DELETION K:REQUIRED NO. CORRECTION L:APPLICATION SERIAL NO. CORRECTION  
 M:PART DESCRIPTION CORRECTION T:APPLICATION CORRECTION Z:REMARKS CHANGE

PARTS CATALOGUE NEWS

BOOKNo. :13ZH70E9

Block No.	Ref. No.	Note	Part No.	Description	Reqd. QTY				Serial No.	Parts catalogue code
					(1)	GX120K1 (2)	(3)	(4)		
	43	T	17620-Z0T-814	CAP COMP., FUEL FILLER (CHROME PLATED) (TOYOSHA)	1	-	-	-	4203083	----- DS, HHQ4, HT2, HTF2, HX, HX2, HX26, HX4, HXU, LAJ4, LD, LHQ4 LJD2, LJS, LSJ, LSJ4, LX, LX2, LX4, LXU, PX, PX2, QA, QA2, QD QH26, QHQ4, QJG2, QLL, QM, QMA4, QMA8, QME4, QMX2, QWA4, QX QX2, QX26, QX4, QX7, QXC9, QXS2, QXU, RD, RD4, RHQ4, RX, RX4 SAJ4, SCJ, SD16, SD4, SE, SG24, SH, SHQ4, SJD2, SM12, SM14 SMA7, SMW2, SSK1, SSSX2, SSSX4, STP, STS, SWX2, SWX4, SX, SX4 SX7, SXS4, TX, TX2, TX26, TX4, UXU, VED1, VED6, VET, VEX VEX7, VMS4, VX, VX4, VX7, VXU, WD12, WDA6, WJP, WKD6, WKT2 WKT4, WKT6, WMA3, WME2, WME4
					1	-	-	-	4203083	4203082 LH, LJ, LJC, LTJ, LTK1, QH, SAJ, SD, SJ, SJC1, SJC5, SKR, SM11 SMJ, SSK3, VED, VEK, VSX, VSX1, WJ
					-	(1)	-	-	4203083	----- H1, L1, Q1, R1
					-	-	1	-	-----	----- QIH1, WIH1
	44	T	17631-Z0T-812	PACKING, FUEL FILLER CAP (39X62X3) (TOYOSHA)	1	-	-	-	4203083	----- DS, HHQ4, HT2, HTF2, HX, HX2, HX26, HX4, HXU, LAJ4, LD, LH LHQ4, LJ, LJC, LJD2, LJS, LSJ, LSJ4, LTJ, LTK1, LX, LX2, LX4 LXU, PX, PX2, QA, QA2, QD, QH, QH26, QHQ4, QJG2, QLL, QM, QMA4 QMA8, QME4, QMX2, QWA4, QX, QX2, QX26, QX4, QX7, QXC9, QXS2 QXU, RD, RD4, RHQ4, RX, RX4, SAJ, SAJ4, SCJ, SD, SD16, SD4, SE SG24, SH, SHQ4, SJ, SJC1, SJC5, SJD2, SKR, SM11, SM12, SM14 SMA7, SMJ, SMW2, SSK1, SSK3, SSSX2, SSSX4, STP, STS, SWX2 SWX4, SX, SX4, SX7, SXS4, TX, TX2, TX26, TX4, UXU, VED, VED1 VED6, VEK, VET, VEX, VEX7, VMS4, VSX, VSX1, VX, VX4, VX7, VXU WD12, WDA6, WJ, WJP, WKD6, WKT2, WKT4, WKT6, WMA3, WME2 WME4
					-	(1)	-	-	4203083	----- H1, L1, Q1, R1
					-	-	1	-	-----	----- QIH1, WIH1

NOTE A:PART NO. CHANGE D:NEWLY PROVIDED E:PART NO. DELETION K:REQUIRED NO. CORRECTION L:APPLICATION SERIAL NO. CORRECTION  
M:PART DESCRIPTION CORRECTION T:APPLICATION CORRECTION Z:REMARKS CHANGE

# HONDA PARTS CATALOGUE NEWS

## PARTS CATALOGUE - CORRECTED

CODE NO.	13ZH70E9
PARTS CATALOGUE NEWS	GX120K1
NEWS NO.	014

Block No.	Ref. No.	Note	Part No.	Description	Reqd. QTY				Serial No.	Parts catalogue code
					(1)	GX120K1 (2)	(3)	(4)		
E-17	43	L	17620-Z0T-814	CAP COMP., FUEL FILLER (CHROME PLATED) (TOYOSHA)	1	-	-	-	4203083 -----	DS, HHQ4, HT2, HTF2, HX, HX2, HX26, HX4, HXU, LAJ4, LD, LH, LHQ4, LJ, LJC, LJD2, LJS, LSJ, LSJ4, LTJ, LTK1, LX, LX2, LX4, LXU, PX, PX2, QA, QA2, QD, QH, QH26, QHQ4, QJG2, QLL, QM, QMA4, QMA8, QME4, QMX2, QWA4, QX, QX2, QX26, QX4, QX7, QXC9, QXS2, QXU, RD, RD4, RHQ4, RX, RX4, SAJ, SAJ4, SCJ, SD, SD16, SD4, SE, SG24, SH, SHQ4, SJ, SJC1, SJC5, SJD2, SKR, SM11, SM12, SM14, SMA7, SMJ, SMW2, SSK1, SSK3, SSS2, SSS4, STP, STS, SWX2, SWX4, SX, SX4, SX7, SXS4, TX, TX2, TX26, TX4, UXU, VED, VED1, VED6, VEK, VET, VEX, VEX7, VMS4, VSX, VSX1, VX, VX4, VX7, VXU, WD12, WDA6, WJ, WJP, WKD6, WKT2, WKT4, WKT6, WMA3, WME2, WME4
					-	(1)	-	-	4203083 -----	H1, L1, Q1, R1
					-	-	1	-	-----	QIH1, WIH1

NOTE A:PART NO. CHANGE D:NEWLY PROVIDED E:PART NO. DELETION K:REQUIRED NO. CORRECTION L:APPLICATION SERIAL NO. CORRECTION  
M:PART DESCRIPTION CORRECTION T:APPLICATION CORRECTION Z:REMARKS CHANGE