

Forward vibratory plates – asphalt F70A Spare Parts List

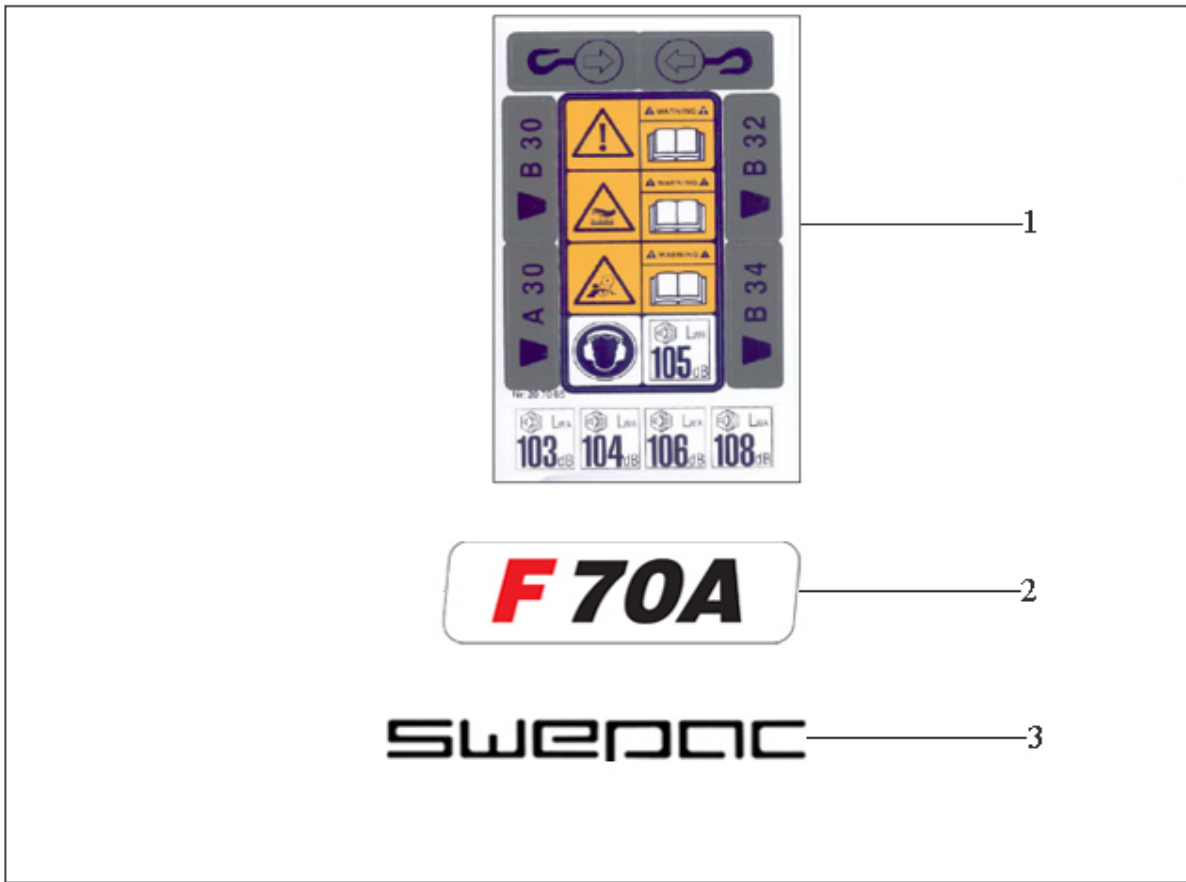

TABLE OF CONTENT

1. Labels	5
2. Engine	6
2.1. B Centrifugal clutch	7
2.1.1. Centrifugal clutch, parts	8
2.1. A Centrifugal clutch	9
2.1.1. Centrifugal clutch, parts for 100897	10
2.1.1. Centrifugal clutch	11
2.1.1. Centrifugal clutch, parts for 100821	12
2.2. Mounting parts	13
2.3. Engine, parts	14
2.3. Engine cpl. from 2019 March	15
2.4. Oil drain hose, parts	16
2.5. Hand start	17
2.5.1. Hand start cpl.	18
2.5.5. Hand start, parts	19
2.6. Fuel tank black	20
2.7. Silencer	21
2.7.1. Silencer cpl.	22
2.7.7. Silencer, parts	23
3. Chassis	24
3.1. Chassi, parts	25
3.2. Belt tensioner, parts	26
3.2. Belt tensioner cpl.	27
3.3. C Belt guard red, plastic	28
4. A Vibrations unit, grease lubricate	29
4.1. Vibrations unit	30
4.1. Vibrations unit, parts	31
4.2. V-belt	32
4. B Vibrations unit, oil lubricate	33
4.1. Vibration unit, parts	34
4.2. V-belt	35
5. Base plate with bracket for wheels	36
6. Transport wheel	37
7. Handle	38
7.1. B Low vibrated handle	39
7.1.1. Handel, cpl	40
7.1.1. Handle, parts	41
7.1. A Handle	42
7.1.1. Handel, parts	43
8. Sprinkler system	44
9. Vulkollan plate (Accessories)	45
9.1. Vulkollan plate, parts	46
9.1. Vulkollan plate cpl.	47
10. Service kit	48
10.1. Service kit	51

10.2. Service kit 54

1. LABELS



Pos	Part.No	Label	No
1	207065	DECAL	1
2	207092	DECAL F70	2
3	305032	DECAL	1

2. ENGINE

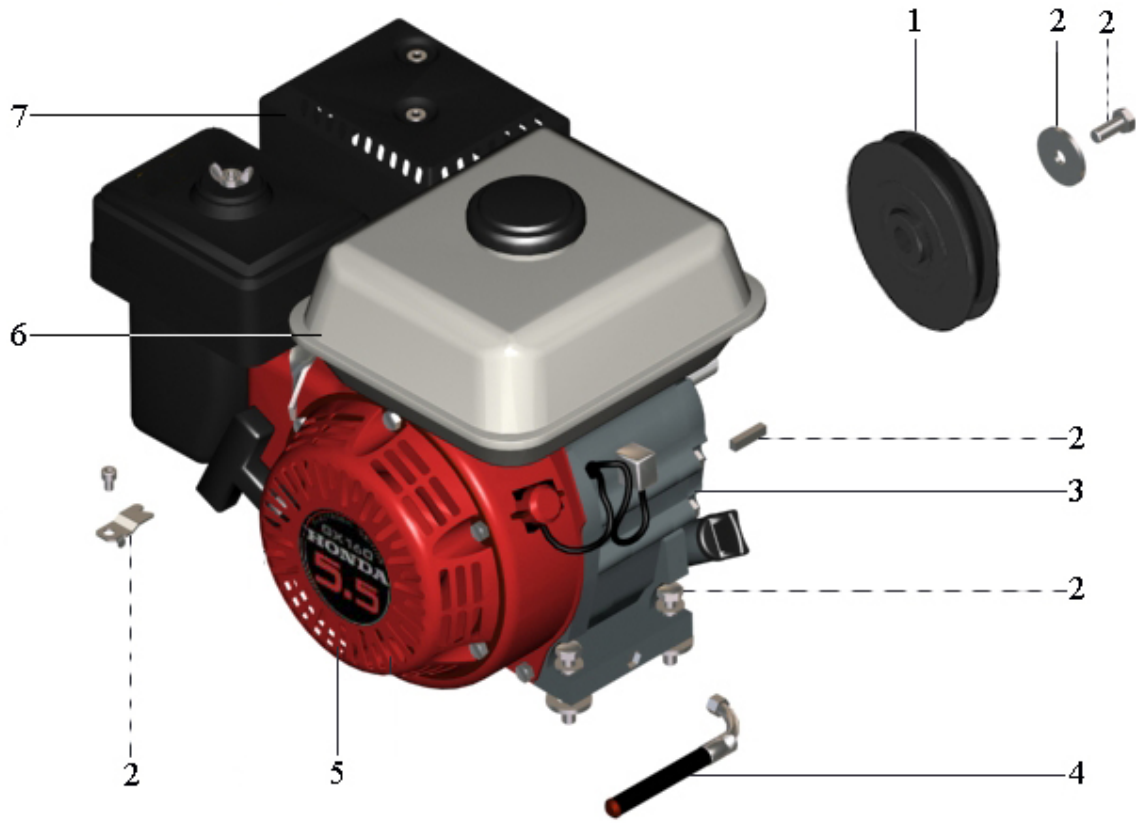

Pos	Label
1	B Centrifugal clutch
1	A Centrifugal clutch
2	Mounting parts
3	Engine,parts
3	Engine cpl. from 2019 March
4	Oil drain hose, parts
5	Hand start
6	Fuel tank black
7	Silencer

2.1. B CENTRIFUGAL CLUTCH

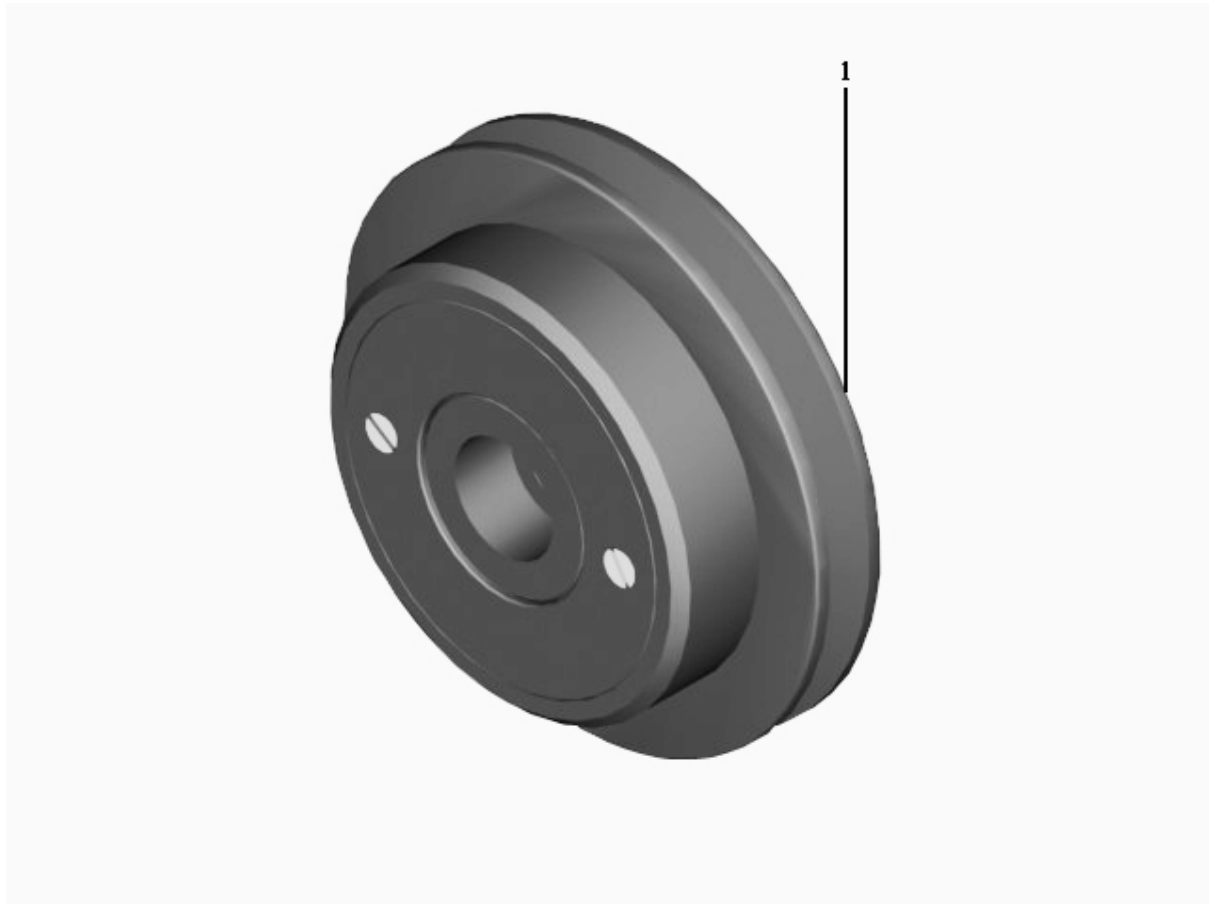

Pos	Label
1	Centrifugal clutch, parts

2.1.1. CENTRIFUGAL CLUTCH, PARTS

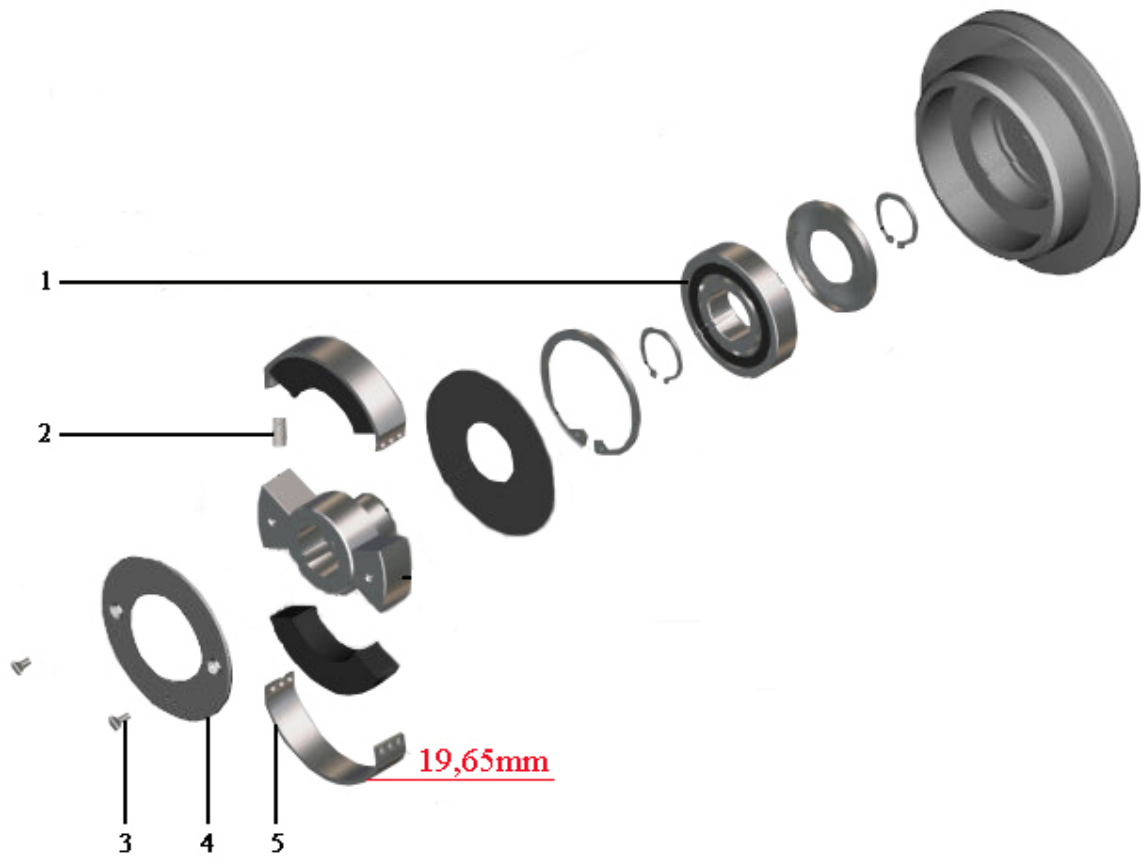

Pos	Part.No	Label	No
1	100820	BALL BEARING 6008.2Z	1
2	100812	SPRING	4
3	100120	BOLT / MF6S 4x12 10.9	2
4	100817	END CAP	1
5	100811	CLUTCH LINING	2

2.1. A CENTRIFUGAL CLUTCH



Pos	Label
1	Centrifugal clutch, parts for 100897
1	Centrifugal clutch
1	Centrifugal clutch, parts for 100821

2.1.1. CENTRIFUGAL CLUTCH, PARTS FOR 100897

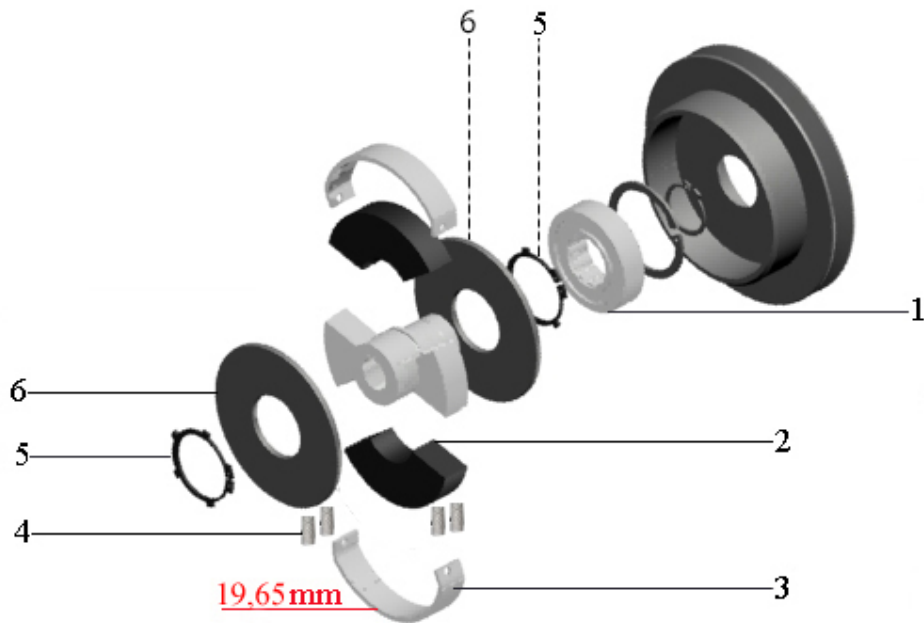

Pos	Part.No	Label	No
1	100830	BALL BEARING 6006 2RS	1
2	100864	WEIGHT	2
3	100811	CLUTCH LINING	2
4	100898	SPRING	4
5	100431	CIRCLIP / A40x1,75K	2
6	100866	COVER	2

2.1.1. CENTRIFUGAL CLUTCH



Pos	Part.No	Label	No
1	100897	CLUTCH	1

2.1.1. CENTRIFUGAL CLUTCH, PARTS FOR 100821

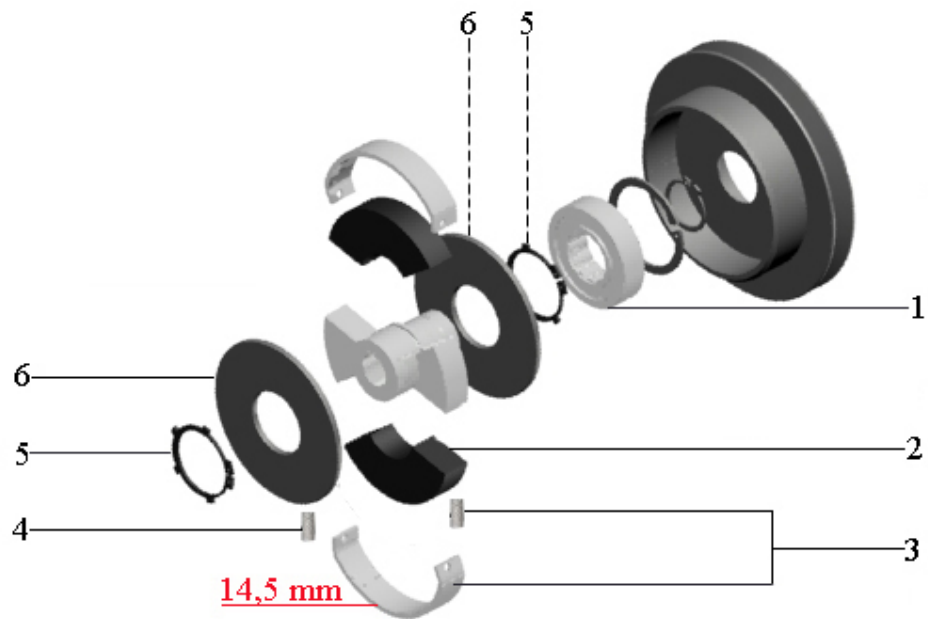

Pos	Part.No	Label	No
1	100830	BALL BEARING 6006 2RS	1
2	100865	WEIGHT	2
3	1008104	CLUTCH LINING KIT	1
4	100827	SPRING	2
5	100431	CIRCLIP / A40x1,75K	2
6	100866	COVER	2

2.2. MOUNTING PARTS

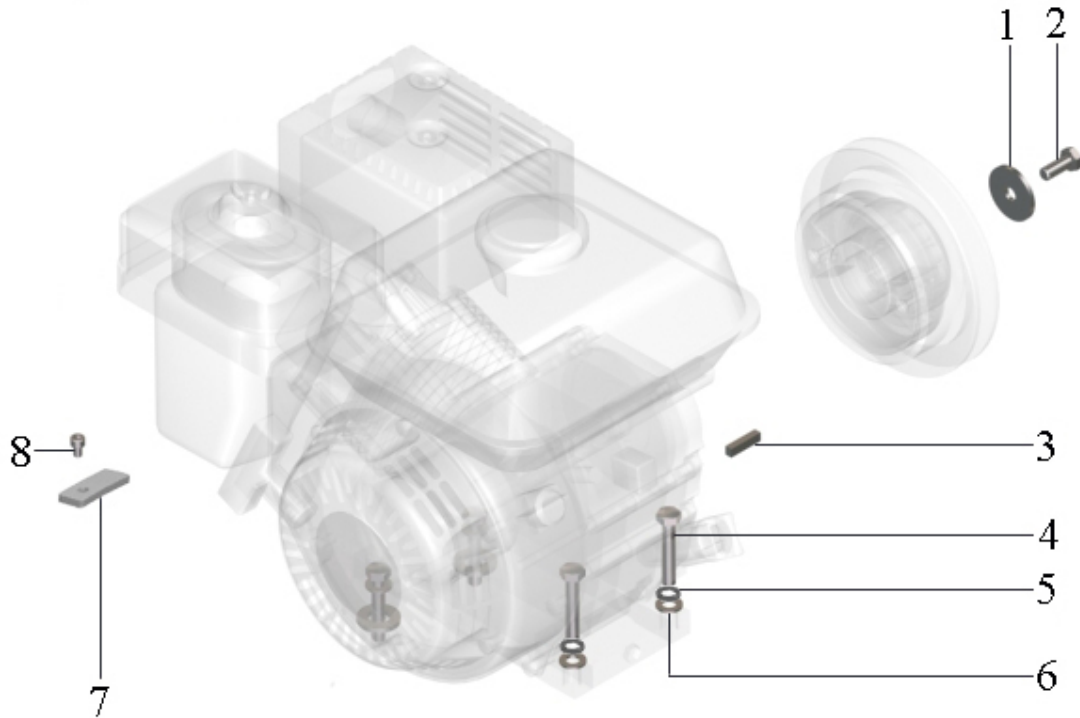

Pos	Part.No	Label	No
1	100356	WASHER / HS 8,4x29x2	1
2	1001107	BOLT / M6SF 8x20 8.8 FZB	1
3	100430	FLAT KEY / TK 5x5x30 H9	1
4	100150	BOLT / M6S 8x35 8.8 fzb	4
5	100326	WASHER / HS 8	4
6	100301	WASHER / BRB 8,4x16 HB200 fzb	4
7	202140	STOPPER	1
8	1001146	BOLT/ MRT M5x16 fzb	1

2.3. ENGINE,PARTS

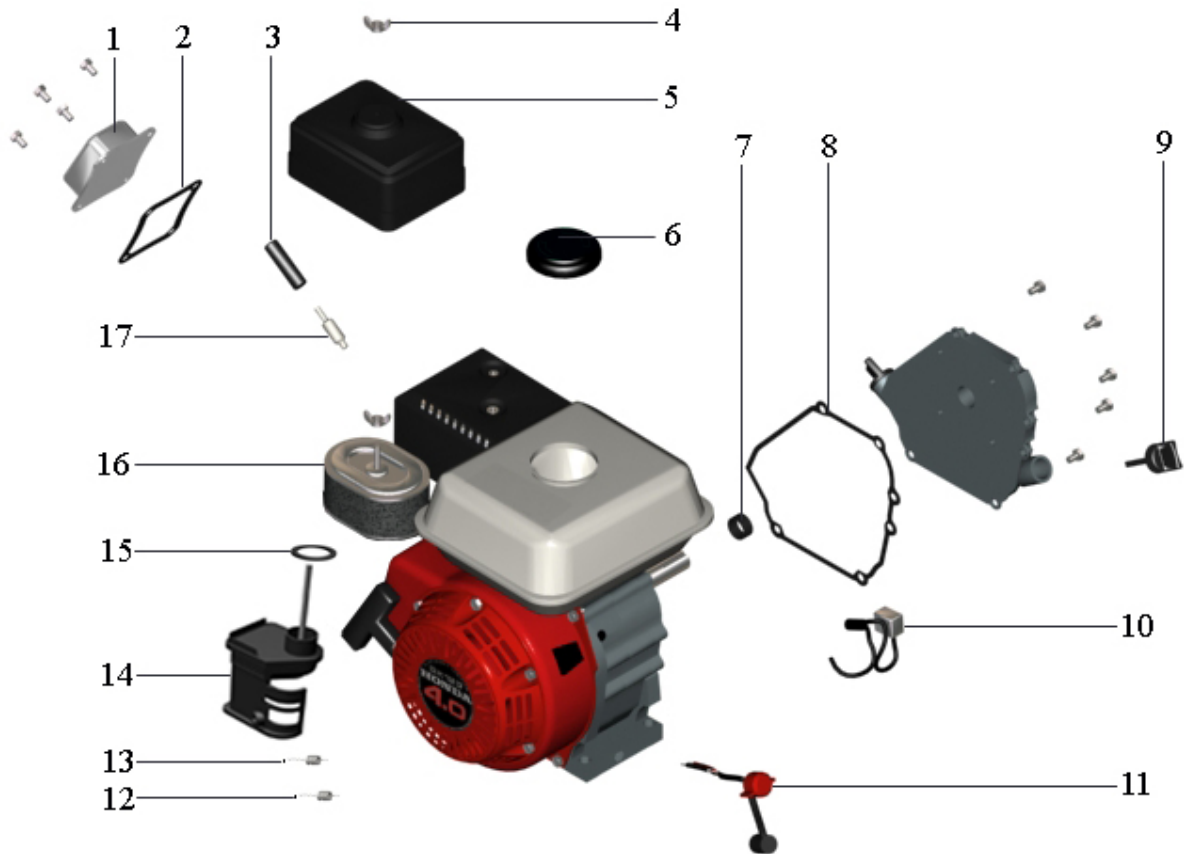

Pos	Part.No	Label	No
1	101857	BONNET ASSY, HEAD	1
2	101281	GASKET, BONNET	1
3	101277	BOOT-SPARK PLUG	1
4	101299	WING NUT, AIR FILTER	2
5	101298	COVER-AIR CLEANER	1
6	101275	CAP-FUEL TANK	1
7	101290	RADIAL SEAL	1
8	101272	SEAL, CRANKCASE	1
9	101280	DIP STICK	1
10	101760	CONTROL, OIL ALERT	1
11	101276	CIRCUIT BREAKER	1
12	101837	SPRING THROTTLE RETURN	1
13	101835	SPRING REGULATOR	1
14	101864	FILTER BRACKET	1
15	101832	SEAL	1
16	101210	AIR FILTER 70mm HIGH	1
16	101209	AIR FILTER	1
17	101278	SPARK-PLUG	1

2.3. ENGINE CPL. FROM 2019 MARCH

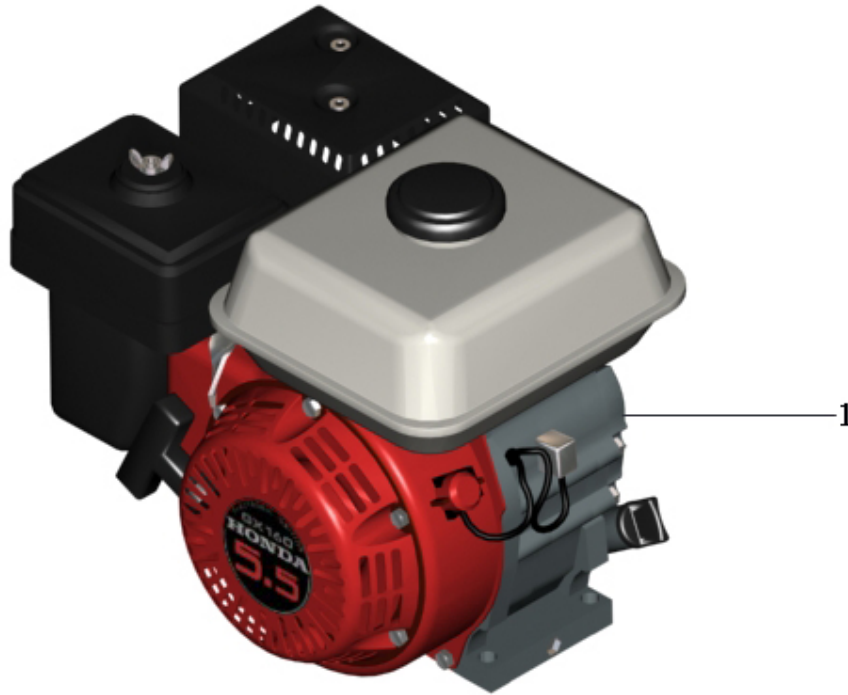

Pos	Part.No	Label	No
1	1018111	PETROL ENGINE / HONDA GX 120UT3 SXS4 SD	1

2.4. OIL DRAIN HOSE, PARTS

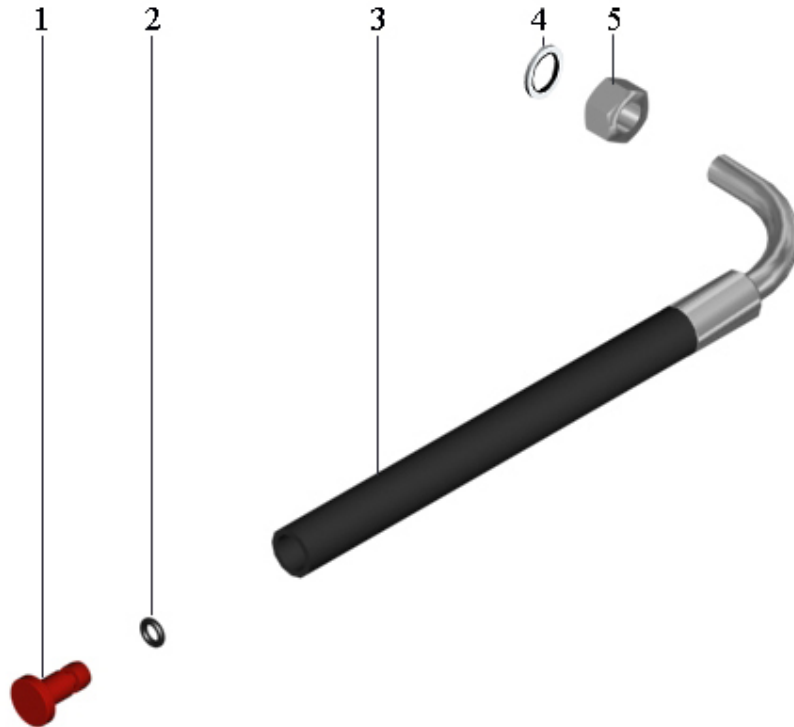

Pos	Part.No	Label	No
1	202066	PLUG	1
2	100609	O-RING / 6,3x2,4 NBR 70	1
3	202110	BLEEDER PIPE	1
4	101073	RUBBER/STEEL WASHER R1/8	1
5	100213	NUT / ML6M 10x1,25 GB4 fzb	1

2.5. HAND START

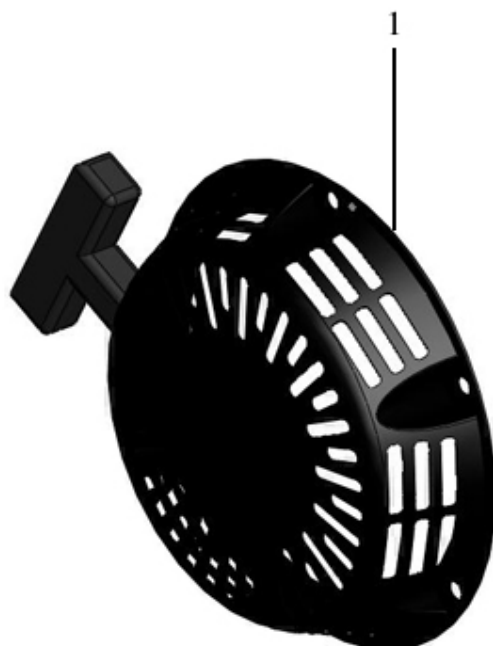

Pos	Label
1	Hand start cpl.
5	Hand start, parts

2.5.1. HAND START CPL.

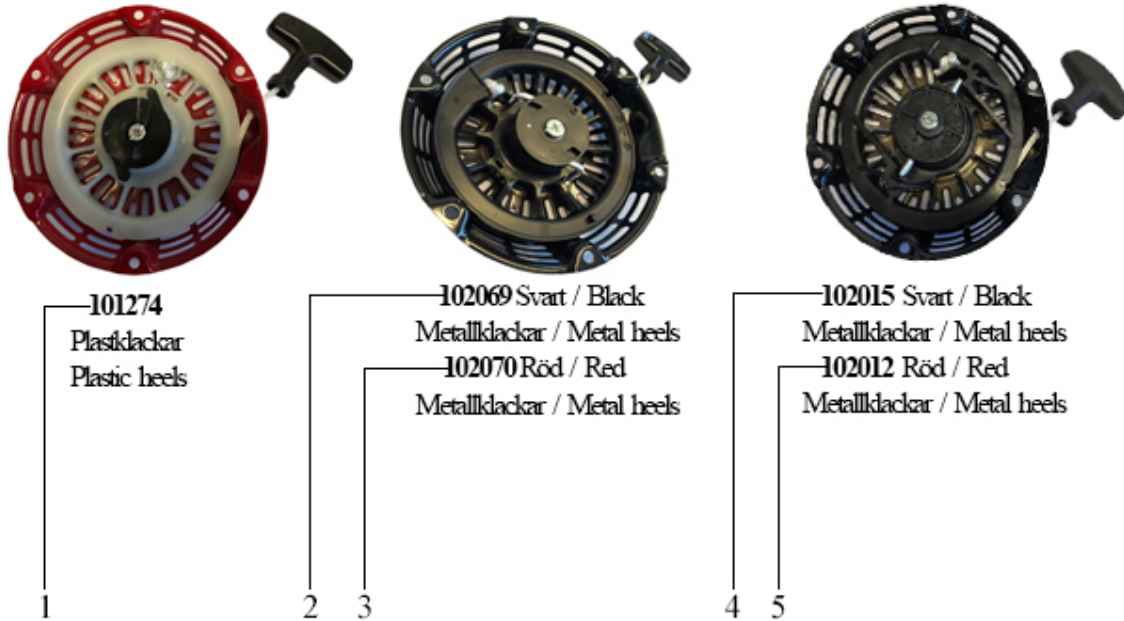

Pos	Part.No	Label	No
1	101274	HAND START	1
2	102069	HAND START / METAL HEELS / BLACK	1
3	102070	HAND START / METAL HEELS / RED	1
4	102015	HAND START / METAL HEELS / BLACK	1
5	102012	HAND START / METAL HEELS / RED	1

2.5.5. HAND START, PARTS

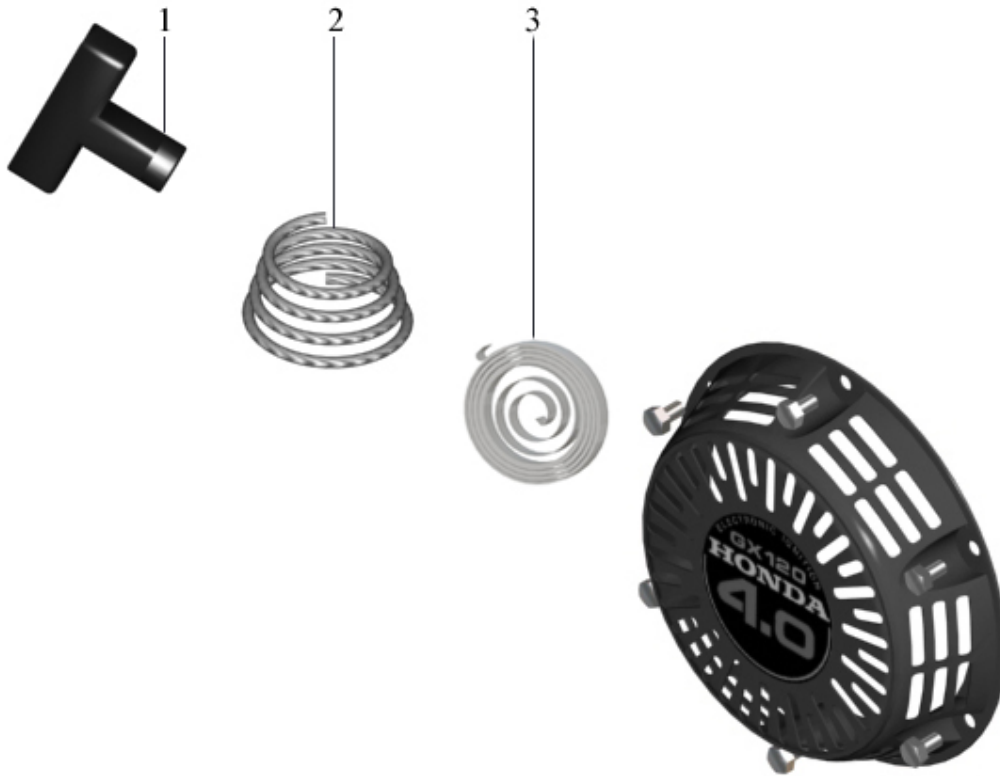

Pos	Part.No	Label	No
1	101279	KNOB, HAND START	1
2	101221	RECOIL STARTER WIRE	1
3	101822	RETURN SPRING HAND START	1

2.6. FUEL TANK BLACK

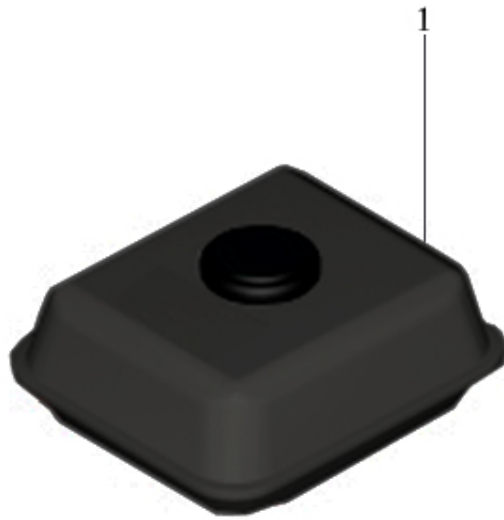

Pos	Part.No	Label	No
1	102022	FUEL TANK BLACK	1

2.7. SILENCER

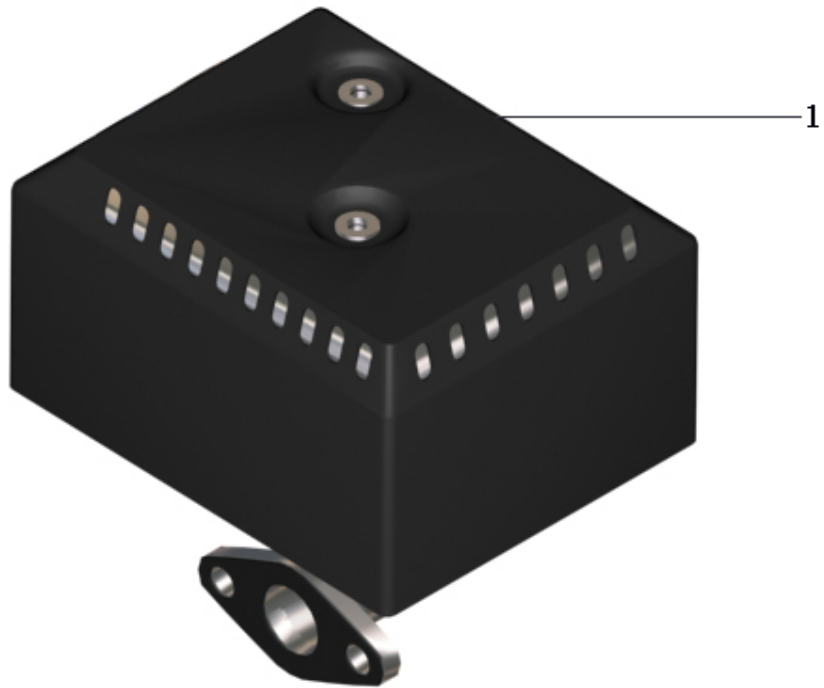

Pos	Label
1	Silencer cpl.
7	Silencer, parts

2.7.1. SILENCER CPL.

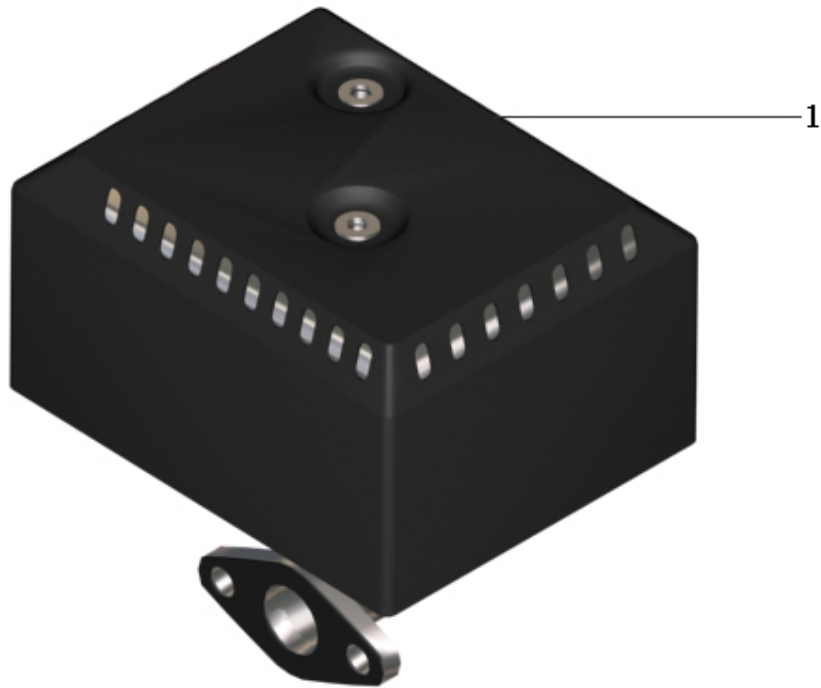

Pos	Part.No	Label	No
1	101284	MUFFLER	1

2.7.7. SILENCER, PARTS

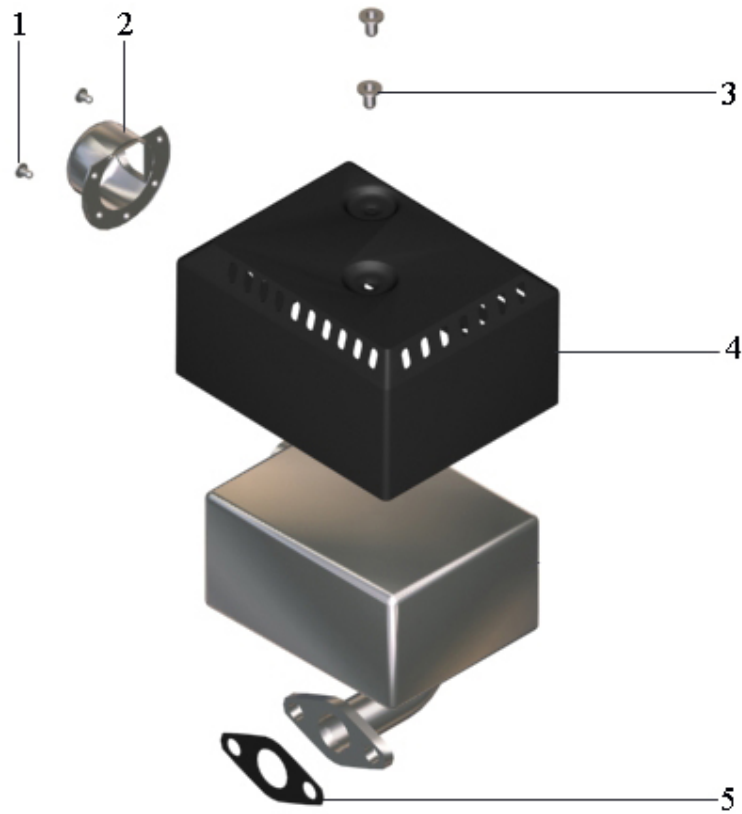

Pos	Part.No	Label	No
1	100316	RIVET / 3,2x11x22	2
2	101270	DEFLECTOR	1
3	100185	BOLT / RXS 5x8	2
4	101285	COVER	1
5	101282	SEAL, SILENCER	1

3. CHASSIS

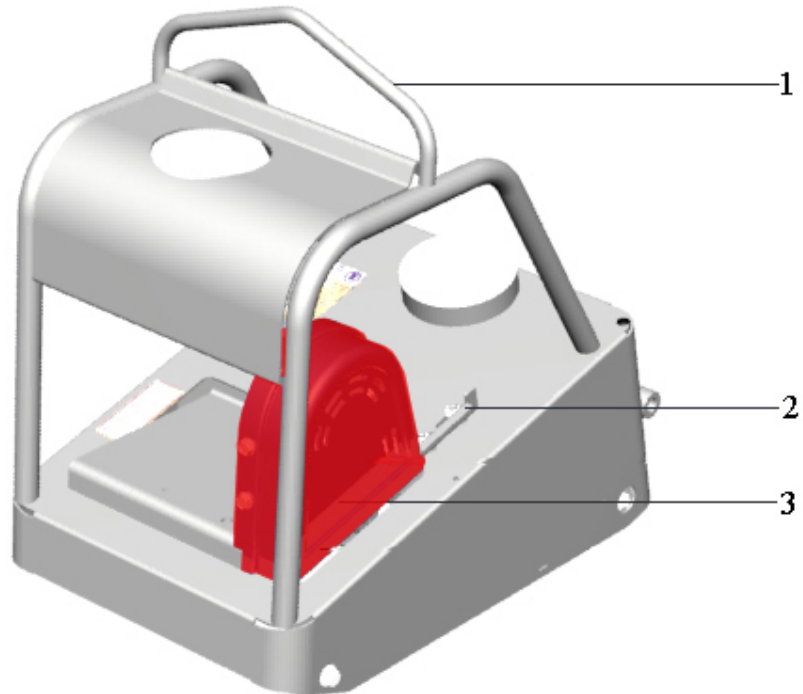

Pos	Label
1	Chassi, parts
2	Belt tensioner, parts
2	Belt tensioner cpl.
3	C Belt guard red, plastic

3.1. CHASSI, PARTS

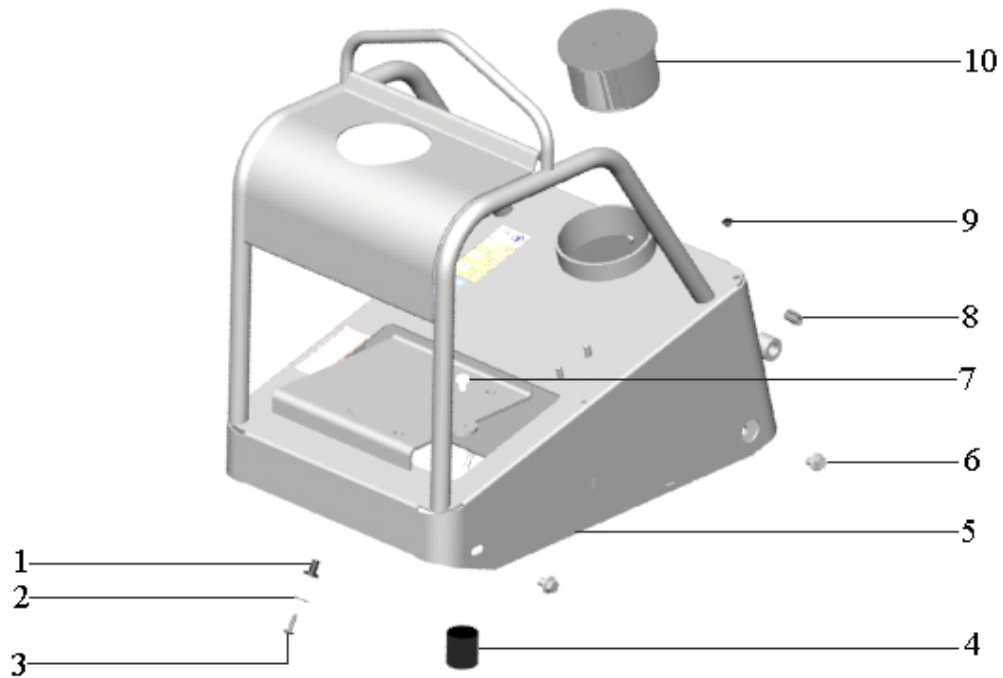

Pos	Part.No	Label	No
1	100468	WELL-NUT	1
2	100346	WASHER / NB 6x19x1fzb	1
3	1001137	BOLT / MRX 5x20 A4	1
4	100745	IMPACT DAMPER	1
5	207083	CHASSI	1
6	1001127	BOLT / M6SF 10x14 FZB	4
7	1001124	SCREW / M6SF 8x12 8.8 FZB	1
8	202061	SPHERICAL BEARING	2
9	101124	PLUG	1
10	101049	CAP-FUEL TANK	1

3.2. BELT TENSIONER, PARTS

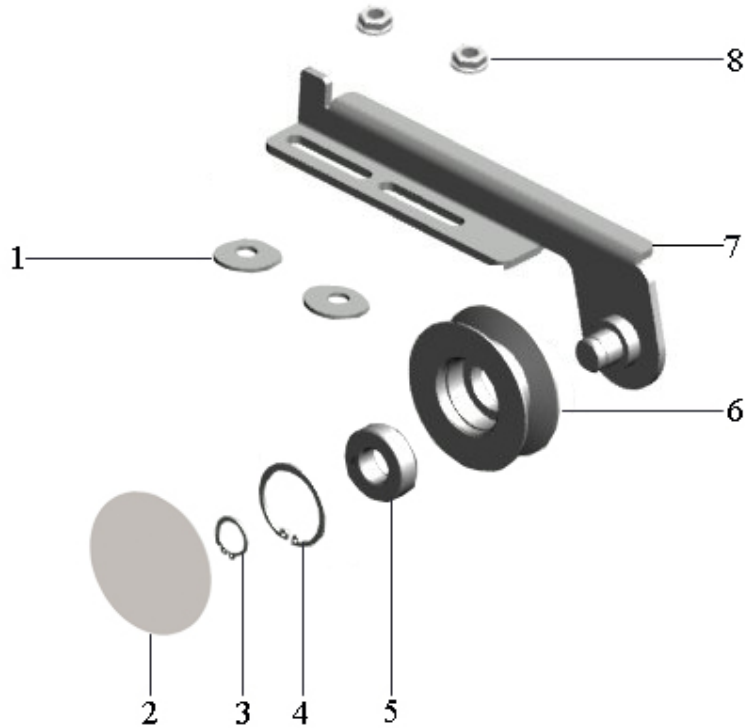

Pos	Part.No	Label	No
1	100309	WASHER / SRKB 9x28x2 HB200 fzb	2
2	204092	SEALING FILM	1
3	100408	CIRCLIP / SGA 15	1
4	100407	CIRCLIP / SGH 32	1
5	100504	BALL BEARING / 6002-02RS1-C3HT51	1
6	202054	WHEEL	1
7	202053	ARM	1
8	100224	NUT / M6MF M8	2

3.2. BELT TENSIONER CPL.

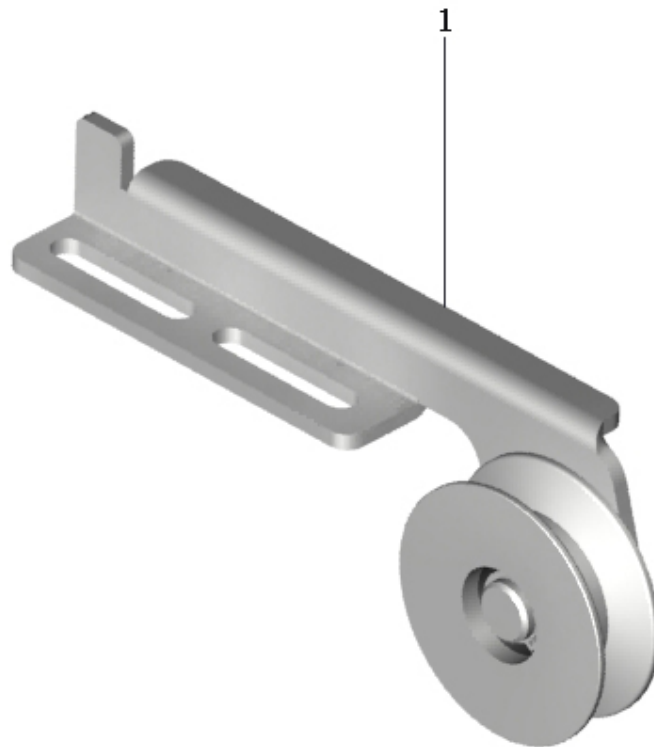

Pos	Part.No	Label	No
1	207099	BELT TENSIONER	1

3.3. C BELT GUARD RED, PLASTIC

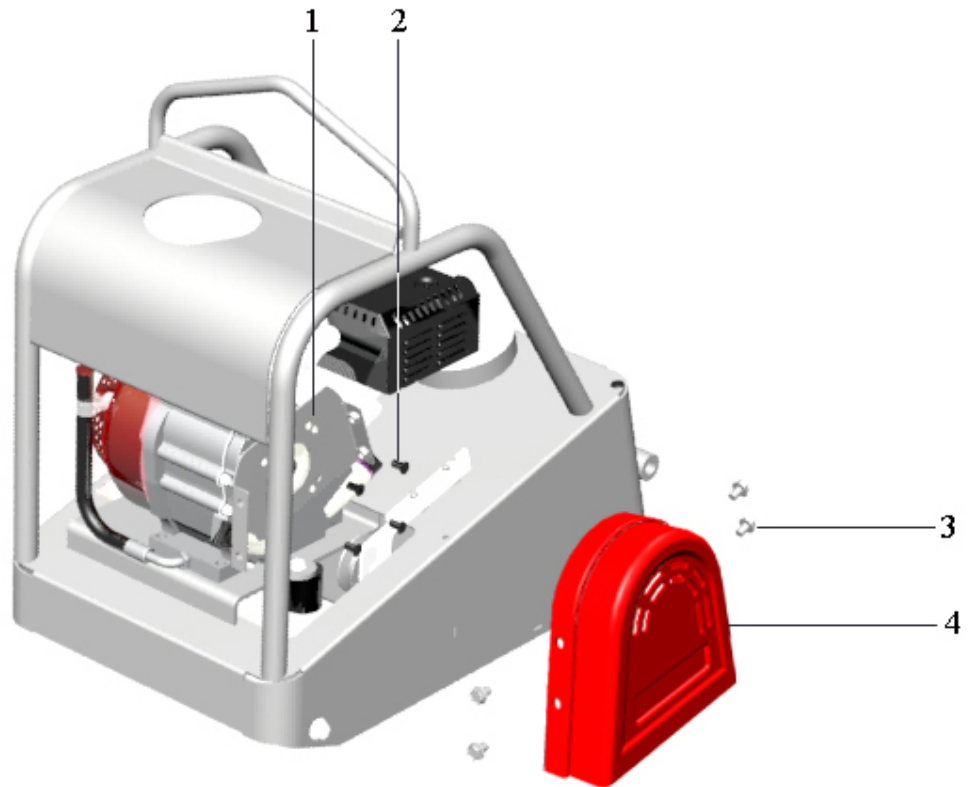

Pos	Part.No	Label	No
1	207060	INNER BELT GUARD	1
2	1001103	SCREW / MELC6S 8x12 10.9	4
3	1001124	SCREW / M6SF 8x12 8.8 FZB	4
4	207091	BELT GUARD	1

4. A VIBRATIONS UNIT, GREASE LUBRICATE

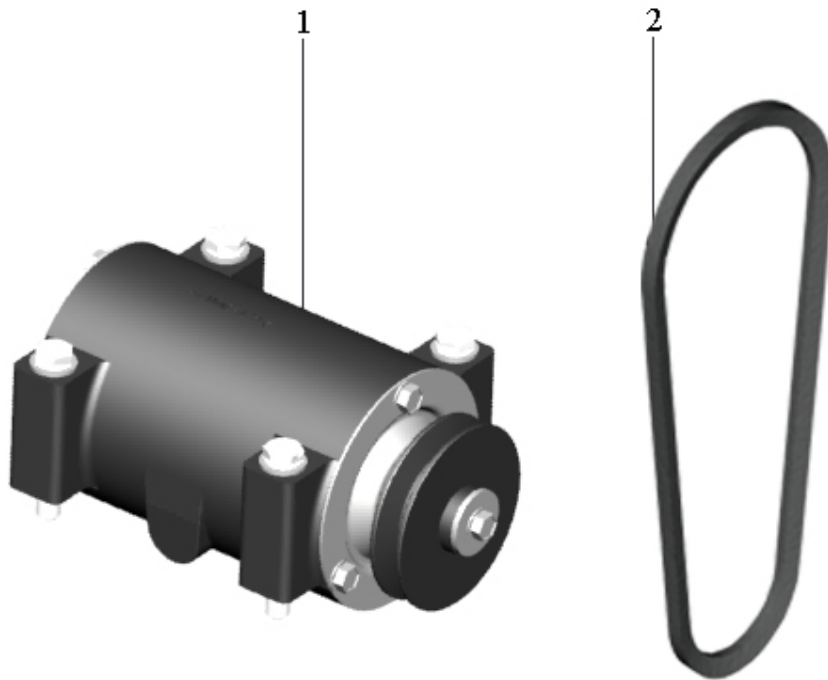

Pos	Label
1	Vibrations unit
1	Vibrations unit, parts
2	V-belt

4.1. VIBRATIONS UNIT

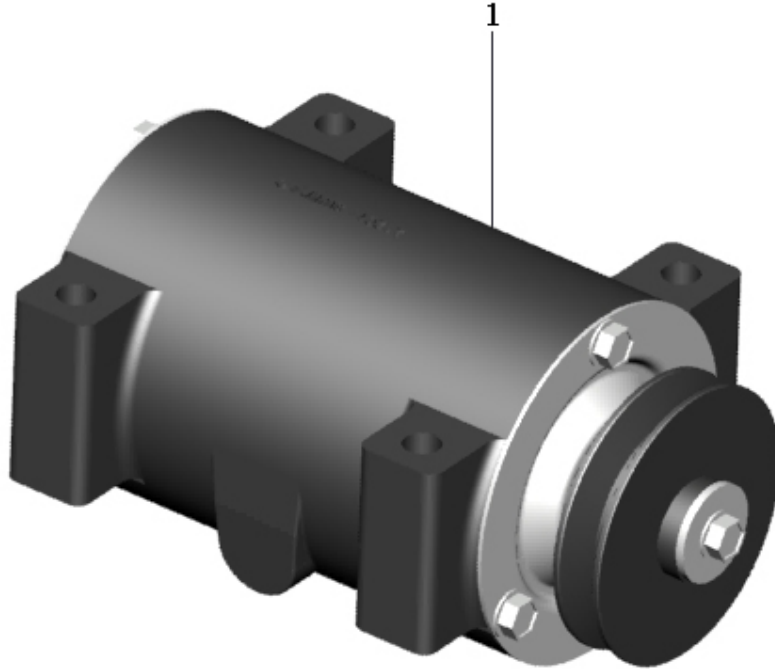

Pos	Part.No	Label	No
1	207081	VIBRATION UNIT	1

4.1. VIBRATIONS UNIT, PARTS

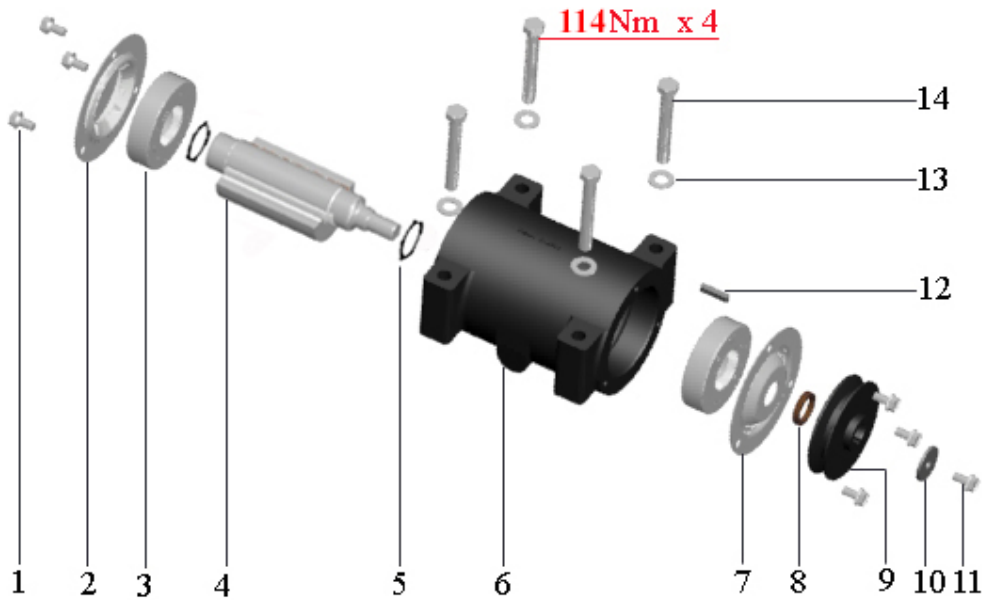

Pos	Part.No	Label	No
1	1001125	BOLT / M6SF 8x16 8.8 FZB	6
2	202129	LOCK	1
3	100528	BALL BEARING / 6308 VV-C3-AHQ	2
4	207080	SHAFT	1
5	100431	CIRCLIP / A40x1,75K	2
6	202128	HOUSING	1
7	202130	LOCK	1
8	100630	V-RING 25 VA	1
9	207008	V-BELT PULLEY	1
10	100306	WASHER / SRKB 9x35x3 HB200 fzb	1
11	1001125	BOLT / M6SF 8x16 8.8 FZB	1
12	100400	FLAT KEY / RK 6x6x30 H9	1
13	100303	WASHER / BRB 13,0x24 HB200 fzb	4
14	1001274	BOLT / M6S 12x90 10.9	4

4.2. V-BELT



Pos	Part.No	Label	No
1	100802	V-BELT / A30	1

4. B VIBRATIONS UNIT, OIL LUBRICATE

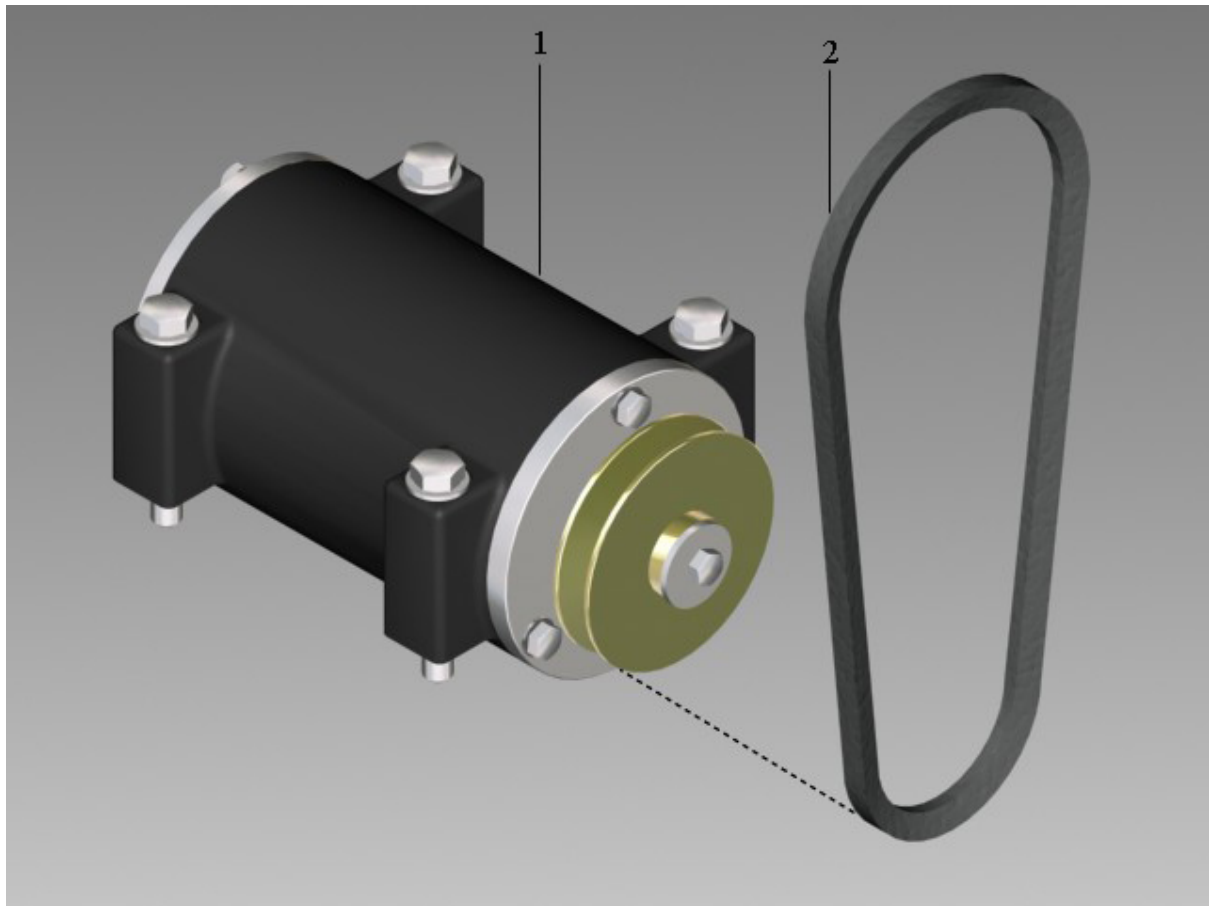

Pos	Label
1	Vibration unit, parts
2	V-belt

4.1. VIBRATION UNIT, PARTS

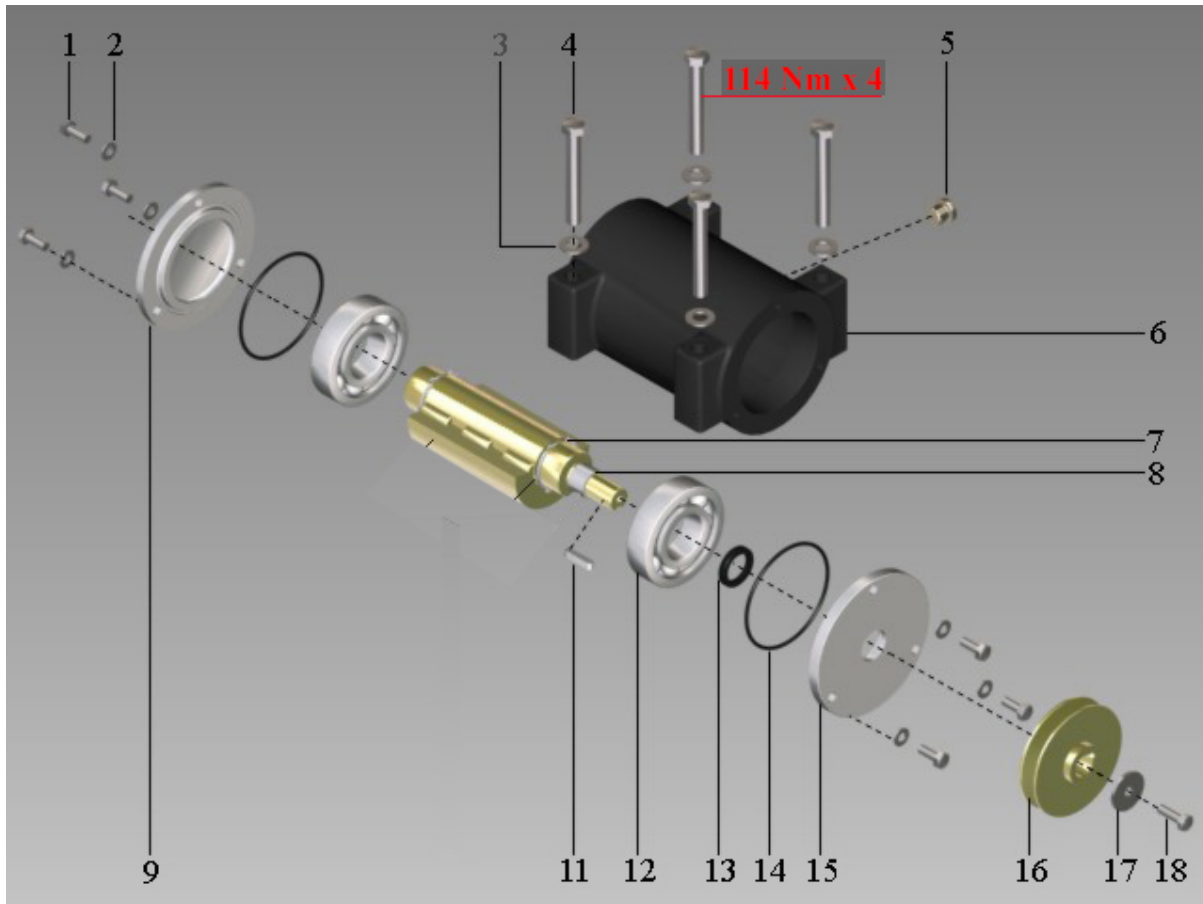

Pos	Part.No	Label	No
1	100101	BOLT / M6S 8x 25 8.8 fzb	6
2	100301	WASHER / BRB 8,4x16 HB200 fzb	6
3	100303	WASHER / BRB 13,0x24 HB200 fzb	4
4	1001274	BOLT / M6S 12x90 10.9	4
5	101000	PLUG R3/8	1
6	202019	HOUSING	1
7	100431	CIRCLIP / A40x1,75K	2
8	100501	INNER RING / LRT 20x25x17	1
9	202016	LOCK	1
11	100400	FLAT KEY / RK 6x6x30 H9	1
12	100500	BALL BEARING / 6308-C3	2
13	100604	RADIAL SEALING / 25x35x6 CCP VITON	1
14	100600	O-RING / 89,5x3 NBR 70	2
15	202018	LOCK	1
16	207008	V-BELT PULLEY	1
17	100306	WASHER / SRKB 9x35x3 HB200 fzb	1
18	100100	BOLT / M6S 8x20 8.8 fzb	1

4.2. V-BELT



Pos	Part.No	Label	No
1	100802	V-BELT / A30	1

5. BASE PLATE WITH BRACKET FOR WHEELS

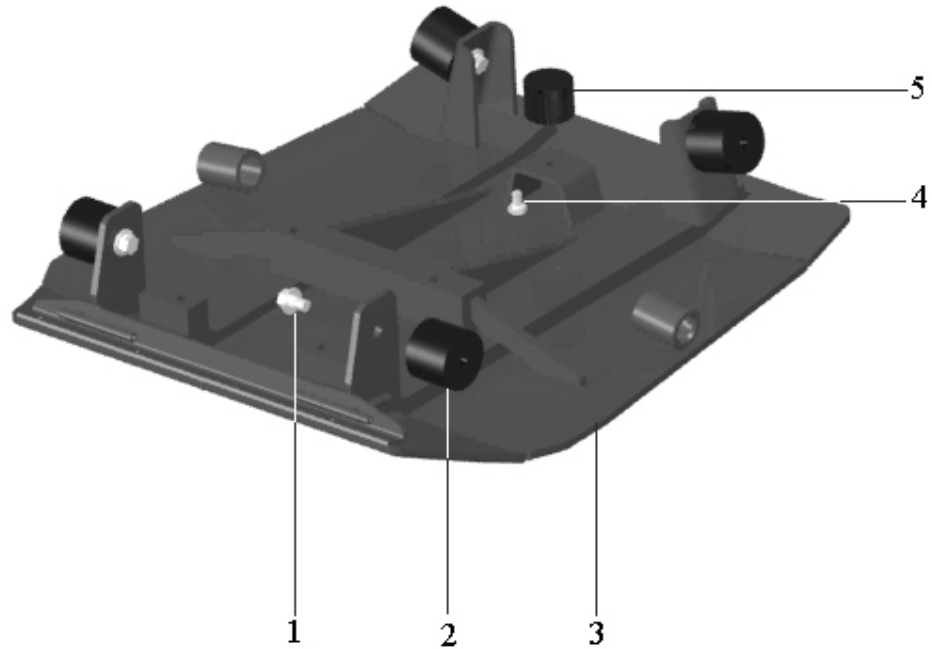

Pos	Part.No	Label	No
1	1001127	BOLT / M6SF 10x14 FZB	4
2	100723	VIBRATION ISOLATOR	4
3	207095	BASE PLATE	1
4	1001124	SCREW / M6SF 8x12 8.8 FZB	1
5	100733	IMPACT DAMPER	1

6. TRANSPORT WHEEL

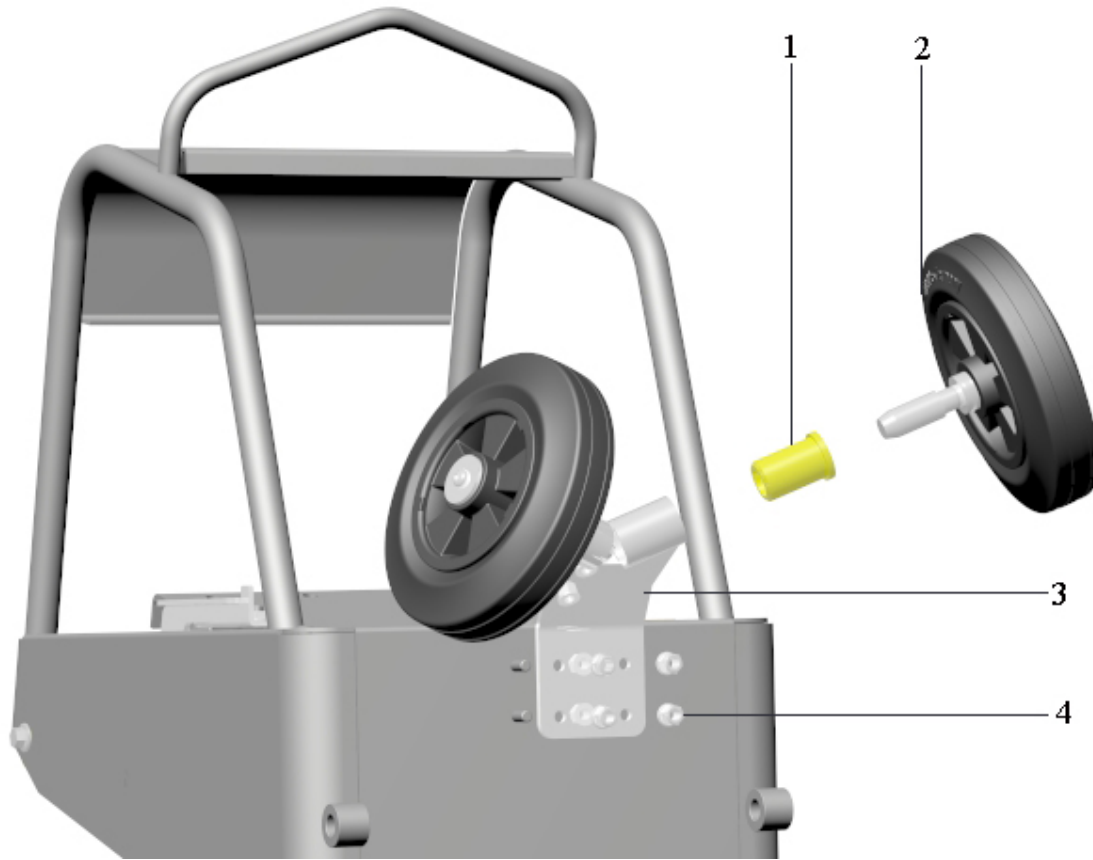

Pos	Part.No	Label	No
1	207076	SLEEVE	2
2	202083	TRANSPORT WHEEL	2
3	207073	BRACKET	1
4	100221	NUT / LOCKING M6MF M8	4

7. HANDLE

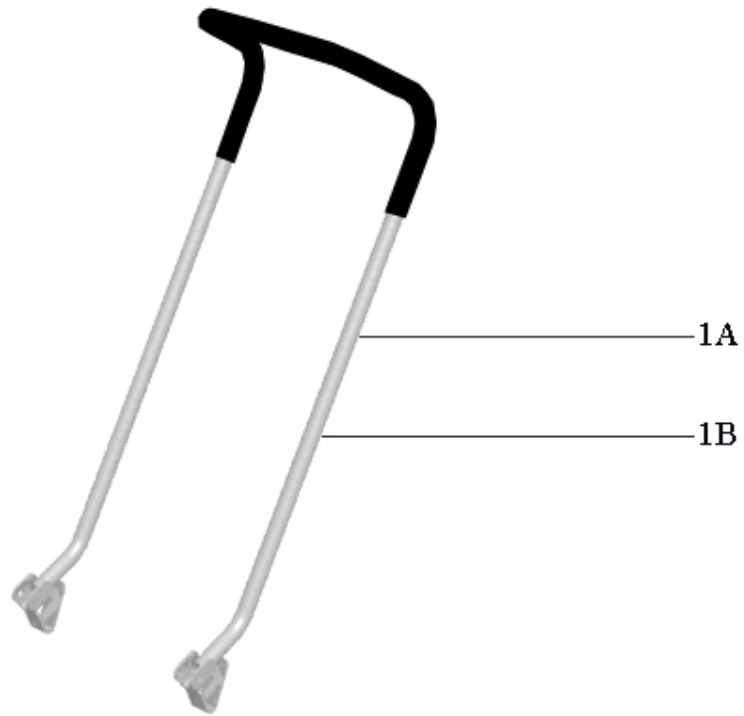

Pos	Label
1	B Low vibrated handle
1	A Handle

7.1. B LOW VIBRATED HANDLE



Pos	Label
1	Handel, cpl
1	Handle, parts

7.1.1. HANDEL, CPL



Pos	Part.No	Label	No
1	207110	LOW VIBRATED HANDLE	1

7.1.1. HANDLE, PARTS

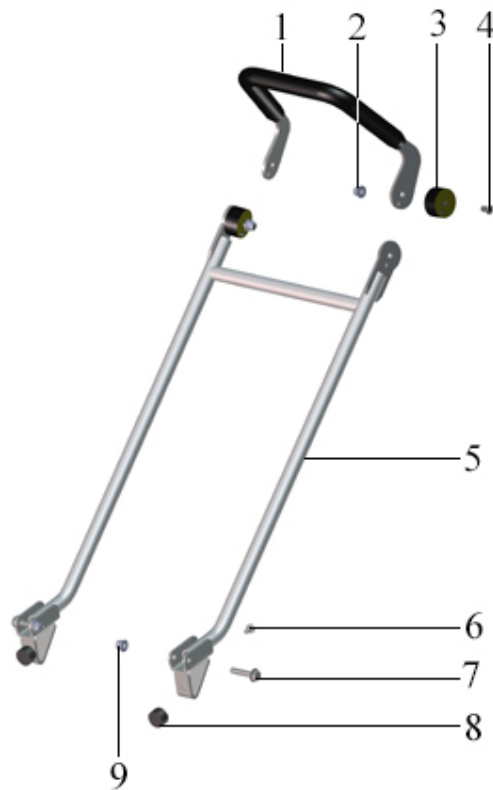

Pos	Part.No	Label	No
1	207100	HANDLE	1
2	100220	NUT / LOCKING M6MF M10	2
3	100753	VIBRATION ISOLATOR	2
4	1001100	BOLT / K6S 10x14 10.9 fzb	2
5	207108	HANDLE LOWER PART	1
6	1001124	SCREW / M6SF 8x12 8.8 FZB	2
7	1001133	BOLT / M6SF 10x50 8.8 FZB	2
8	100708	IMPACT DAMPER	2
9	100220	NUT / LOCKING M6MF M10	2

7.1. A HANDLE

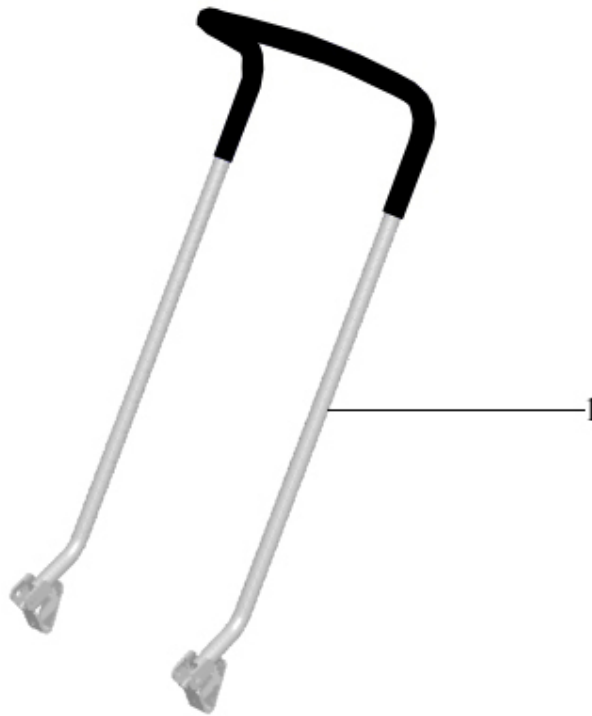

Pos	Label
1	Handel, parts

7.1.1. HANDEL, PARTS

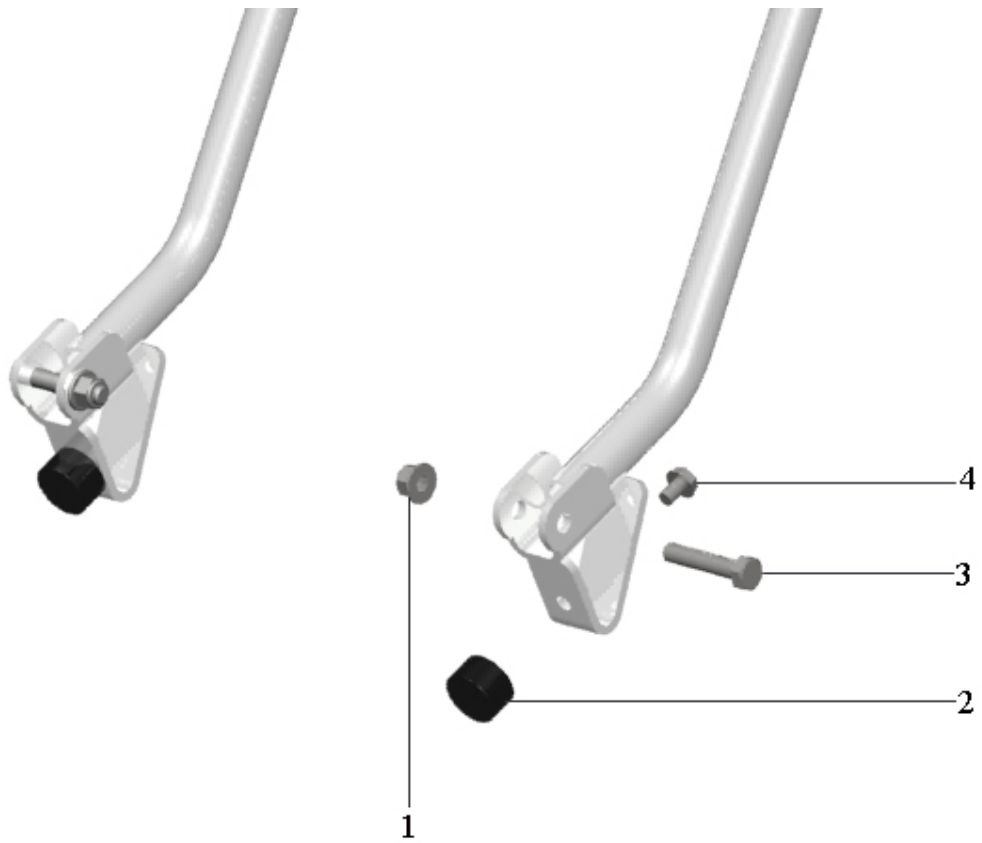

Pos	Part.No	Label	No
1	100220	NUT / LOCKING M6MF M10	2
2	100708	IMPACT DAMPER	2
3	1001133	BOLT / M6SF 10x50 8.8 FZB	2
4	1001124	SCREW / M6SF 8x12 8.8 FZB	2

8. SPRINKLER SYSTEM

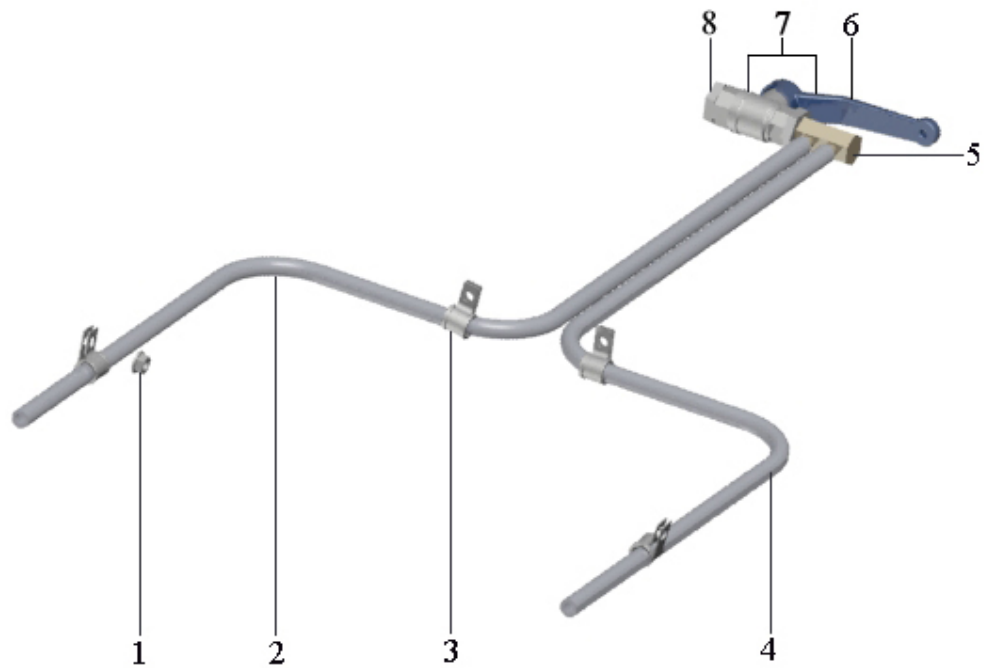

Pos	Part.No	Label	No
1	100223	NUT / M6MF M6	4
2	207085	TUBE	1
3	100405	RUBBER-COVERED CLIP / 13 mm	4
4	207084	TUBE	1
5	207069	DISTRIBUTOR PIPE	1
6	1010045	TURNING HANDLE	1
7	101005	BALL VALVE	1
8	100211	NUT / 3/8	2

9. VULKOLLAN PLATE (ACCESSORIES)

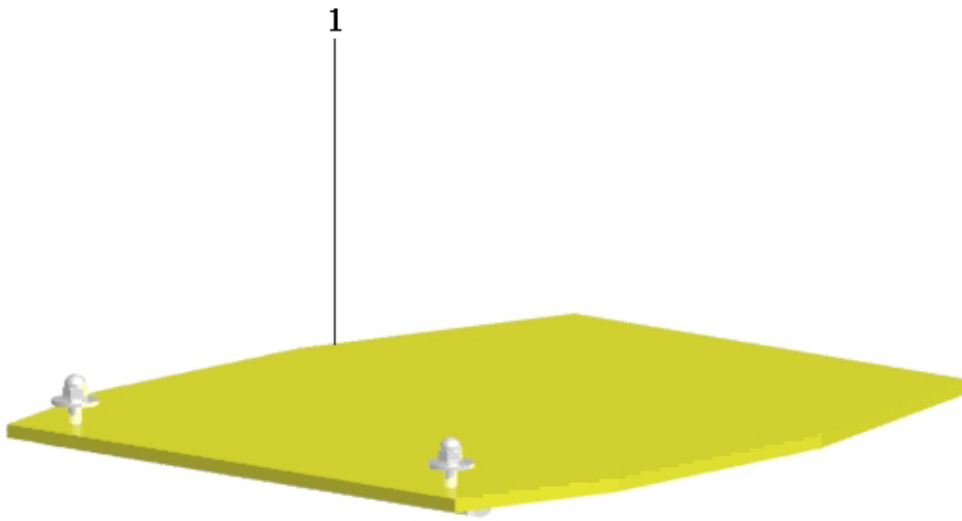

Pos	Label
1	Vulkollan plate, parts
1	Vulkollan plate cpl.

9.1. VULKOLLAN PLATE, PARTS

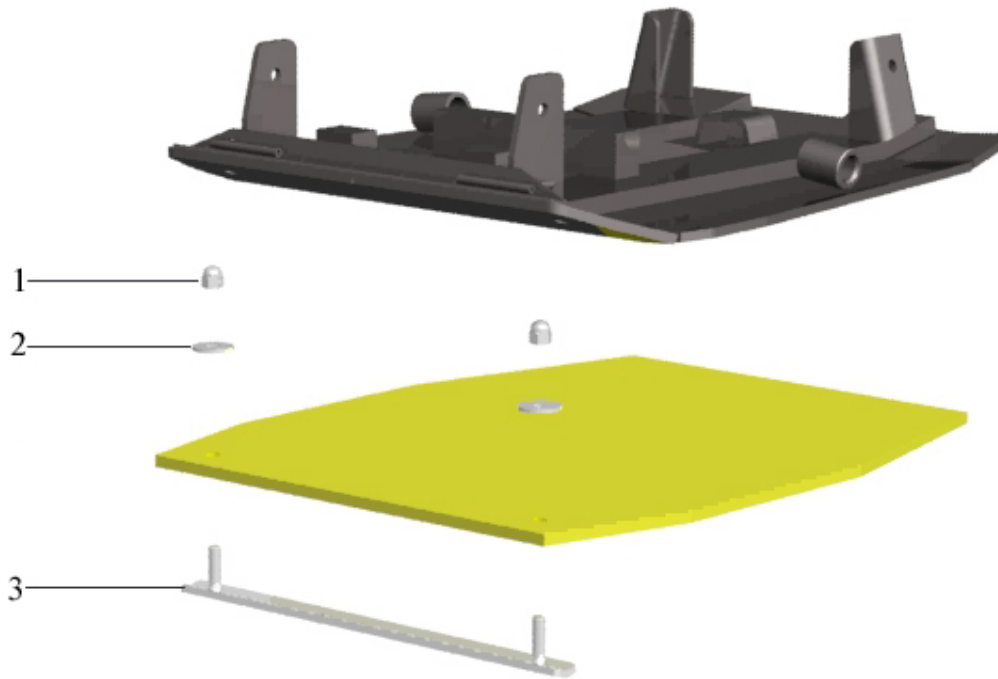

Pos	Part.No	Label	No
1	100220	NUT / LOCKING M6MF M10	2
2	100318	WASHER / SRKB 11x35x3 HB200 fzb	2
3	207049	BRACKET	1

9.1. VULKOLLAN PLATE CPL.

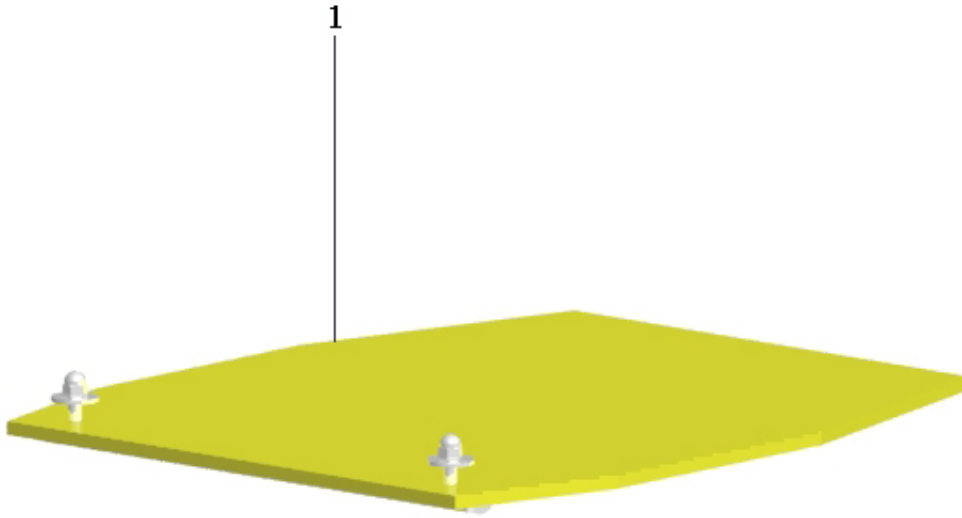

Pos	Part.No	Label	No
1	207035	VULKOLLAN PLATE	1

10. SERVICE KIT



Pos	Label
1	Service kit
2	Service kit

10.1. SERVICE KIT



Pos	Part.No	Label	No
1	102117	SERVICESATS F70A	1
	-	Including parts:	
0	100802	V-BELT / A30	1
0	101209	AIR FILTER	1
0	101278	SPARK-PLUG	1
	-		

10.2. SERVICE KIT



Pos	Part.No	Label	No
1	102115	SERVICEKIT	1
	-	Including parts:	
0	101210	AIR FILTER 70mm HIGH	1
0	101278	SPARK-PLUG	1
0	100802	V-BELT / A30	1
	-		

